



# STANDARDS OF DESIGN AND CONSTRUCTION

March 2023

CITY OF ROCKWALL, TEXAS  
ENGINEERING DEPARTMENT





## TABLE OF CONTENTS

CHAPTER 1   GENERAL REQUIREMENTS .....	1
SECTION 1.01   INTRODUCTION.....	1
SECTION 1.02   STANDARDS OF DESIGN .....	1
SECTION 1.03   STANDARD SPECIFICATIONS FOR CONSTRUCTION .....	1
SECTION 1.04   STANDARD DETAILS .....	1
SECTION 1.05   MATERIALS.....	2
SECTION 1.06   INSPECTION OF CONSTRUCTION BY CITY PERSONNEL .....	2
SECTION 1.07   FRANCHISE AND PUBLIC UTILITIES TO BE UNDERGROUND .....	2
SECTION 1.08   SUBMITTAL TO UTILITY COMPANIES.....	2
SECTION 1.09   REQUIREMENTS OF THE FINAL ENGINEERING DRAWINGS.....	2
SECTION 1.10   ENGINEERING PLAN APPROVAL AND CONSTRUCTION PERMIT RELEASE .....	2
SECTION 1.11   FRANCHISE AND PUBLIC UTILITIES TO BE UNDERGROUND .....	3
SECTION 1.12   FINAL ACCEPTANCE .....	3
SECTION 1.13   CHANGES IN STANDARDS OF DESIGN, CONSTRUCTION, SPECIFICATIONS, AND THIS DOCUMENT .....	4
CHAPTER 2   STREETS.....	5
SECTION 2.01   GENERAL.....	5
SECTION 2.02   STREET ARRANGEMENT .....	5
SECTION 2.03   THOROUGHFARE AND STREET GEOMETRY .....	5
SECTION 2.04   TURN LANES .....	10
SECTION 2.05   MEDIAN OPENINGS, WIDTH, LOCATION AND SPACING .....	10
SECTION 2.06   DRIVEWAY LOCATIONS.....	12
SUBSECTION 2.06.01   DRIVEWAYS ON TXDOT FACILITIES .....	12
SECTION 2.07   BLOCK LENGTHS.....	12
SECTION 2.08   STREET INTERSECTIONS.....	14
SECTION 2.09   RELATION TO ADJOINING STREETS.....	14
SECTION 2.10   DEAD-END STREETS, CUL-DE-SACES, AND COURTS .....	14
SECTION 2.11   ALLEYS AND ALLEY WIDTHS .....	14
SECTION 2.12   STREET GRADES.....	15
SECTION 2.13   PAVEMENT DESIGN.....	16
SUBSECTION 2.13.01   SUBGRADE .....	16
SUBSECTION 2.13.02   STEEL REINFORCED CONCRETE PAVEMENT.....	16
SECTION 2.14   PARKWAYS, GRADES, AND SIDEWALKS .....	18
SUBSECTION 2.14.01   ROADWAY RECONSTRUCTION .....	18
SECTION 2.15   DRIVEWAYS/DRIVE AISLES.....	19
SUBSECTION 2.15.01   RESIDENTIAL .....	19
SUBSECTION 2.15.02   MULTI-FAMILY AND NON-RESIDENTIAL .....	19
SUBSECTION 2.15.03   GRADES .....	19
SECTION 2.16   TRAFFIC INFORMATION AND CONTROL DEVICES.....	22
SUBSECTION 2.16.01   REGULATORY SIGNAGE .....	22
SUBSECTION 2.16.02   STREET NAME BLADES.....	22
SUBSECTION 2.16.03   STANDARD STREET SIGN POLE AND FIXTURES.....	23
SUBSECTION 2.16.04   DECORATIVE SIGN POLES AND FIXTURES .....	23
SUBSECTION 2.16.05   MISCELLANEOUS .....	24
SECTION 2.17   TEMPORARY TRAFFIC CONTROL.....	24
SECTION 2.18   SECTION 1.18   STREET LIGHTING.....	25
SECTION 2.19   BARRIER FREE RAMPS.....	25
SECTION 2.20   OFF-STREET PARKING, LOADING, AND STORAGE AREAS.....	25
SECTION 2.21   TRAFFIC IMPACT ANALYSIS (TIA) AND MITIGATION .....	34
SUBSECTION 2.21.01   PURPOSE .....	34
SUBSECTION 2.21.02   DETERMINATION OF APPLICABILITY.....	35
SUBSECTION 2.21.03   APPLICABILITY OF TIA REQUIREMENTS.....	35
SUBSECTION 2.21.04   REQUIREMENTS FOR TIA UPDATES .....	37
SUBSECTION 2.21.05   FUNDING RESOURCES .....	37
SUBSECTION 2.21.06   RESPONSIBILITY OF TIA PREPARATION AND REVIEW.....	37
SUBSECTION 2.21.07   TIA STANDARDS.....	38
SUBSECTION 2.21.08   TIA METHODOLOGY.....	38
SUBSECTION 2.21.09   TIA REPORT FORMAT.....	40



SUBSECTION 2.21.10   TRAFFIC IMPACT MITIGATION .....	40
SUBSECTION 2.21.11   ADMINISTRATION OF THE TIA .....	41
SUBSECTION 2.21.12   COST OF TIA REVIEW .....	41
<b>CHAPTER 3   STORM DRAINAGE FACILITIES.....</b>	<b>42</b>
SECTION 3.01   INTRODUCTION.....	42
SECTION 3.02   STORM DRAINAGE DESIGN CRITERIA.....	43
SUBSECTION 3.02.01   RATIONAL METHOD .....	43
SUBSECTION 3.02.01.01   RUNOFF COEFFICIENT (C).....	43
SUBSECTION 3.02.01.02   TIME OF CONCENTRATION .....	44
SUBSECTION 3.02.01.03   RAINFALL INTENSITY.....	46
SUBSECTION 3.02.02   UNIT HYDROGRAPH METHOD .....	48
SUBSECTION 3.02.03   DESIGN STORM FREQUENCIES.....	51
SUBSECTION 3.02.04   DRAINAGE CALCULATIONS SUMMARY TABLES .....	51
SUBSECTION 3.02.05   FLOW IN STREETS .....	52
SUBSECTION 3.02.06   FLOW IN ALLEYS .....	52
SUBSECTION 3.02.07   PERMISSIBLE SPREAD OF WATER (PONDING WIDTH).....	53
SUBSECTION 3.02.07.01   GENERAL .....	53
SUBSECTION 3.02.07.02   MAJOR AND MINOR DIVIDED ARTERIALS (P6D & A4D) .....	53
SUBSECTION 3.02.07.03   COLLECTOR STREETS (M4U, M3U, & MINOR COLLECTOR) .....	53
SUBSECTION 3.02.07.04   RESIDENTIAL .....	53
SUBSECTION 3.02.07.05   ALLEYWAYS .....	53
SUBSECTION 3.02.07.06   PARKING LOTS .....	54
SUBSECTION 3.02.08   INLET DESIGN.....	56
SUBSECTION 3.02.08.01   GENERAL .....	56
SUBSECTION 3.02.08.02   TYPES OF INLETS .....	56
SUBSECTION 3.02.08.03   LOCATION .....	57
SUBSECTION 3.02.08.04   CURB INLETS ON-GRADE.....	58
SUBSECTION 3.02.08.05   CURB INLETS AT SAG/LOW POINT .....	64
SUBSECTION 3.02.09   DROP INLETS/'Y' INLET DESIGN.....	66
SUBSECTION 3.02.10   COMBINATION AND GRATE INLET DESIGN .....	66
SUBSECTION 3.02.11   FLOW IN STORM DRAIN CONDUITS AND THEIR APPURTENANCES .....	78
SUBSECTION 3.02.11.01   HYDRAULIC GRADIENT OF CONDUITS.....	78
SUBSECTION 3.02.11.02   MINOR HEAD LOSSES.....	80
SUBSECTION 3.02.11.03   MINIMUM GRADES.....	84
SUBSECTION 3.02.11.04   MINIMUM GRADES.....	84
SUBSECTION 3.02.11.05   DISCHARGE OF STORM DRAIN PIPE .....	84
SUBSECTION 3.02.11.06   MANHOLES.....	84
SUBSECTION 3.02.11.07   LATERAL LINES.....	85
SUBSECTION 3.02.11.08   UNDERDRAINS/FRENCH DRAINS.....	85
SUBSECTION 3.02.11.09   FEDERAL 100-YEAR FLOOD ZONES .....	87
SUBSECTION 3.02.11.10   LOCAL 100-YEAR FLOOD ZONES .....	87
SUBSECTION 3.02.11.11   FLOODPLAIN MARKERS .....	87
SUBSECTION 3.02.11.12   INLET MARKERS.....	87
SUBSECTION 3.02.11.13   DUMPSTERS .....	87
SUBSECTION 3.02.11.14   FUELING STATIONS .....	87
SUBSECTION 3.02.11.15   TESTING .....	87
SUBSECTION 3.02.12   STORM SEWER DESIGN (CLOSED CONDUIT) .....	87
SUBSECTION 3.02.12.01   GENERAL .....	87
SUBSECTION 3.02.13   STORM SEWER DESIGN (OPEN CHANNELS).....	90
SUBSECTION 3.02.13.01   GENERAL .....	90
SUBSECTION 3.02.14   CULVERT DESIGN .....	94
SUBSECTION 3.02.14.01   GENERAL .....	94
SUBSECTION 3.02.15   BRIDGE DESIGN .....	104
SUBSECTION 3.02.16   EROSION HAZARD SETBACK .....	104
SUBSECTION 3.02.16.01   DEFINITION AND PURPOSE .....	104
SUBSECTION 3.02.16.02   DEFINITION AND PURPOSE .....	104
SUBSECTION 3.02.16.03   NON-PERMITTED STRUCTURES .....	106
SUBSECTION 3.02.16.04   MODIFICATIONS .....	106
SECTION 3.03   MINIMUM FREE BOARD REQUIREMENTS.....	107



- SECTION 3.04 | DETENTION ..... 107
  - SUBSECTION 3.04.01 | INTENT ..... 107
  - SUBSECTION 3.04.02 | WHERE IS DETENTION REQUIRED? ..... 107
  - SUBSECTION 3.04.03 | TYPE OF DETENTION FACILITIES ..... 108
  - SUBSECTION 3.04.04 | GEOMETRY, RESTRICTIONS, AND APPURTENANCES ..... 109
  - SUBSECTION 3.04.05 | DETENTION CALCULATIONS ..... 110
    - SUBSECTION 3.04.05.01 | METHODOLOGY ..... 110
    - SUBSECTION 3.04.05.02 | OUTFALL STRUCTURES ..... 112
- SECTION 3.05 | FLOODPLAIN STUDIES, RECLAMATION, AND MODIFICATION ..... 113
- SECTION 3.06 | STORM DRAINAGE MANAGEMENT PLAN ..... 115
  - SUBSECTION 3.06.01 | GENERAL ..... 115
  - SUBSECTION 3.06.02 | SITE DRAINAGE ..... 115
  - SUBSECTION 3.06.03 | SUBDIVISION DEVELOPMENT ..... 116
  - SUBSECTION 3.06.04 | CONSTRUCTION EROSION CONTROLS ..... 116
  - SUBSECTION 3.06.05 | LOT DEVELOPMENT ..... 117
- CHAPTER 4 | VEGETATION ..... 119
  - SECTION 4.01 | GENERAL ..... 119
  - SECTION 4.02 | COVERAGE ..... 119
  - SECTION 4.03 | PLANTING SEASON ..... 119
  - SECTION 4.04 | ADDITIONAL INFORMATION ..... 119
- CHAPTER 5 | WATER AND WASTEWATER SYSTEMS ..... 120
  - SECTION 5.01 | GENERAL REQUIREMENTS ..... 120
    - SUBSECTION 5.01.01 | SYSTEM CAPACITY STUDIES ..... 120
    - SUBSECTION 5.01.02 | CONNECTIONS FOR FUTURE ADJACENT DEVELOPMENTS ..... 120
    - SUBSECTION 5.01.03 | EASEMENTS ..... 121
    - SUBSECTION 5.01.04 | SEPERATION OF WATER AND WASTEWATER LINES ..... 121
    - SUBSECTION 5.01.05 | WATER AND WASTEWATER LINES WITHIN TXDOT RIGHT-OF-WAY ..... 121
    - SUBSECTION 5.01.06 | BORING, JACKING, AND TUNNELING ..... 121
    - SUBSECTION 5.01.07 | CROSSINGS ..... 122
      - SUBSECTION 5.01.07.01 | CITY ROADWAY CROSSINGS ..... 122
      - SUBSECTION 5.01.07.02 | CULVERT CROSSINGS ..... 122
      - SUBSECTION 5.01.07.03 | CREEK CROSSINGS ..... 122
      - SUBSECTION 5.01.07.04 | TXDOT HIGHWAY CROSSING ..... 122
      - SUBSECTION 5.01.07.05 | RAILROAD CROSSINGS ..... 122
  - SECTION 5.02 | WATER SYSTEM ..... 122
    - SUBSECTION 5.02.01 | GENERAL ..... 123
    - SUBSECTION 5.02.02 | CONNECTIONS TO EXISTING DISTRIBUTION SYSTEM ..... 123
    - SUBSECTION 5.02.03 | SIZING OF WATER MAINS ..... 123
    - SUBSECTION 5.02.04 | WATER MAINS LOCATION/ALIGNMENT ..... 125
    - SUBSECTION 5.02.05 | DEPTH OF COVER ..... 125
    - SUBSECTION 5.02.06 | PIPE MATERIAL AND EMBEDMENT ..... 125
    - SUBSECTION 5.02.07 | VALVES ..... 125
      - SUBSECTION 5.02.07.01 | GATE VALVES ..... 126
      - SUBSECTION 5.02.07.02 | BUTTERFLY VALVES ..... 126
      - SUBSECTION 5.02.07.03 | AIR RELEASE, AIR/VACUUM, AND COMBINATION AIR VALVES ..... 126
    - SUBSECTION 5.02.08 | FITTINGS ..... 126
    - SUBSECTION 5.02.09 | CONNECTION TO EXISTING WATER MAINS ..... 126
      - SUBSECTION 5.02.09.01 | TAPPING SLEEVES AND VALVES ..... 126
      - SUBSECTION 5.02.09.02 | CUT-IN CONNECTION ..... 127
    - SUBSECTION 5.02.10 | DEAD-END MAINS ..... 127
    - SUBSECTION 5.02.11 | FIRE HYDRANTS ..... 127
    - SUBSECTION 5.02.12 | WATER SYSTEM CONNECTIONS ..... 128
    - SUBSECTION 5.02.13 | ABANDONMENT OF WATER MAINS ..... 129
  - SECTION 5.03 | WASTEWATER SYSTEM ..... 129
    - SUBSECTION 5.03.01 | GENERAL ..... 129
    - SUBSECTION 5.03.02 | OWNERSHIP AND MAINTENANCE ..... 130
      - SUBSECTION 5.03.02.01 | OWNERSHIP ..... 130
      - SUBSECTION 5.03.02.02 | MAINTENANCE ..... 130



SUBSECTION 5.03.03   CONNECTIONS TO EXISTING WASTEWATER COLLECTION SYSTEM.....	130
SUBSECTION 5.03.04   DESIGN FLOW .....	130
SUBSECTION 5.03.05   SIZING WASTEWATER COLLECTION MAINS.....	131
SUBSECTION 5.03.05.01   GENERAL.....	131
SUBSECTION 5.03.05.02   AVERAGE DAILY FLOW.....	131
SUBSECTION 5.03.05.03   PEAK FLOW FACTOR.....	132
SUBSECTION 5.03.05.04   INFLOW AND INFILTRATION.....	133
SUBSECTION 5.03.06   WASTEWATER MAINS .....	133
SUBSECTION 5.03.06.01   PIPE MATERIAL.....	133
SUBSECTION 5.03.06.02   MINIMUM GRADES.....	133
SUBSECTION 5.03.06.03   CURVED SEWERS.....	134
SUBSECTION 5.03.07   WASTEWATER SERVICE LATERALS.....	134
SUBSECTION 5.03.08   MANHOLES .....	135
SUBSECTION 5.03.08.01   INTERNAL DROP MANHOLES.....	135
SUBSECTION 5.03.08.02   CORROSION PROTECTION .....	135
SUBSECTION 5.03.08.03   WATERTIGHT SEALED MANHOLES.....	135
SUBSECTION 5.03.08.04   INFLOW PREVENTION.....	135
SUBSECTION 5.03.09   CLEANOUTS.....	136
SUBSECTION 5.03.10   TESTING .....	136
SUBSECTION 5.03.11   ABANDONING EXISTING WASTEWATER MAINS AND MANHOLES.....	136
SUBSECTION 5.03.12   CREEK CROSSINGS.....	136
SUBSECTION 5.03.12.01   AERIAL CREEK CROSSINGS.....	136
SUBSECTION 5.03.12.02   INVERTED SIPHON.....	137
SECTION 5.04   WASTEWATER LIFT STATIONS AND FORCE MAINS .....	137
SUBSECTION 5.04.01   GENERAL .....	137
SUBSECTION 5.04.02   DESIGN REPORT AND PLANS .....	137
SUBSECTION 5.04.02.01   REPORT.....	137
SUBSECTION 5.04.02.02   PLANS.....	138
SUBSECTION 5.04.03   SITE SELECTION .....	138
SUBSECTION 5.04.04   SITE REQUIREMENTS.....	138
SUBSECTION 5.04.04.01   ACCESS.....	139
SUBSECTION 5.04.04.02   SECURITY.....	141
SUBSECTION 5.04.04.03   SITE INTERIOR.....	141
SUBSECTION 5.04.05   WET WELL AND VALVE VAULT DESIGN .....	142
SUBSECTION 5.04.05.01   WET WELL DESIGN .....	142
SUBSECTION 5.04.05.02   WET WELL VOLUME.....	143
SUBSECTION 5.04.05.03   VALVE VAULT.....	143
SUBSECTION 5.04.06   PUMPS, LIFT STATION PIPING, AND VALVES.....	143
SUBSECTION 5.04.06.01   PUMPS.....	143
SUBSECTION 5.04.06.02   PUMP CAPACITY.....	144
SUBSECTION 5.04.06.03   LIFT STATION PIPING.....	144
SUBSECTION 5.04.06.04   VALVES.....	144
SUBSECTION 5.04.07   FORCE MAIN.....	145
SUBSECTION 5.04.07.01   GENERAL.....	145
SUBSECTION 5.04.07.02   EMBEDMENT.....	145
SUBSECTION 5.04.08   CONTROL PANEL .....	145
SUBSECTION 5.04.08.01   GENERAL.....	145
SUBSECTION 5.04.08.02   ENCLOSURE.....	146
SUBSECTION 5.04.08.03   INNER DEAD DOOR.....	146
SUBSECTION 5.04.08.04   BACK PLATE.....	146
SUBSECTION 5.04.08.05   POWER DISTRIBUTION.....	146
SUBSECTION 5.04.08.06   CIRCUIT BREAKERS.....	146
SUBSECTION 5.04.08.07   MOTOR STARTERS .....	146
SUBSECTION 5.04.08.08   TRANSFORMERS.....	147
SUBSECTION 5.04.08.09   LIGHTING-TRANSIENT PROTECTION.....	147
SUBSECTION 5.04.08.10   PHASE MONITOR.....	147
SUBSECTION 5.04.08.11   ALARM SYSTEM.....	147
SUBSECTION 5.04.08.12   VAC REGULATOR SYSTEM .....	147
SUBSECTION 5.04.08.13   ANCILLARY EQUIPMENT.....	147
SUBSECTION 5.04.08.14   MISCELLANEOUS .....	148



CHAPTER 6   MISCELLANEOUS REQUIREMENTS .....	149
SECTION 6.01   GRADING .....	149
SECTION 6.02   GRADING, FILL, EXCAVATION, AND EARTHWORK PERMIT .....	149
SECTION 6.03   PRIVATE UTILITY CONSTRUCTION .....	150
SUBSECTION 6.03.01   TRENCH BACKFILL IN CITY RIGHT-OF-WAY .....	150
SUBSECTION 6.03.02   PARKWAY CLEANUP .....	150
SECTION 6.04   ADDITIONAL PERMITS OR APPROVALS .....	150
SECTION 6.05   RETAINING WALLS .....	150
SECTION 6.06   MAINTENANCE BONDS .....	151
SECTION 6.07   CONSTRUCTION .....	151
SUBSECTION 6.07.01   PRELIMINARY SITE PREPERATION.....	151
SUBSECTION 6.07.02   INSPECTION SCHEDULING .....	152
SUBSECTION 6.07.03   VERTICAL ABOVE SLAB CONSTRUCTION PERMIT .....	152
SUBSECTION 6.07.04   DISPOSAL OF EXCESS MATERIALS.....	153
SUBSECTION 6.07.05   DISPOSAL OF EXCESS MATERIALS.....	153
CHAPTER 7   SPECIAL PROVISIONS TO THE NCTCOG'S STANDARD SPECIFICATIONS FOR PUBLIC WORKS CONSTRCTIION STANDARDS .....	154
SECTION 7.01   DIVISION 100. GENERAL PROVISIONS.....	154
SECTION 7.02   DIVISION 200. SITE PROTECTION AND PREPERATION .....	162
SECTION 7.03   DIVISION 300. ROADWAY CONSTRUCTION.....	164
SECTION 7.04   DIVISION 400. ROADWAY MAINTENANCE AND REHABILITATION .....	172
SECTION 7.05   DIVISION 500. UNDERGROUND CONSTRUCTION AND APPURTENANCES .....	173
SECTION 7.06   DIVISION 600. CONDUIT AND APPURTENANCE REHABILITATION .....	191
SECTION 7.07   DIVISION 700. STRUCTURES.....	192
SECTION 7.08   DIVISION 800. MISCELLANEOUS CONSTRUCTION AND MATERIALS.....	193
CHAPTER 8   SPECIAL PROVISIONS TO THE NCTCOG'S STANDARD DRAWINGS FOR PUBLIC WORKS CONSTRUCTION STANDARDS .....	198
SECTION 8.01   DIVISION 1000. EROSION AND SEDIMENT CONTROL .....	198
SECTION 8.02   DIVISION 2000. PAVEMENT SYSTEMS .....	205
SECTION 8.03   DIVISION 3000. GENERAL UNDERGROUND CONDUIT .....	250
SECTION 8.04   DIVISION 4000. WATER DISTRIBUTION .....	261
SECTION 8.05   DIVISION 5000. WASTEWATER COLLECTION.....	272
SECTION 8.06   DIVISION 6000. STORM WATER DRAINAGE.....	291
SECTION 8.07   DIVISION 7000. ROCKWALL MISCELLANEOUS DETAILS.....	317
APPENDIX A   ENGINEERING PLAN REVIEW CHECKLIST .....	320
APPENDIX B   APPROVED WATER MATERIALS LIST .....	331
APPENDIX C   APPROVED WASTEWATER MATERIALS LIST .....	335
APPENDIX D   EXAMPLE CHECKLIST FOR FINAL ACCEPTANCE (RESIDENTIAL AND COMMERCIAL).....	338



## LIST OF FIGURES

FIGURE 2.1: TYPICAL THOROUGHFARE CROSS SECTIONS .....	7
FIGURE 2.2: TYPICAL THOROUGHFARE CROSS SECTIONS .....	8
FIGURE 2.3: TYPICAL THOROUGHFARE CROSS SECTIONS .....	9
FIGURE 2.4: MINIMUM DRIVEWAY SPACING AND CORNER CLEARANCE .....	13
FIGURE 2.5: DRIVEWAY PROFILES ON AN UPGRADE .....	21
FIGURE 2.6: DRIVEWAY PROFILES ON A DOWNGRADE .....	21
FIGURE 2.7: 90° PARKING (DOUBLE ROW) .....	27
FIGURE 2.8: 90° PARKING (SINGLE ROW) .....	28
FIGURE 2.9: 60° PARKING (DOUBLE ROW) .....	29
FIGURE 2.10: 60° PARKING (SINGLE ROW) .....	30
FIGURE 2.11: 45° PARKING (DOUBLE ROW) .....	31
FIGURE 2.12: 45° PARKING (SINGLE ROW) .....	32
FIGURE 2.13: HANDICAP SPACE PARKING .....	33
FIGURE 3.1: IDF CURVE .....	47
FIGURE 3.2: THOROUGHFARE GUTTER CAPACITY BASED ON MAXIMUM PERMISSIBLE PONDING WIDTH .....	55
FIGURE 3.3: GUTTER CROSS-SECTION DIAGRAM OF CURB INLETS ON GRADE .....	59
FIGURE 3.4: CURB INLET CAPACITY ON-GRADE PRINCIPAL AND MINOR ARTERIAL (P6D & A4D) .....	61
FIGURE 3.5: CURB INLET CAPACITY ON-GRADE MAJOR COLLECTOR (M4U) .....	62
FIGURE 3.6: CURB INLET CAPACITY ON-GRADE COLLECTION TWO (2) LANE WITH CONTINUOUS LEFT (M3U) .....	62
FIGURE 3.7: CURB INLET CAPACITY ON-GRADE MINOR COLLECTOR .....	63
FIGURE 3.8: CURB INLET CAPACITY ON-GRADE LOCAL RESIDENTIAL STREET .....	63
FIGURE 3.9: CURB INLET CAPACITY ON-GRADE ALLEY .....	64
FIGURE 3.10: STANDARD CURB INLET CAPACITY SAG/LOW .....	65
FIGURE 3.11: RECESSED CURB INLET CAPACITY SAG/LOW POINT .....	65
FIGURE 3.12: DROP/'Y' INLET CAPACITY .....	66
FIGURE 3.13: TWO (2) GRATE COMBINATION INLET CAPACITY CURVES ON GRADE .....	70
FIGURE 3.14: FOUR (4) GRATE COMBINATION INLET CAPACITY CURVES ON GRADE .....	71
FIGURE 3.15: THREE (3) GRATE INLET AND THREE (3) GRATE COMBINATION INLET CAPACITY CURVES ON GRADE .....	72
FIGURE 3.16: TWO (2) GRATE INLET CAPACITY CURVES ON GRADE .....	73
FIGURE 3.17: FOUR (4) GRATE INLET CAPACITY CURVES ON GRADE .....	74
FIGURE 3.18: SIX (6) GRATE INLET CAPACITY CURVES ON GRADE .....	75
FIGURE 3.19: GRATE INLET CAPACITY CURVES AT LOW POINT .....	76
FIGURE 3.20: COMBINATION INLET CAPACITY CURVES AT LOW POINT .....	77
FIGURE 3.21: CAPACITY OF CIRCULAR PIPES FLOWING FULL .....	79
FIGURE 3.22: LAKE RAY HUBBARD TYPICAL STORM SEWER INSTALLATION .....	86
FIGURE 3.23: HEADWATER DEPTH FOR CONCRETE BOX CULVERT WITH INLET CONTROL .....	98
FIGURE 3.24: HEADWATER DEPTH FOR CONCRETE PIPE CULVERT WITH INLET CONTROL .....	99
FIGURE 3.25: HEAD FOR CONCRETE BOX CULVERT FLOWING FULL .....	100
FIGURE 3.26: HEAD FOR CONCRETE PIPE CULVERTS FLOWING FULL .....	101
FIGURE 3.27: CRITICAL DEPTH OF FLOW FOR RECTANGULAR CONDUITS .....	102
FIGURE 3.28: CRITICAL DEPTH OF FLOW FOR CIRCULAR CONDUITS .....	103
FIGURE 3.29: EROSION HAZARD SETBACKS AND DRAINAGE EASEMENTS .....	105
FIGURE 5.1: TYPICAL LIFT STATION SITE LAYOUT .....	140





## LIST OF TABLES

TABLE 2.1: THOROUGHFARE GEOMETRIC DESIGN STANDARDS .....	6
TABLE 2.2: MEDIAN DESIGN STANDARDS .....	11
TABLE 2.3: CREST VERTICAL CURVES .....	15
TABLE 2.4: MINIMUM LENGTH OF VERTICAL CURVE IN FEET (ROUNDED) .....	15
TABLE 2.5: SAG VERTICAL CURVES .....	15
TABLE 2.6: MINIMUM LENGTH OF VERTICAL CURVE IN FEET (ROUNDED) .....	16
TABLE 2.7: STEEL REINFORCED CONCRETE PAVEMENT DESIGN .....	16
TABLE 2.8: DRIVEWAY GRADES AND GRADE CHANGE .....	19
TABLE 2.9: VERTICAL CURVE LENGTHS FOR DRIVEWAYS .....	20
TABLE 2.10: CRITERIA FOR DETERMINING TIA STUDY REQUIREMENTS .....	36
TABLE 2.11: CRITERIA FOR DETERMINING TIA UPDATE REQUIREMENTS .....	37
TABLE 3.1: DRAINAGE EASEMENTS (MINIMUM WIDTHS) .....	42
TABLE 3.2: RUNOFF COEFFICIENT FOR TYPES OF LAND USE .....	44
TABLE 3.3: MINIMUM INLET TIME OF CONCENTRATION .....	44
TABLE 3.4: SHEET FLOW 'N' VALUES .....	45
TABLE 3.5: PRECIPITATION FREQUENCY ESTIMATES IN INCHES FOR ROCKWALL, TEXAS .....	50
TABLE 3.6: NRCS RUNOFF CURVE NUMBERS (AMC <sub>II</sub> ) FOR VARIOUS LAND USE CLASSIFICATIONS .....	51
TABLE 3.7: STORM DRAIN INLETS .....	57
TABLE 3.8: ENTRANCE LOSS COEFFICIENTS .....	81
TABLE 3.9: VELOCITY HEAD LOSS COEFFICIENTS FOR CLOSED CONDUITS .....	83
TABLE 3.10: MINIMUM GRADES FOR STORM DRAIN PIPELINES .....	84
TABLE 3.11: MAXIMUM VELOCITIES IN CLOSED CONDUITS .....	84
TABLE 3.12: ROUGHNESS COEFFICIENTS FOR OPEN CHANNELS AND MAXIMUM VELOCITY .....	93
TABLE 3.13: CULVERT DISCHARGE VELOCITIES .....	94
TABLE 3.14: MINIMUM FREE BOARD REQUIREMENTS .....	107
TABLE 3.15: STORM RAINFALL INTENSITY (INCHES/HOUR) .....	111
TABLE 5.1: MINIMUM WIDTH FOR WATER AND WASTEWATER LINE EASEMENTS .....	121
TABLE 5.2: WATER DEMAND RATES .....	124
TABLE 5.3: STANDARD WATER MAIN SIZES .....	125
TABLE 5.4: DEPTH OF COVER TO TOP OF PIPE .....	125
TABLE 5.5: STANDARD WASTEWATER COLLECTION SYSTEM PIPE SIZES .....	131
TABLE 5.6: WASTEWATER PER CAPITA AND USAGE RATES .....	132
TABLE 5.7: PIPE MATERIALS FOR WASTEWATER GRAVITY MAINS .....	133
TABLE 5.8: MINIMUM GRADES FOR WASTEWATER PIPELINES .....	134
TABLE 5.9: MINIMUM MANHOLE SIZES .....	135
TABLE 5.10: MINIMUM PUMP CYCLE TIME .....	143
TABLE 7.1: REVISIONS TO NCTCOG'S DIVISION 100 GENERAL PROVISIONS .....	154
TABLE 7.2: REVISIONS TO NCTCOG'S DIVISION 200 SITE PROTECTION AND PREPARATION .....	162
TABLE 7.3: REVISIONS TO NCTCOG'S DIVISION 300 ROADWAY CONSTRUCTION .....	164
TABLE 7.4: REVISIONS TO NCTCOG'S DIVISION 400 ROADWAY MAINTENANCE AND REHABILITATION .....	172
TABLE 7.5: REVISIONS TO NCTCOG'S DIVISION 500 UNDERGROUND CONSTRUCTION AND APPURTENANCES .....	173
TABLE 7.6: REVISIONS TO NCTCOG'S DIVISION 600 CONDUIT AND APPURTENANCE REHABILITATION .....	191
TABLE 7.7: REVISIONS TO NCTCOG'S DIVISION 700 STRUCTURES .....	192
TABLE 7.8: REVISIONS TO NCTCOG'S DIVISION 800 MISCELLANEOUS CONSTRUCTION AND MATERIALS .....	193
TABLE 8.1: DIVISION 1000 EROSION AND SEDIMENT CONTROL .....	198
TABLE 8.2: REVISIONS TO NCTCOG'S DIVISION 2000 PAVEMENT SYSTEMS .....	205
TABLE 8.3: REVISIONS TO NCTCOG'S DIVISION 3000 GENERAL UNDERGROUND CONDUIT .....	250
TABLE 8.4: REVISIONS TO NCTCOG'S DIVISION 4000 WATER DISTRIBUTION .....	261
TABLE 8.5: REVISIONS TO NCTCOG'S DIVISION 5000 WASTEWATER COLLECTION .....	272
TABLE 8.6: REVISIONS TO NCTCOG'S DIVISION 6000 STORM WATER DRAINAGE .....	291
TABLE 8.7: DIVISION 7000. ROCKWALL MISCELLANEOUS DETAILS .....	317
TABLE B.1: SERVICE SADDLES (FOR PVC, DI OR CI) .....	333
TABLE B.2: CORPORATION VALVE (STOPS) .....	333
TABLE B.3: ANGLE METER VALVES (STOPS) .....	333
TABLE B.4: FIRE HYDRANT PAINT .....	334
TABLE B.5: METER BOXES .....	334



LIST OF FORMS

FORM 3.1: DRAINAGE AREA CALCULATIONS TABLE..... 52  
FORM 3.2: INLET DESIGN CALCULATIONS TABLE ..... 67  
FORM 3.3: STORM SEWER CALCULATIONS TABLE ..... 88  
FORM 3.4: OPEN CHANNEL CALCULATIONS TABLE ..... 91  
FORM 3.5: CULVERT DESIGN CALCULATIONS TABLE..... 95



## LIST OF EQUATIONS

EQUATION 3.1: RATIONAL METHOD .....	43
EQUATION 3.2: TRAVEL TIME IN MINUTES FOR SHEET FLOW.....	45
EQUATION 3.3: SHALLOW CONCENTRATED FLOW TRAVEL TIME .....	45
EQUATION 3.4: CHANNEL FLOW TRAVEL TIME .....	45
EQUATION 3.5: NRCS CONVERSION EQUATION.....	48
EQUATION 3.6: MAXIMUM SHEET FLOW LENGTH.....	49
EQUATION 3.7: STORM WATER FLOW IN STREETS .....	52
EQUATION 3.8: MANNING'S EQUATION.....	53
EQUATION 3.9: PONDING WIDTH "T" FOR STRAIGHT CROWNED STREETS .....	53
EQUATION 3.10: SIZING OF CURB INLETS ON GRADE .....	59
EQUATION 3.11: SIZING OF CURB INLETS ON GRADE .....	59
EQUATION 3.12: SIZING OF CURB INLETS ON GRADE .....	59
EQUATION 3.13: SIZING OF CURB INLETS ON GRADE .....	59
EQUATION 3.14: SIZING OF CURB INLETS ON GRADE .....	60
EQUATION 3.15: SIZING OF CURB INLETS ON GRADE .....	60
EQUATION 3.16: SIZING OF CURB INLETS ON GRADE .....	60
EQUATION 3.17: SIZING OF CURB INLETS ON GRADE .....	60
EQUATION 3.18: SIZING OF CURB INLETS ON GRADE .....	61
EQUATION 3.19: CAPACITY OF CURB INLETS AT SAG/LOW POINT .....	64
EQUATION 3.20: REQUIRED CURB INLET LENGTH AT A SAG POINT .....	64
EQUATION 3.21: CAPACITY OF DROP INLETS.....	66
EQUATION 3.22: LENGTH OF DROP INLET .....	66
EQUATION 3.23: SIZE OF CONDUIT.....	78
EQUATION 3.24: ENTRANCE LOSSES TO A CLOSED STORM SEWER SYSTEM FROM AN OPEN CHANNEL OR LAKE .....	80
EQUATION 3.25: INLET LOSSES .....	81
EQUATION 3.26: EXPANSION LOSSES.....	81
EQUATION 3.27: MANHOLE AND BEND LOSSES .....	82
EQUATION 3.28: JUNCTION LOSSES .....	82
EQUATION 5.1: WET WELL VOLUME .....	143





## CHAPTER 1 | GENERAL REQUIREMENTS

### SECTION 1.01 | INTRODUCTION

The *Standards of Design and Construction* are generated to implement the provisions of [CHAPTER 38, SUBDIVISIONS, OF THE MUNICIPAL CODE OF ORDINANCES](#) [the *Subdivision Ordinance*] and to provide for the orderly, safe, healthy and uniform development of the area within the corporate city limits and within the surrounding City's Extraterritorial Jurisdiction (ETJ).

The [5TH EDITION OF THE NORTH CENTRAL TEXAS COUNCIL OF GOVERNMENTS \(NCTCOG\) STANDARD SPECIFICATIONS FOR PUBLIC WORKS CONSTRUCTION](#) dated November 2017 as modified by the City of Rockwall's Special Provisions are supplemental and are made a part of these *Standards of Design and Construction*. These documents are to be considered as the minimum requirements of engineering design. The adherence to the requirements of these documents and/or the approval by the City of Rockwall and its agents in no way relieves the developer or their engineer of the responsibility for adequacy of design, which may require more stringent standards than these, the completeness of plans and specifications or the suitability of the completed facilities. In unusual circumstances, the City of Rockwall may determine that designs other than those of the *Standards of Design and Construction* are necessary and will inform the developer of such requirements before final engineering review.

The developer and/or their representative shall obtain authorization from the City of Rockwall, in writing, for any deviations from the requirements set forth in the standards of design, standard specifications for construction or standard details.

### SECTION 1.02 | STANDARDS OF DESIGN

The *Standards of Design and Construction*, as adopted by the City of Rockwall, are set forth herein. These standards shall be considered as the minimum requirements, and it shall be the responsibility of the developer and design engineer to determine if more stringent requirements are necessary for a particular development. If any standard and/or detail in this document conflicts with North Central Texas Council of Governments (NCTCOG) or additional City document, the more stringent requirement will apply. It is not intended that the *Standards of Design and Construction* cover all aspects of a development. For those elements omitted, the developer and design engineer will be expected to provide designs and facilities in accordance with good engineering practice and to cause the facilities to be constructed utilizing first class workmanship and materials. The City Engineer reserves the right to request additional information not covered within these *Standards of Design and Construction* to be included in the design plans by the developer/design engineer in order to validate the intent, safety, constructability, readability and competency of the design plans. Unless otherwise specified in this document, any variances to the standards contained within the Engineering Department's *Standards of Design and Construction Manual* shall be subject to the processes and procedures stipulated for variances as defined in [SUBSECTION 09, EXCEPTIONS AND VARIANCES, OF ARTICLE 11, DEVELOPMENT APPLICATIONS AND REVIEW PROCEDURES, OF THE UNIFIED DEVELOPMENT CODE \(UDC\)](#).

The Developer/Engineer must ensure that all design and construction is in accordance with all Federal, State, and local regulations and must provide certification on final plans. A copy of all determinations, permits, and approvals received from Federal, State, and local agencies must be provided to the Engineering Department prior to approval.

The engineering design and plans submitted to the Engineering Department by the developer/design engineer shall be in conformance with the adopted *Standards of Design and Construction Manual* that is in affect when the first submittal is received by the Engineering Department. If subsequent submittals have not been received within one (1) year of the previous submittal, any subsequent submittals must conform to the current adopted *Standards of Design and Construction Manual*. Approved construction plans will expire within one (1) year of the approval date if construction has not begun or ceased to continue, and must be reviewed and revised to meet the current adopted *Standards of Design and Construction*.

### SECTION 1.03 | STANDARD SPECIFICATIONS FOR CONSTRUCTION

The City of Rockwall's *Special Provisions* to the North Central Texas Council of Governments (NCTCOG) *Standard Specifications for Public Works Construction, 5th Edition (November 2017)*, as adopted by the City of Rockwall is referenced in this document. The *Standard Specifications* for construction set forth the minimum requirements for materials and workmanship for streets, parking lots, sidewalks, drainage, water and wastewater systems.

### SECTION 1.04 | STANDARD DETAILS

In an effort to have uniformity and to facilitate maintenance, the City has adopted the North Central Texas Council of Governments (NCTCOG) *Standard Drawings* as modified by the City of Rockwall's *Special Provisions* for certain facilities such as manholes, street



sections, sidewalks, water, wastewater, storm water, curb inlets, barrier free ramps, etc. The City of Rockwall's *Special Provisions* can be obtained from the City of Rockwall's Engineering Department. The NCTCOG *Standard Specifications* can be obtained from NCTCOG's Regional Information Center at (817) 695-9140.

### SECTION 1.05 | MATERIALS

All materials to be permanently installed for use on projects in the City of Rockwall shall be produced in the United States of America. Alternate products must be approved in writing by the City Engineer prior to installation. "Domestically produced in the United States of America" means all manufacturing processes must occur in the United States of America in one of the 50 States, the District of Columbia, Puerto Rico or in the territories and possessions of the United States. The *Approved Materials List* can be found in [APPENDIX 'B'](#) and [APPENDIX 'C'](#) of this manual.

### SECTION 1.06 | INSPECTION OF CONSTRUCTION BY CITY PERSONNEL

Inspection of construction and verification of compliance to the plans and specifications shall be conducted by the City of Rockwall's staff under the direction of the City Engineer. The facilities included in this inspection requirement are streets, sidewalks, parking lots, fire lanes, alleys, storm drainage facilities, water distribution systems, wastewater collection system, erosion control, etc. The developer shall advise all of his/her construction contractors of this requirement. No development will be accepted by the City of Rockwall until all construction has been approved by the City's staff. The developer shall be responsible for any additional expenses to the City of Rockwall -- *at a rate established by the City* -- if the inspection is done after the City's normal business hours. The date of acceptance will be when all items have been accepted by the City. 20-months from the date of acceptance of a project, the City will determine any failures or defects and all repairs will be made by the contractor. The accepted method of inspection for underground utilities shall be video, and the City will require a copy of such inspection. The developer and/or contractor shall be responsible for the cost of the video inspection.

### SECTION 1.07 | FRANCHISE AND PUBLIC UTILITIES TO BE UNDERGROUND

All franchise and public utilities within a development shall be placed underground. Utilities are defined for this purpose of this section as water pipelines, wastewater pipelines, storm water pipelines, natural gas pipelines, telephone wires, cable TV wires and electric wires. In case of special or unique circumstances, the City Council of the City of Rockwall may grant variances or exceptions to this requirement. Any request for variance or exception should be submitted in writing to the City of Rockwall Planning and Zoning Department, and include a written statement providing justification for the requested variance or exception. The granting of a variance or exception by the City Council of the City of Rockwall will be in writing. No work will be accepted without written approval from the City Engineer, or -- *in the case of franchise utilities* -- the Director of the Planning and Zoning Department. Commercial developments may have overhead utilities as approved by the City Council, otherwise all overhead utilities shall be placed underground. Relocation of existing utilities, including existing aerial utilities, shall be relocated underground.

### SECTION 1.08 | SUBMITTAL TO UTILITY COMPANIES

The developer shall be responsible for the submittal of information needed to design private utilities for a development. This information shall be submitted to the franchise utility companies (*e.g. gas, electric, phone, and cable*). Written confirmation from the franchise companies shall be submitted to the Engineering Department, verifying that the affected utility companies have installed their respective utilities prior to acceptance by the Engineering Department of the project.

### SECTION 1.09 | REQUIREMENTS OF THE FINAL ENGINEERING DRAWINGS

The final engineering drawings shall conform to the established *Engineering Drawings Requirements* and this *Standards of Design and Construction Manual*. The *Engineering Drawings Requirements* can be found the *Engineering Plan Review Checklist* in [APPENDIX 'A'](#).

The final engineering drawings will consist of drawings showing all information necessary to completely review the engineering design for improvements proposed for or affected by the site and sealed by a *Registered Professional Engineer* within the State of Texas.

### SECTION 1.10 | ENGINEERING PLAN APPROVAL AND CONSTRUCTION PERMIT RELEASE

All review fees (*i.e. plan, flood study, traffic impact analysis, lift station, etc.*) shall be paid prior to engineering construction permit release and submittal of building permit.



## SECTION 1.11 | FRANCHISE AND PUBLIC UTILITIES TO BE UNDERGROUND

All easements and right-of-way required for construction of a proposed project must be approved and accepted for filing prior to the approval or release of the final design/construction drawings.

### (A) Requirements for On-Site Easements and Right-of-Way Dedication to the City.

- (1) All easements and rights-of-way shall be dedicated on a subdivision plat. No separate instruments will be allowed.
- (2) No structures (*i.e. buildings, walls, fences, decks, swimming pools, signage/monuments, temporary/permanent storage, structures, overhangs, etc.*) are allowed in or over any easements or rights-of-way. No trees shall be planted within ten (10) feet, horizontally, of any public water or sewer line that is ten (10) inches in diameter or larger. No trees shall be planted within five (5) feet, horizontally, of any public water and sewer line less than ten (10) inches in diameter. No trees shall be planted within five (5) feet of any public storm system.
- (3) All drainage and detention easements shall be maintained, repaired, and replaced by the property owner. This statement is to be noted on the subdivision plat.
- (4) No public utilities allowed in detention easements.
- (5) All rights-of-way shall have a minimum of a ten (10) foot utility easement dedicated adjacent to them, on both sides of right-of-way.
- (6) Easement dimensions and other special requirements can be found in the utility's respective section of this *Standards of Design and Construction Manual*.
- (7) Detention pond easements and floodplain easements shall not be located on single-family residential lots for new subdivision. Easements must be located fully within an open space or a lot owned and/or maintained by a Homeowner's Association (HOA).

### (B) Requirements for Off-Site Easements Dedicated to the City.

- (1) All easement and right-of-way documents shall be written by the City of Rockwall.
- (2) The owner/developer shall furnish the City of Rockwall with a current title report for the subject property of the proposed easement, a legal description (*i.e. metes and bounds description*), and an exhibit that is signed and sealed by a *Texas Registered Professional Land Surveyor* that shows the easements or right-of-way, location, and current ownership information.
- (3) All easements shall be reviewed and approved by the City of Rockwall prior to releasing the documents for signatures by the property owners.
- (4) The individual or entity requesting the easement shall pay all filing fees required by Rockwall County.
- (5) The individual or entity shall return, to the City of Rockwall, all originally signed documents and a check for filing fees made out to Rockwall County for filing.
- (6) All filing information for all easements must be shown on all subdivision plats. Subdivision plats shall not be recorded until off-site easements have been filed and the instrument number has been included on the subdivision plat.
- (7) After recordation, a copy of the filed document will be forwarded to the property owner.

## SECTION 1.12 | FINAL ACCEPTANCE

*Final Acceptance* shall occur when all the items on the *Engineering Checklist for Final Acceptance* have been completed and signed-off on by the City of Rockwall. An example of the checklist for final acceptance has been included in the *Engineering Plan Review Checklist* in [APPENDIX 'A'](#). Items on the checklist for final acceptance will vary per project and additional items not shown on the checklist may be required. After improvements have been constructed, the developer shall be responsible for providing to the City of Rockwall *As Built* or *Record Drawings*. The design engineer shall furnish all digital files of the project, formatted in an Autodesk Civil 3D 2020 format or newer, and a PDF format on a CD-ROM disk or flash drive. The disk or drive shall include a full set of plans along with any landscaping plans, retaining wall plans, and/or detail sheets.

Submit one (1) set of printed drawings of the *Record Drawings* containing copies of all sheets. The printed sheets will be reviewed by the construction inspector **PRIOR** to producing the *Record Drawing* digital files on a disk or flash drive. This will allow any revisions to be addressed prior to producing the digital files.



The *Record Drawing Disk* shall have the design engineers seal, signature, and must be stamped and dated as *Record Drawings* or *As Built Drawings* on all sheets.

The City of Rockwall will not accept any *Record Drawing Disk* which includes a disclaimer with verbiage that is similar to or like the example verbiage provided below. A disclaimer shall not directly or indirectly state or indicate that the design engineer or the design engineer's surveyor/surveyors did not verify grades after construction, or that the *Record Drawings* were based solely on information provided by the construction contractor/contractors. Any *Record Drawings* which include a disclaimer that contains verbiage that is similar to or like the example verbiage provided below will be accepted by the City of Rockwall.

#### EXAMPLE OF ACCEPTABLE DISCLAIMER

*To the best of our knowledge ABC Engineering, Inc., hereby states that this plan is As-Built. This information provided is based on surveying at the site and information provided by the contractor.*

#### SECTION 1.13 | CHANGES IN STANDARDS OF DESIGN, CONSTRUCTION, SPECIFICATIONS, AND THIS DOCUMENT

This *Standards of Design Construction Manual* and the *Construction Specifications* contained within this document can be modified by City Council through ordinance or resolution. This document can also be updated from time-to-time to reflect changes in the City of Rockwall's requirements. The City Engineer reserves the right to correct typos or add clarifications to this document. It is the responsibility of the user to obtain the latest revisions of the City of Rockwall's requirements.





## CHAPTER 2 | STREETS

### SECTION 2.01 | GENERAL

The street system, including the street layout, shall be in accordance with generally accepted engineering practices and in compliance with the Comprehensive Plan, the latest Master Thoroughfare Plan, the Unified Development Code (UDC), the Subdivision Regulations and any other applicable regulations. The drainage system, as incorporated into the street system, shall comply with [CHAPTER 3](#) of this document. The plans and specifications, design computations, if required, and other applicable data shall be submitted to the City of Rockwall for review. Construction shall not commence prior to the approval of plans and specifications by the City's staff. All changes during construction shall be submitted to the Engineering Department for approval prior to any changes in construction.

### SECTION 2.02 | STREET ARRANGEMENT

Unless otherwise approved by the City of Rockwall, provisions shall be made for the extension of existing arterials, collector streets and local streets in accordance with the Master Thoroughfare Plan and any specific street alignments as adopted by the City Council. The alignment of future roadways in the Master Thoroughfare Plan may vary depending on design. The roadway sections in the Comprehensive Plan shall be minimums and should connect to the roadways shown in the Master Thoroughfare Plan.

Off-center intersections will be considered for approval only for *Minor Collector* and local streets and only when there is a minimum property line separation of 125-feet, unless otherwise approved by the City Engineer.

Within residential areas, the following design elements are encouraged:

- (A) Developing only a limited number of access points to arterial streets bordering the subdivision;
- (B) More than one (1) point of access;
- (C) Incorporate curvilinear streets into the plan, while having a limited impact of utility layout; and
- (D) Incorporating a discontinuous residential street network, which utilizes three (3) way intersections in lieu of four (4) way intersections.

When these factors are incorporated into a residential street plan, the result is enhanced character and traffic safety.

### SECTION 2.03 | THOROUGHFARE AND STREET GEOMETRY

Geometric design standards are presented in two (2) formats within this section. [TABLE 2.1](#) identifies specific design criteria for each standard roadway type. [FIGURE 2.1](#) and [FIGURE 2.2](#) show the typical cross-section for each standard roadway type. It should be noted that the dimensions shown are to the face of curb, unless specifically identified otherwise. It should also be noted that undivided roadways shall not be parabolic crown roadway sections.

Each roadway type is keyed to the City's Master Thoroughfare Plan, with the exception of local streets. The reader is referred to this document for information as to the locations where these roadways are to be used.



TABLE 2.1: THOROUGHFARE GEOMETRIC DESIGN STANDARDS

ABBREVIATION FOR THOROUGHFARE TYPE	P6D	A4D	M4U	MINOR COLLECTOR	M3U	R2U	ALLEY
THOROUGHFARE TYPE	PRINCIPAL ARTERIAL DIVIDED SIX (6) LANE	MINOR ARTERIAL DIVIDED FOUR (4) LANE	MAJOR COLLECTOR UNDIVIDED FOUR (4) LANE	MINOR COLLECTOR/ LOCAL COMMERCIAL UNDIVIDED	MINOR COLLECTOR WITH CONTINUOUS LEFT TURN LANE	LOCAL RESIDENTIAL	ALLEY
NUMBER TRAFFIC LANES	6	4	4	2	2	2	1
MINIMUM LANE WIDTH (FEET)	12	12	11	11 + 2 PARKING	12	14	12
MINIMUM ROW WIDTH (FEET) <sup>1</sup>	110	85	65	60	70	50	20
DESIGN SPEED (MPH)	45	40	35	30	30	30	20
POSTED SPEED (MPH)	40	35	30	25	30	N/A	N/A
STOPPING SIGHT DISTANCE (FEET)	400	325	275	200	200	200	125
MEDIAN WIDTH (FEET) <sup>2</sup>	16	14	N/A	N/A	LEFT TURN LANE WIDTH <sup>14</sup>	N/A	N/A
MINIMUM LATERAL CLEARANCE (FEET)	6	6	6	6	6	N/A	N/A
PARKING PERMITTED	NO	NO	NO	C = SOME R = YES	NO	R = YES	NO
MINIMUM HORIZONTAL CENTERLINE CURVATURE (FEET)	1200	850	C = 700 R = 600	C = 500 R = 350	C = 500 R = 350	R = 250 ELBOW = 50	SEE DETAILS
CREST VERTICAL CURVE MINIMUM K VALUE	120	80	50	30	30	30	10
SAG VERTICAL CURVE MINIMUM K VALUE	90	70	50	40	40	40	20
MAXIMUM GRADE (%)	7.5 <sup>3</sup>	7.5 <sup>3</sup>	7.5	7.5	7.5	10.0	10.0
MINIMUM GRADE (%)	0.7	0.7	0.7	0.7	0.7	0.7	0.7

**KEY:**

R: RESIDENTIAL

C: COMMERCIAL

MPH: MILES PER HOUR

**NOTES:**

<sup>1</sup>: RIGHT-OF-WAY REQUIREMENTS FOR STATE HIGHWAYS AND/OR THE PROVISION OF RIGHT TURN LANES OR OTHER INTERSECTION IMPROVEMENTS MAY EXCEED THIS MINIMUM R.O.W. STANDARD.

<sup>2</sup>: LARGER MEDIANS MAY BE REQUIRED TO PROVIDE FOR MULTIPLE TURN LANES.

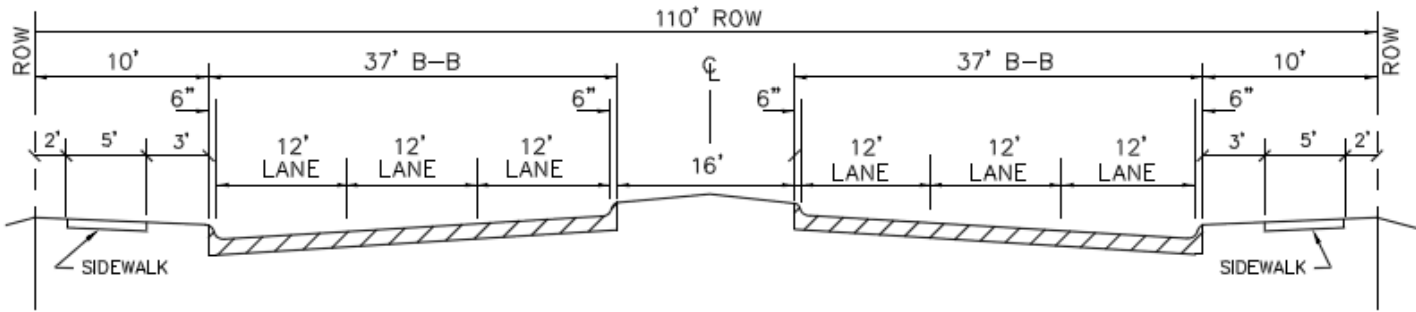
<sup>3</sup>: FOR MAXIMUM LENGTH OF 200-FEET.

**GENERAL NOTES**

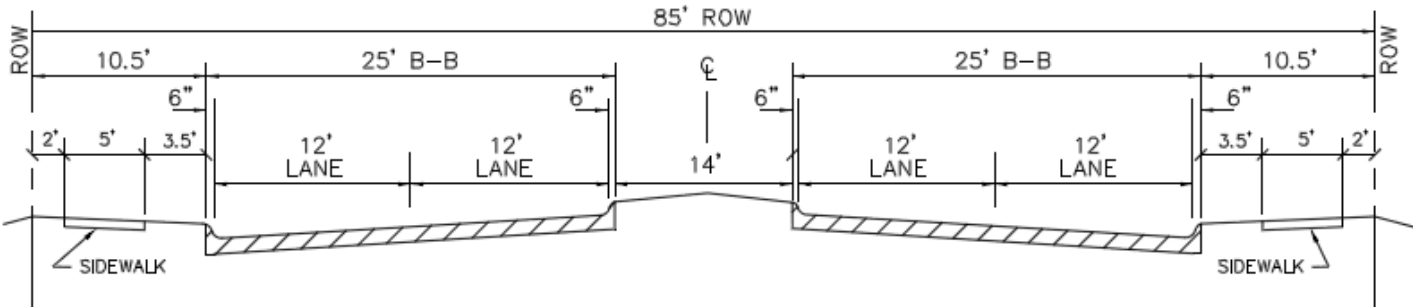
(A) LOCAL RESIDENTIAL CUL-DE-SACS SHALL HAVE A MINIMUM R.O.W. RADIUS OF 57.5-FEET.

(B) CROSS-SLOPE VARIANCE NEEDS APPROVAL FROM CITY ENGINEER.

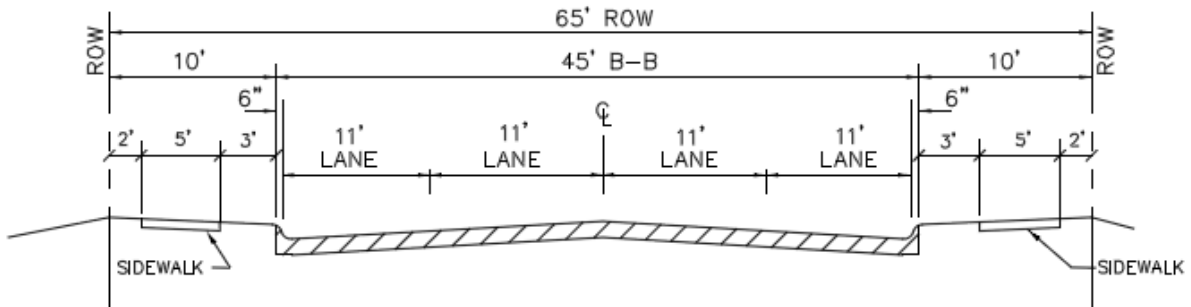
FIGURE 2.1: TYPICAL THOROUGHFARE CROSS SECTIONS



PRINCIPAL ARTERIAL DIVIDED 6-LANE  
P6D



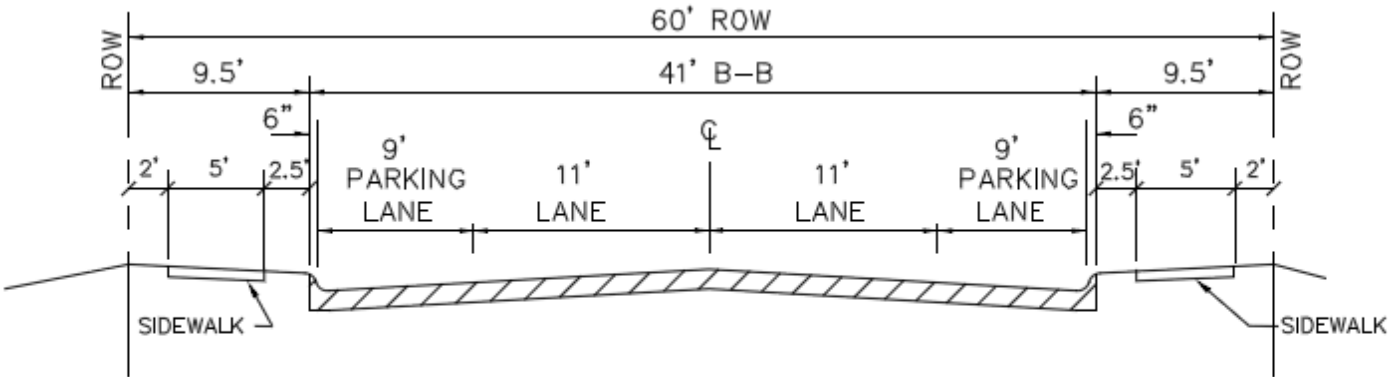
MINOR ARTERIAL DIVIDED 4-LANE  
A4D



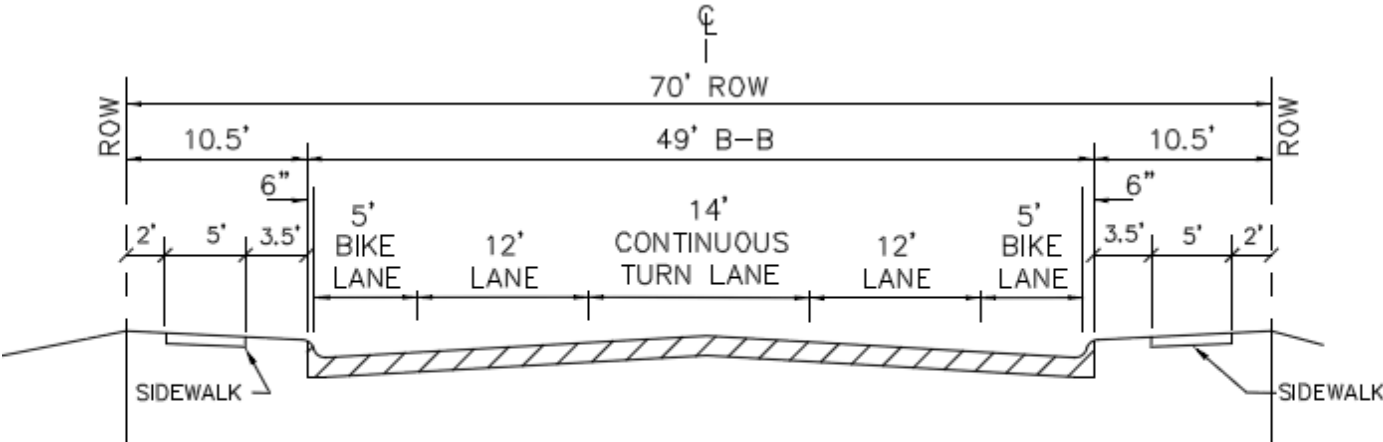
MAJOR UNDIVIDED COLLECTOR 4-LANE  
M4U



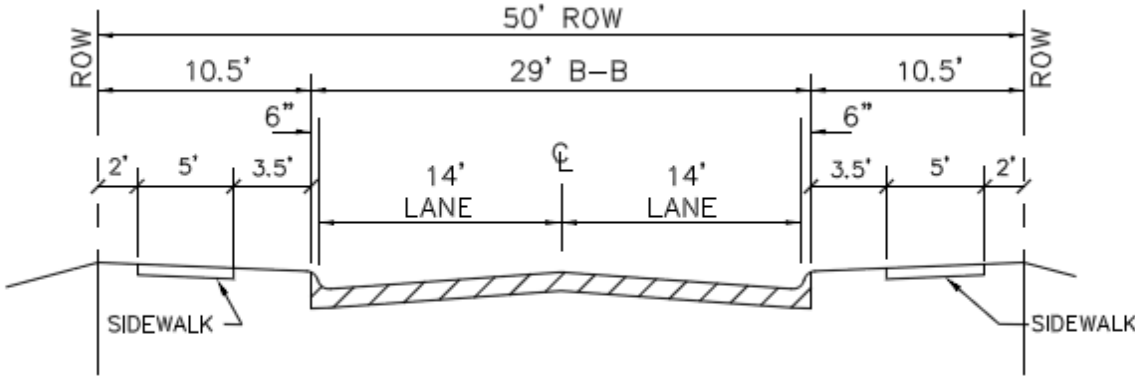
FIGURE 2.2: TYPICAL THOROUGHFARE CROSS SECTIONS



MINOR COLLECTOR AND/OR LOCAL COMMERCIAL UNDIVIDED

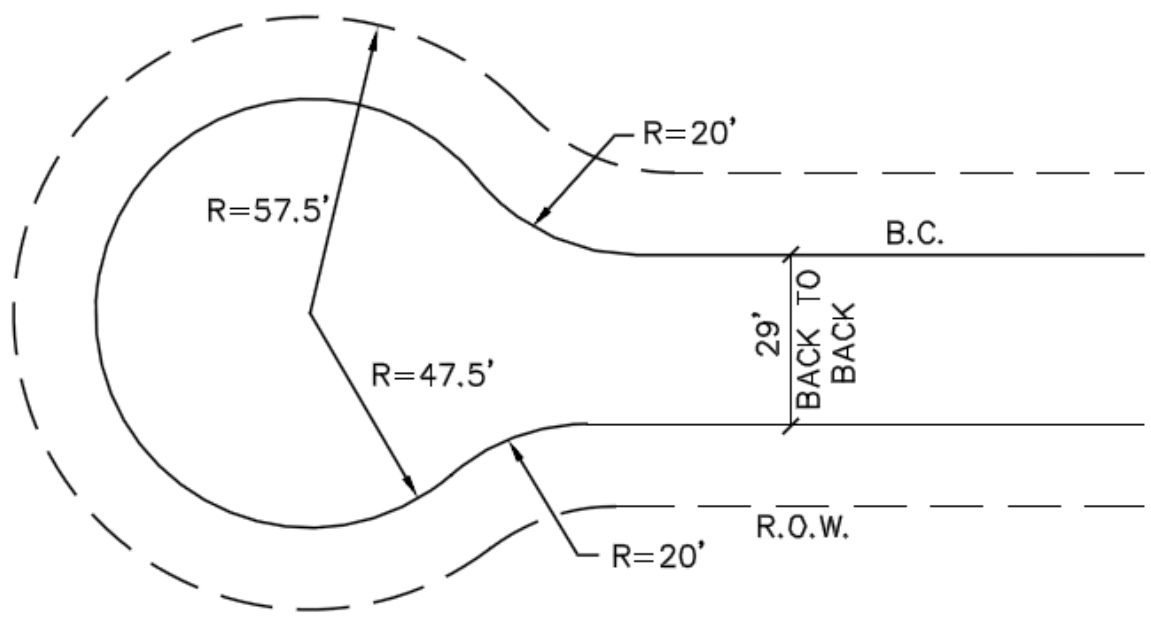


MINOR COLLECTOR - 2 LANE WITH CONTINUOUS LEFT TURN LANE  
M3U

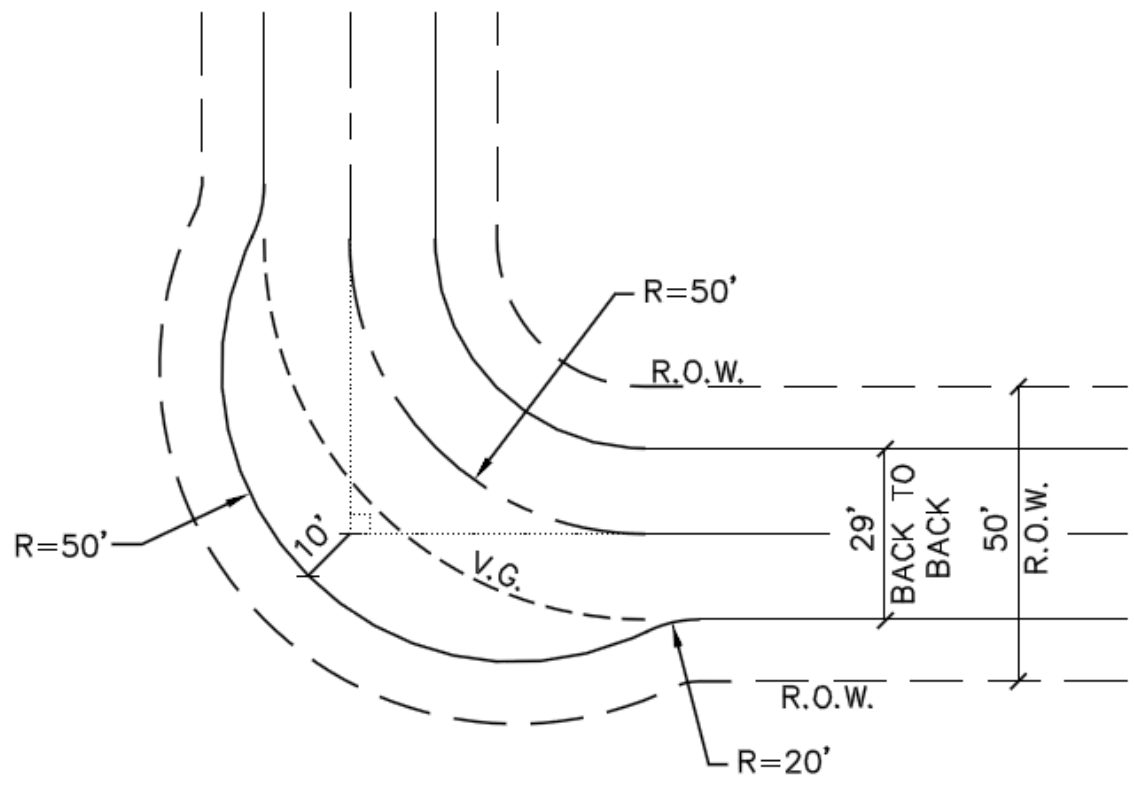


LOCAL (RESIDENTIAL STREET)

FIGURE 2.3: TYPICAL THOROUGHFARE CROSS SECTIONS



TYPICAL CUL-DE-SAC



TYPICAL EYEBROW



## SECTION 2.04 | TURN LANES

All left turn storage areas shall be a minimum 11-foot wide with minimum storage requirements for left-turn lanes as in [TABLE 2.2](#). The transition curves used in left-turn lanes shall be two (2), 250-foot radius reverse curves with a total transition length of 100-feet. Medians less than seven (7) feet wide (*face-to-face*) are required to be constructed of reinforced integral stained and stamped color concrete a minimum of six (6) inches thick median pavement. All median noses are to be constructed of City approved integral stained and stamped color concrete. The color and pattern to be approved by the City. The stamped color concrete system shall be installed within a minimum distance of ten (10) feet from the end of the nose.

## SECTION 2.05 | MEDIAN OPENINGS, WIDTH, LOCATION AND SPACING

Arterial thoroughfares in the City of Rockwall shall have raised medians. Arterials having continuous two (2) way left turn lanes may be utilized only in special circumstances with the approval of the City Council. Median openings at intersections shall be from right-of-way to right-of-way of the intersecting street, unless otherwise approved by the City Engineer. The width of mid-block median openings shall not be less than 60-feet, but no greater than 70-feet.

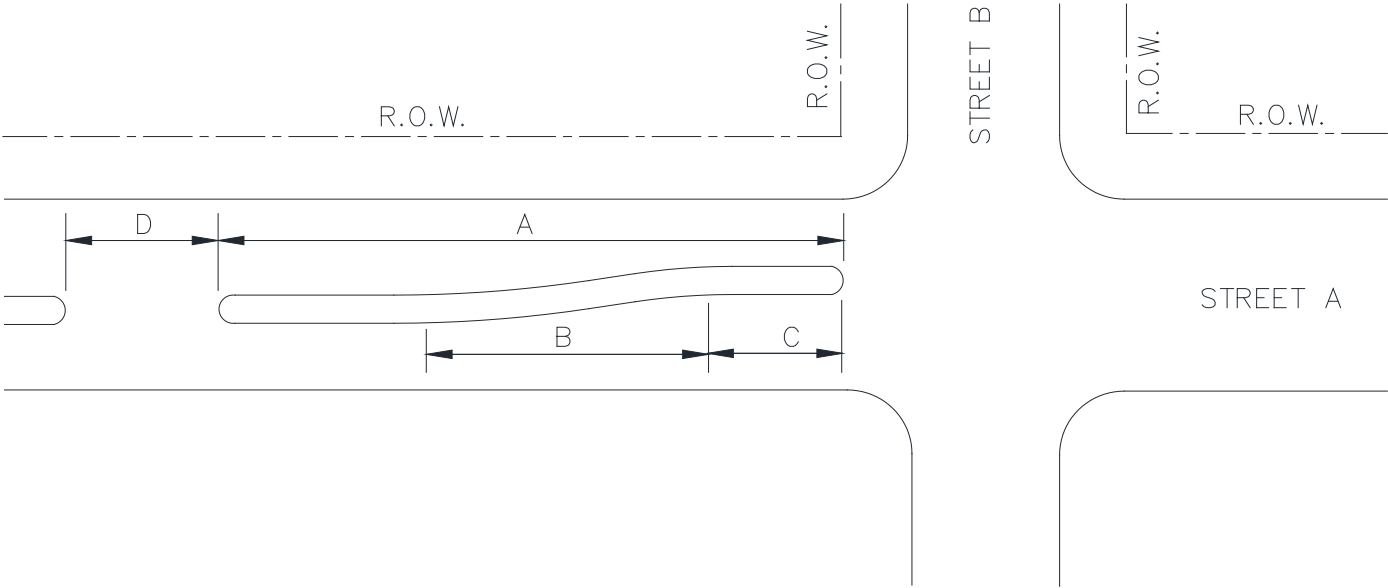
Using the above requirements, examples of the minimum distance between median openings on a divided street where left-turn storage is provided in both directions are:

- (A) 310-feet from *nose-to-nose* of the median from the intersection of two (2) major thoroughfares to a street or drive [see [TABLE 2.2: MEDIAN DESIGN STANDARDS](#)];
- (B) 260-feet from *nose-to-nose* of the median from the intersection of two (2) secondary thoroughfares or a secondary thoroughfare and a major thoroughfare to a residential street or drive, and;
- (C) 220-feet from *nose-to-nose* of the median for intersection combinations of drives and/or residential streets.

Medians less than seven (7) feet and minimum of three (3) feet wide are required to be constructed of a City approved stamped integral color concrete system with concrete curb and gutter. All median noses are to be constructed of City approved stamped integral color concrete system, a distance of ten (10) feet from the end of the nose. Any median that has landscaping is required to have a mow ramp for access, and install all standard street lighting and conduit for irrigation. Noses shall be a solid poured steel reinforced concrete bullet nose. Pavers shall only be considered for existing medians that currently have pavers.



**TABLE 2.2: MEDIAN DESIGN STANDARDS**



INTERSECTING STREET TYPE		MINIMUM LENGTH (FEET)			
STREET A	STREET B	A	B	C <sup>1</sup>	D <sup>2</sup>
PRINCIPAL ARTERIAL, SIX (6) LANES	PRINCIPAL ARTERIAL, SIX (6) LANES	310	100	150	60
PRINCIPAL ARTERIAL, SIX (6) LANES	MINOR ARTERIAL, FOUR (4) LANES	260	100	100	60
PRINCIPAL ARTERIAL, SIX (6) LANES	MINOR ARTERIAL, FOUR (4) LANES MINOR ARTERIAL, TWO (2) LANES	260	100	100	60
PRINCIPAL ARTERIAL, SIX (6) LANES	LOCAL OR PRIVATE, TWO (2) LANES	220	100	60	60
MINOR ARTERIAL, FOUR (4) LANES	PRINCIPAL ARTERIAL, SIX (6) LANES	310	100	150	60
MINOR ARTERIAL, FOUR (4) LANES	MINOR ARTERIAL, FOUR (4) LANES	260	100	100	60
MINOR ARTERIAL, FOUR (4) LANES	MINOR ARTERIAL, FOUR (4) LANES MINOR ARTERIAL, TWO (2) LANES	260	100	100	60
MINOR ARTERIAL, FOUR (4) LANES	LOCAL OR PRIVATE	220	100	60	60

**NOTES:**

<sup>1</sup>: MINIMUM LENGTH/ACTUAL LENGTH DEPENDENT UPON ANTICIPATED TURN VOLUME.

<sup>2</sup>: OR STREET WIDTHS EIGHT (8) FEET OR GREATER, WHICHEVER IS GREATER. A VARIANCE MAYBE GRANTED BY THE CITY COUNCIL ON A CASE BY CASE BASIS.

**GENERAL NOTES**

- (A) LEFT-TURN LANE STORAGE AREA WIDTH 11-FEET MINIMUM
- (B) MEDIAN WIDTH (SEE GEOMETRIC DESIGN STANDARDS FOR PRINCIPAL AND MINOR ARTERIAL)



## SECTION 2.06 | DRIVEWAY LOCATIONS

- (A) Minimum standards for driveway separation accessing the same site are shown in [FIGURE 2.4](#). This standard applies to all non-residential uses.
- (B) Residential driveways shall be located so that the curb return does not extend past the property line, and meets the separation distance to curb inlets and street intersections.
- (C) There is a minimum distance upstream and downstream from the adjacent intersections within which driveways should not be located. This separation distance varies with the classification of street and is shown in [FIGURE 2.4](#). This standard applies to all non-residential users.
- (D) At mid-block access points, there is a minimum distance from a median nose, within which driveways should not be located. This is shown in [FIGURE 2.4](#) and is equally applicable along both arterials and collectors for non-residential uses.
- (E) All proposed paving connections to existing concrete paving requires a longitudinal butt joint connection. For proposed paving connections to existing asphalt, the concrete will be butted up with a smooth transition.
- (F) Developing or developed residential lots shall have a minimum of one (1) driveway. Cross access between lots shall not be the only access to a property, and is only allowed by special approval (see [CHAPTER 38, SUBDIVISIONS, OF THE MUNICIPAL CODE OF ORDINANCES](#)).

### SUBSECTION 2.06.01 | DRIVEWAYS ON TXDOT FACILITIES

Driveways on TXDOT facilities shall be placed in accordance to the City of Rockwall's standards as set forth in this section and the requirements of the current TXDOT's *Access Management Manual* and require TXDOT *Driveway Permit* approval. TXDOT *Driveway Permits* shall be processed through the City of Rockwall's Engineering Department. TXDOT *Permit Plan* sets shall be 11" x 17" in size and signed and sealed by a licensed professional engineer with the State of Texas. Permit plan sets shall include: [1] typical sections, [2] paving plan and profile, [3] all applicable TXDOT standard details, [4] traffic control plans sheets, [5] striping plans, [6] demo plans, [7] drainage plans (*i.e. drainage area map, storm sewer plans and profiles, culvert plans and profiles*), and [8] any other items required by TXDOT or City Engineer to construct the driveway. A Traffic Impact Analysis (TIA) shall be submitted to the Engineering Department with all new driveway and roadway locations that require TXDOT *Driveway Permits*.

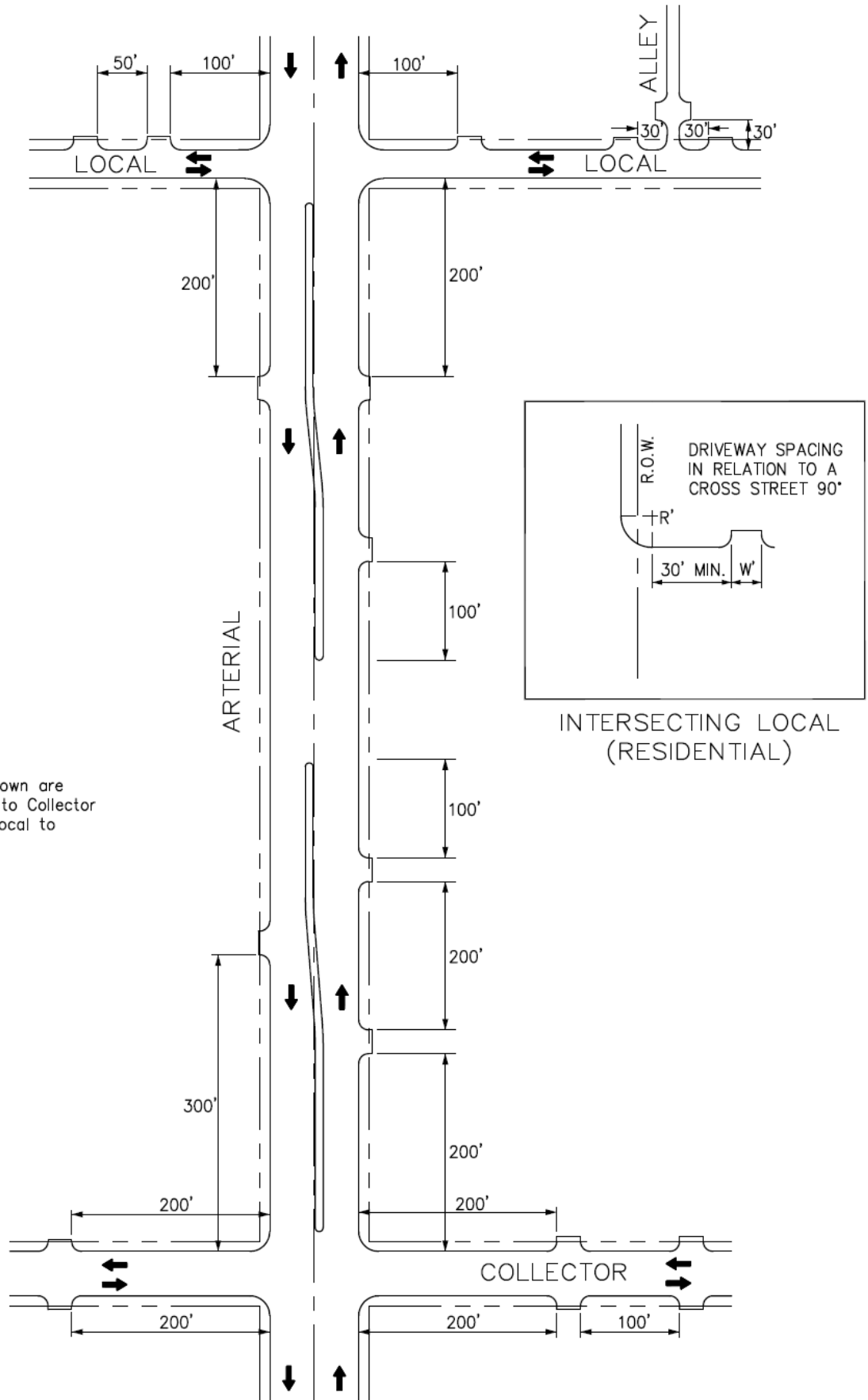
## SECTION 2.07 | BLOCK LENGTHS

In general, streets shall be provided at such intervals as to serve cross traffic adequately and to intersect with existing streets. Where no existing subdivision plats control, the blocks shall be not more than 1,600-feet in length. Block arrangements must provide access to all lots, and in no case, shall a block interfere with traffic circulation.





FIGURE 2.4: MINIMUM DRIVEWAY SPACING AND CORNER CLEARANCE



NOTE:  
 All dimensions shown are minimums. Local to Collector to be same as Local to Arterial.



## SECTION 2.08 | STREET INTERSECTIONS

More than two (2) streets intersecting at one (1) point is not permitted. All streets and thoroughfares should intersect other streets and thoroughfares at a 90-degree angle unless otherwise approved by the City Engineer. Arterial and collector street intersections shall have property line corner clips with a minimum tangent distance of 30-feet. Residential streets shall not normally be required to have a right-of-way corner clip at their intersection with other streets or thoroughfares, but a minimum of a ten (10) foot by ten (10) foot sidewalk corner easement will be required. Visibility easements will be required for all intersections. For all intersections that are not 90-degrees, an engineered visibility easement is required by the design engineer. The standard visibility easements for intersections that are 90-degrees, are as follows:

- (A) Arterial/Collector Street Intersections: 30' x 30' Easement
- (B) Residential Street Intersections: 20' x 20' Easement
- (C) Alley to Street Intersections: 10' x 10' Easement

Curb radii at intersections shall have a minimum radius of 30-feet along arterials, 25-feet along collectors, and 20-feet along residential streets. In any case where streets intersect at an angle of other than 90-degrees or have non-standard utility locations or have non-standard ADA ramp configurations, the City may require non-standard right-of-way corner clips, easements, and curb return radii. All proposed paving connections to existing concrete paving require a longitudinal butt joint connection.

## SECTION 2.09 | RELATION TO ADJOINING STREETS

The system of streets designed for a development, except in unusual cases, must connect with streets already dedicated in adjacent developments. Where no adjacent connections are platted, the streets must be the reasonable projection of streets in the nearest subdivided tracts and must be continued to the boundaries of the tract development, so that other developments may eventually connect with the proposed development. Strips of land controlling access to or egress from other property or any street or alley or having the effect of restricting or damaging the adjoining property for development or subdivision purposes or which will not be taxable or accessible for special improvements shall not be permitted in any development unless such reserve strips are conveyed to the City on a fee simple basis. This determination is made by the Director of Planning and Zoning and/or the City Engineer. When such access is needed to maintain permanent City owned utilities, the roadway will be an improved right-of-way. If the utilities are temporary, improved temporary easement may be approved.

## SECTION 2.10 | DEAD-END STREETS, CUL-DE-SACS, AND COURTS

Cul-de-sacs are permitted within residential subdivisions. Use of this design shall provide proper access to all lots and shall not exceed 600-feet in length, measured from the center of the cul-de-sac to the center of the intersecting street (*not a dead-end street*). Cul-de-sac shall have a minimum paving radius of 47½-feet and a minimum right-of-way radius of 57½-feet. Specific aspects of the standard cul-de-sac design are given in [FIGURE 2.3](#). In lieu of the typical design shown, the City may approve alternative concepts for a specific application.

For phased residential developments, temporary cul-de-sacs may be used or be required by the City. The material of the temporary cul-de-sac pavement shall be approved by the City Engineer. Paving of the temporary cul-de-sac shall be placed in a manner as to be removed in the future without impacting the main paving. Dead end streets are to be extended to a future phase and may not exceed one (1) lot depth past an intersection without a cul-de-sac.

## SECTION 2.11 | ALLEYS AND ALLEY WIDTHS

Alleys shall be provided in all residential areas and shall be paved with steel reinforced concrete. No alley may be over 1,000-feet long. The City Council may waive the residential alley requirement, if it is in the best interest of the City. Alleys may be required in commercial and industrial districts. The City may waive this requirement where other definite and assured provisions are made for service access such as off-street loading, unloading, and parking consistent with and adequate for the uses proposed. The minimum right-of-way width of an alley shall be 20-feet. Dead-end alleys shall not be permitted. The City may waive this requirement where such dead-end alleys are unavoidable and where adequate turnaround facilities have been provided. Adequate provisions shall be made at all intersections in order that equipment (*e.g. garbage collection vehicles and maintenance vehicles*) can maneuver the corners. The interior edge of the pavement, at the corners, shall have a minimum radius of 30-feet. The exterior edge of the pavement, at the corners, shall have a minimum radius of 20-feet. The alley paving is to be flared at the street intersection. The right-of-way limits shall be expanded, if necessary, beyond the minimum requirement in order to include all of the paved section and utilities within the right-of-way of the alley.



Alley turnouts shall be paved to the property line and shall be 15-feet wide at that point. All alleys shall have a minimum of 12-feet of steel reinforced paved concrete roadway. Alleys shall have a minimum thickness of seven (7) inches on the exterior edges and five (5) inches in the center sections.

## SECTION 2.12 | STREET GRADES

Arterial streets may have a maximum grade of seven and one-half (7½) percent, for a maximum continuous distance of 200-feet. Collector streets may have a maximum grade of seven and one-half (7½) percent. Residential streets may have a maximum grade of ten (10) percent, unless otherwise approved by the City, where the natural topography is such as to require steeper grades. All streets must have a minimum grade of at least 0.70 of one (1) percent. Centerline grade changes with an algebraic difference of more than one (1) percent shall be connected with vertical curves in compliance with the minimum length requirements set forth in [TABLE 2.3](#), [TABLE 2.4](#), [TABLE 2.5](#), and [TABLE 2.6](#).

**TABLE 2.3: CREST VERTICAL CURVES**

DESIGN SPEED (MPH)	COEFFICIENT OF FRICTION <sup>1</sup>	STOPPING SITE DISTANCE (FEET)	STOPPING SITE DISTANCE FOR DESIGN (FEET)	K	K ROUNDED FOR DESIGN
15	0.42	72.98	75	4.01	5
20	0.40	106.83	125	8.59	10
25	0.38	146.70	150	16.19	20
30	0.36	193.58	200	28.20	30
35	0.34	248.72	250	46.55	50
40	0.32	313.67	325	74.03	80
45	0.31	383.12	400	110.44	120

### NOTES:

<sup>1</sup>: AASHTO, PAGE 316

**TABLE 2.4: MINIMUM LENGTH OF VERTICAL CURVE IN FEET (ROUNDED)**

*NOTE: FOR SPEEDS AND K VALUES SHOWN BELOW (L=KA)*

ALGEBRAIC GRADE DIFFERENCE (%) [A]	MPH	15	20	25	30	35	40	45
	K	5	10	20	30	50	80	120
1	5	10	20	30	50	80	120	
2	10	20	40	60	100	160	240	
3	15	30	60	90	150	240	360	
4	20	40	80	120	200	320	480	
5	25	50	100	150	250	400	600	
6	30	60	120	180	300	480	720	
7	35	70	140	210	350	560	840	
8	40	80	160	240	400	640	960	
9	45	90	180	270	450	720	1080	
10	50	100	200	300	500	800	1200	
11	55	110	220	330	550	880	1320	
12	60	120	240	360	600	960	1440	
13	65	130	260	390	650	1040	1560	
14	70	140	280	420	700	1120	1680	
15	75	150	300	450	750	1200	1800	

**TABLE 2.5: SAG VERTICAL CURVES**

DESIGN SPEED (MPH)	COEFFICIENT OF FRICTION <sup>1</sup>	STOPPING SITE DISTANCE (FEET)	STOPPING SITE DISTANCE FOR DESIGN (FEET)	K	K ROUNDED FOR DESIGN
15	0.42	72.98	75	8.13	10
20	0.40	106.83	125	14.75	20
25	0.38	146.70	150	23.56	30
30	0.36	193.58	200	34.78	40
35	0.34	248.72	250	48.69	50
40	0.32	313.67	325	65.69	70
45	0.31	383.12	400	84.31	90

### NOTES:

<sup>1</sup>: AASHTO, PAGE 316

**TABLE 2.6: MINIMUM LENGTH OF VERTICAL CURVE IN FEET (ROUNDED)**NOTE: FOR SPEEDS AND K VALUES SHOWN BELOW ( $L=KA$ )

ALGEBRAIC GRADE DIFFERENCE (%) [A]	MPH	15	20	25	30	35	40	45
	K	10	20	30	40	50	70	90
1	10	20	30	40	50	70	90	
2	20	40	60	80	100	140	180	
3	30	60	90	120	150	210	270	
4	40	80	120	160	200	280	360	
5	50	100	150	200	250	350	450	
6	60	120	180	240	300	420	540	
7	70	140	210	280	350	490	630	
8	80	160	240	320	400	560	720	
9	90	180	270	360	450	630	810	
10	100	200	300	400	500	700	900	
11	110	220	330	440	550	770	990	
12	120	240	360	480	600	840	1080	
13	130	260	390	520	650	910	1170	
14	140	280	420	560	700	980	1260	
15	150	300	450	600	750	1050	1350	

**SECTION 2.13 | PAVEMENT DESIGN**

Traffic projections for next 30-years, engineered paving designs, and sub-grade conditions are required for the pavement design section determinations of all collector and arterial streets.

**SUBSECTION 2.13.01 | SUBGRADE**

Subgrades shall be compacted and finished to a smooth uniform surface. All public roadways shall use a minimum six (6) inch lime stabilized subgrade or eight (8) to ten (10) inches of approved flexbase. The lime stabilization shall be used for the full width of the street, back-of-curb to back-of-curb, plus 12-inches on the outside of the curb. The minimum lime content shall be six (6) percent of the dry weight of the material (*i.e. at least 27 LBS per square yard*). Lime stabilization or cement stabilization may be required for soils showing a PI of 15 or less. Type of stabilization and paving design will be determined prior to pavement construction by a certified geotechnical testing lab. The subgrade materials will be tested and installed in accordance to the North Central Texas Council of Government's (NCTCOG's) *Standard Specifications for Construction*, unless otherwise approved by the City of Rockwall. In general, the soils testing will include the testing of Atterberg limits and testing of sulfates to determine if lime stabilization is infeasible. Laboratory tests must be submitted to the Engineering Department for approval. Subgrades should be compacted to 95% standard densities. No sand is allowed under any paving or pedestrian facility.

**SUBSECTION 2.13.02 | STEEL REINFORCED CONCRETE PAVEMENT**

All pavement shall be steel reinforced concrete. Size and spacing shall conform to [TABLE 2.7](#) below. All non-structural cracks in paving shall be routed and sealed as determined by the City. All reinforcing steel placed within the public right-of-way shall be grade 60 steel and comply with Texas Department of Transportation (TXDOT) specifications.

Fly ash may be used in concrete pavement locations provided that the maximum cement reduction does not exceed 20% by weight per cubic yard of concrete. The fly ash replacement shall be 1.25 pounds per one (1) pound of cement reduction (*i.e. 1.25:1*).

At a minimum all concrete pavement shall conform to [TABLE 2.7](#).

**TABLE 2.7: STEEL REINFORCED CONCRETE PAVEMENT DESIGN**

STREET/PAVEMENT TYPE	MINIMUM THICKNESS (INCHES)	STRENGTH 28-DAY (PSI)	MINIMUM CEMENT (SACKS / CY)		STEEL REINFORCEMENT		SLUMP (INCHES)
			MACHINE PLACED	HAND PLACED	BAR #	SPACING (OCEW)	
ARTERIAL <sup>1</sup>	10"	3,600	6.0	6.5	#4 BARS	18"	3"-5"
COLLECTOR <sup>1</sup>	8"	3,600	6.0	6.5	#4 BARS	18"	3"-5"
RESIDENTIAL	6"	3,600	6.0	6.5	#3 BARS	24"	3"-5"



ALLEY	7"-5"-7"	3,600	6.0	6.5	#3 BARS	24"	3"-5"
FIRE LANE	6"	3,600	6.0	6.5	#3 BARS	24"	3"-5"
DRIVEWAYS OUTSIDE ROW	6"	3,600	6.0	6.5	#3 BARS	24"	3"-5"
DRIVEWAY APPROACHES WITHIN ROW	TO MATCH DESIGN OF STREET PAVEMENT TYPE CONNECTING INTO						
BARRIER FREE RAMPS	6"	3,600	N/A	6.5	#3 BARS	24"	3"-5"
SIDEWALKS	4"	3,000	N/A	5.5	#3 BARS	24"	3"-5"
TRAILS	6"	3,600	N/A	6.5	#3 BARS	24"	3"-5"
PARKING LOT/DRIVE AISLES	5"	3,000	5.0	5.5	#3 BARS	24"	3"-5"
DUMPSTER PADS	7"	3,600	6.0	6.5	#3 BARS	24"	3"-5"

#### **NOTES:**

<sup>1</sup>: PAVING SECTION DESIGNS FOR ARTERIALS AND COLLECTORS SHALL BE BASED OFF 30-YEAR PROJECTED TRAFFIC VOLUMES AND GEOTECHNICAL ANALYSIS/REPORT. PAVING SECTION DESIGN SHALL INCLUDE BUT NOT BE LIMITED TO THE FOLLOWING: PAVEMENT THICKNESS, REINFORCING SIZE AND SPACING, PAVEMENT STRENGTH, SUBGRADE THICKNESS, SUBGRADE TREATMENT TYPE (E.G. LIME OR CEMENT).

Concrete batch designs for all paving, sidewalks, trails, and sewer/storm structures are to be reviewed and approved by the Engineering Department. All batch designs shall be submitted with history of recent (*i.e. one [1] year or newer*) cylinder breaks for each separate strength requirement (*machine placement and hand placed*). All batch designs shall have the current date, project name, and use labeled on each design. Submit batch designs to the Engineering Department a minimum of ten (10) days prior to the projected placement date for review and approval.

During construction the contractor shall furnish the following at his/her own expense:

- (A) Batch plant control from a qualified commercial laboratory. Laboratory personnel shall be competent to determine free moisture in aggregates and make needed adjustments in control of the mix and slump.
- (B) Prepare a minimum four compression cylinders for each 150 cubic yards of concrete or fraction thereof, with one (1) cylinder break at seven (7) days, one (1) at 14-days, and a minimum of two (2) cylinders broken at 28-days.

*NOTE: NO AVERAGING ON CYLINDER BREAKS.*

- (C) Testing labs are to submit copies of any and all concrete cylinder breaks that do not meet 28-day break specifications. Cores are to be taken within ten (10) days of any 28-day cylinder break failures.
- (D) Test data and copies of all laboratory reports for site work are to be directed to the attention of the designated engineering construction inspector that is assigned to the project.

The City of Rockwall may suspend concreting operations if the quality of the concrete being placed is not acceptable or due to adverse weather conditions. Concrete shall not be placed during rain events. Concrete placement shall cease if rain begins, and uncured concrete shall be protected from the rain. Concrete placement shall cease if the concrete temperature meets or exceeds 95-degrees Fahrenheit. If, in the opinion of the owner or the City of Rockwall, a combination of temperature, wind, and humidity create conditions that are adversely affecting the condition of the concrete, concrete placement operations shall cease. Concrete placement shall also cease if concrete temperature is below 40-degrees Fahrenheit and falling. Except by specific written authorization of the owner or the City of Rockwall, no concrete shall be placed when the air temperature is less than 40-degrees Fahrenheit and falling, but may be placed when the air temperature is above 35-degrees Fahrenheit and rising -- *Pending No Freezing Weather is Imminent* -- with the temperature being taken in the shade away from artificial heat. When and if such permission is granted, the contractor shall furnish sufficient protective material and devices to enclose and protect the fresh concrete in such a way as to maintain the temperature of 50-degrees Fahrenheit for a period of at least five (5) days. No concrete shall be placed on wet or frozen subgrades. It is to be distinctly understood that the contractor is responsible for the quality and strength of the concrete placed under any weather conditions. Any concrete that is damaged by weather conditions shall be replaced at no cost to the City.

*High Early Strength Concrete* is allowed. *High Early Strength Concrete* may be required by the City Engineer in certain conditions, such as to allow for a roadway to be open without traffic control in a short period of time.

Maximum time intervals between the addition of mixing water and/or cement to the batch, and the placing of concrete in the forms shall not exceed the following:



### NON-AGITATED CONCRETE

AIR OR CONCRETE TEMPRATURE WHICH EVER IS HIGHER	MAXIMUM TIME FROM ADDITION OF WATER TO PLACEMENT
UP TO 80° F	30 MINUTES
ABOVE 80° F	15 MINUTES

### AGITATED CONCRETE

AIR OR CONCRETE TEMPRATURE WHICH EVER IS HIGHER	MAXIMUM TIME FROM ADDITION OF WATER TO PLACEMENT
UP TO 75° F	90 MINUTES
75° TO 89° F	60 MINUTES
OVER 89° F	45 MINUTES

The use of an approved set-retarding admixture will permit the extension of the above time maximums, by 30-minutes for agitated concrete only.

## SECTION 2.14 | PARKWAYS, GRADES, AND SIDEWALKS

All parkways shall be constructed to conform to top of curb grades with a standard transverse slope of ¼-inch per foot rise from top of curb to right-of-way. Prior to City acceptance, all City rights-of-way shall be sodded where disturbed. Where the natural topography is such as to require steeper grades, transverse slopes (*except for sidewalks*) up to ¾-inch per foot may be used with the approval of the City of Rockwall.

Sidewalks shall be provided for all streets. Barrier free ramps and sidewalks/trails along screening walls, landscaped areas, parks, open space, greenbelts, and/or drainage ways, shall be installed by the *Developer* with street construction. The sidewalks/trails in front of and along sides of residential lots shall be installed by the home builder. The City may require sidewalks in other locations. Sidewalks shall be minimum of five (5) feet in width and shall have two (2) feet of green space between the right-of-way line and the outside edge of sidewalk. Sidewalks shall be located wholly within the street right-of-way, sidewalk corner clip, pedestrian and/or road easement. If a fire hydrant or other appurtenance is too close to the sidewalk, the sidewalk may be swerved toward the right-of-way line to maintain five (5) foot clear path. If sidewalk has to be built outside the right-of-way, a sidewalk easement is required. This requirement may be waived by the City Council.

Sidewalks/Trails wider than six (6) feet will be required to have engineered details. Sidewalks placed adjacent to the back of the curb must be six (6) feet wide and lugged into the curb. Sidewalks placed against the back of curb shall be approved by the City Engineer.

If a trail or sidewalk system extends farther than 0.25-miles along the path from a public roadway or paved area, the trail or sidewalk must be a minimum of ten (10) feet wide, and constructed to fire lane specifications. Trails shall be installed as per the City's Master Trail Plan contained in the Comprehensive Plan. A trail easement shall be dedicated for areas where a trail extends outside of right-of-way.

Sidewalks or trails shall be constructed continuously along street frontage from property line to property line. If neighboring property is owned by a franchise utility or a public entity, sidewalk may be required to extend half the distance across neighboring property. Sidewalks shall extend past the property line into the right-of-way to connect to a ramp.

Mid-block crossings shall only be allowed by City Engineer's approval. Additional requirements may be required to allow for the crossing.

### SUBSECTION 2.14.01 | ROADWAY RECONSTRUCTION

During a roadway reconstruction project, if a block of a street -- *to be reconstructed* -- does not currently have sidewalks in place, a six (6) foot sidewalk against/adjacent to the curb or a minimum five (5) foot sidewalk not adjacent to the curb shall be required on both sides of the roadway within that street block if the following criteria are met:

- (A) The roadway is above a residential/local classification or on the currently adopted Master Thoroughfare Plan (*i.e. Minor Collector, Major Collector, Minor Arterial and Principal Arterial*) and has an Average Daily Traffic (ADT) of 750 vehicles or more per day; or,



- (B) Any portion of the street block is located within 1,000 feet of a school, city park, or church. In cases where the street block is located within this 1,000-foot buffer, the street block shall have a direct connection to another street block or sidewalk system that is also located within the 1,000-foot buffer. Any street block or sidewalk system that is inhibited from connecting to an existing street block or sidewalk system by a physical barrier (e.g. bridges) may be exempted from this requirement at the discretion of the City Engineer.

**NOTE:** For the purpose of this section a street block shall be defined as the section of the road that extends from one (1) street intersection to another, or from a street intersection to the end of a cul-de-sac or dead-end. This section shall only apply to City initiated reconstruction projects.

## SECTION 2.15 | DRIVEWAYS/DRIVE AISLES

All drive approaches (*surface between the City roadway and the property line/right-of-way*) are to be maintained, repaired, and replaced by the property owner in accordance with the City of Rockwall's requirements. Drive approaches connecting to *curb-and-gutter* streets must be by full curb and gutter removal. HORIZONTAL CURB CUTS ARE NOT ALLOWED.

### SUBSECTION 2.15.01 | RESIDENTIAL

Steel reinforced concrete residential driveways that serve single car garages shall not be less than 12-feet in width. Two (2) car garages, carports, and/or storage areas shall not be less than 18-feet and no more than 24-feet in width at the property line. The width of the driveway for a three (3) car garage shall be 28-feet or larger (*to be reviewed on a case-by-case basis*).

Residential driveways shall be separated from one another by a distance of at least ten (10) feet at the start of the approach radius. The radii of all residential driveway returns shall be a minimum of five (5) feet and shall not extend past the adjoining property line. The driveway approaches devoted to one (1) use shall not occupy more than 60% of the frontage abutting the roadway or alleyway.

If a residential lot has frontage on both a residential street or alleyway and frontage on a collector or arterial, the driveway must be on the lower classified roadway. If a residential lot only has frontage on a collector or arterial roadway, the residential lot may connect to this classification and must meet driveway spacing requirement to said roadway. If a residential lot is allowed to connect to a collector or arterial roadway, the driveway must be designed so that the resident lot does not back out into traffic utilizing a driveway configuration such as by a circle drive or a turnaround on the property.

*Circle/U-Shaped* driveways shall not be less than 12-feet in width and the inside pavement edge of the driveway shall have a minimum of a ten (10) foot offset from the right-of-way line within the property. The driveway approach radii must be at least ten (10) feet apart from each approach.

### SUBSECTION 2.15.02 | MULTI-FAMILY AND NON-RESIDENTIAL

Steel reinforced concrete driveways, providing access to multi-family or non-residential uses, shall have a minimum width of 24-feet and a maximum width of 45-feet when measured at their narrowest point near or at the property line. The minimum radius for these uses shall be 25-feet. Larger radii are encouraged. Limitations on permissible locations for these driveways are addressed in [SECTION 2.06, DRIVEWAY LOCATIONS](#). Driveway radii returns shall not extend across abutting property lines. The drive aisles for 90-degree parking shall have a minimum width of 24-feet. Drive-thru lanes are to be a minimum of 12-feet wide with a 12-foot by-pass lane.

### SUBSECTION 2.15.03 | GRADES

The change in grade between the roadway cross slope and the slope of the driveway apron is important to ensure a smooth, low speed, turning maneuver. The maximum algebraic change in grade is shown in [TABLE 2.8](#). An abrupt change in grade will cause the front bumper to drag on the surface of the street and driveway.

TABLE 2.8: DRIVEWAY GRADES AND GRADE CHANGE

TYPE	MAXIMUM GRADE	MAXIMUM ALGEBRAIC CHANGE IN GRADE
RESIDENTIAL	14%	12%
NON-RESIDENTIAL	8%	8%



When an algebraic change in grade occurs within a driveway of more than four (4) percent vertical curve will be required. The minimum recommended lengths of vertical curve for the corresponding change in grade for driveway profiles are shown in [TABLE 2.9](#). It is recommended that a two (2) foot vertical curve is provided where ever the algebraic change in grade is less than four (4) percent.

**TABLE 2.9: VERTICAL CURVE LENGTHS FOR DRIVEWAYS**

ALGEBRAIC CHANGE IN GRADE	MINIMUM LENGTH IN FEET	
	CREST CURVE	SAG CURVE
LESS THAN 4%	2	2
4% - 5.99%	5	6
6% - 8.99%	5	7
9% - 12%	6	8

All driveway profiles should be designed to accommodate a sidewalk crossing at a maximum allowable cross-slope of two (2) percent in order to meet ADA requirements. A sidewalk crossing grade of two (2) percent shall be incorporated into the driveway even if a sidewalk is not to be constructed at the same time as the driveway.

Reference [FIGURE 2.5](#) for driveway profiles on an upgrade and [FIGURE 2.6](#) for driveway profiles on a downgrade. No downgrade driveways will be allowed for new development or construction. If an existing driveway with a downgrade already exists it shall be reconstructed to conform to [FIGURE 2.6](#). All down grade driveways shall have a rise that must be equal to or above the top of curb elevation.



FIGURE 2.5: DRIVEWAY PROFILES ON AN UPGRADE

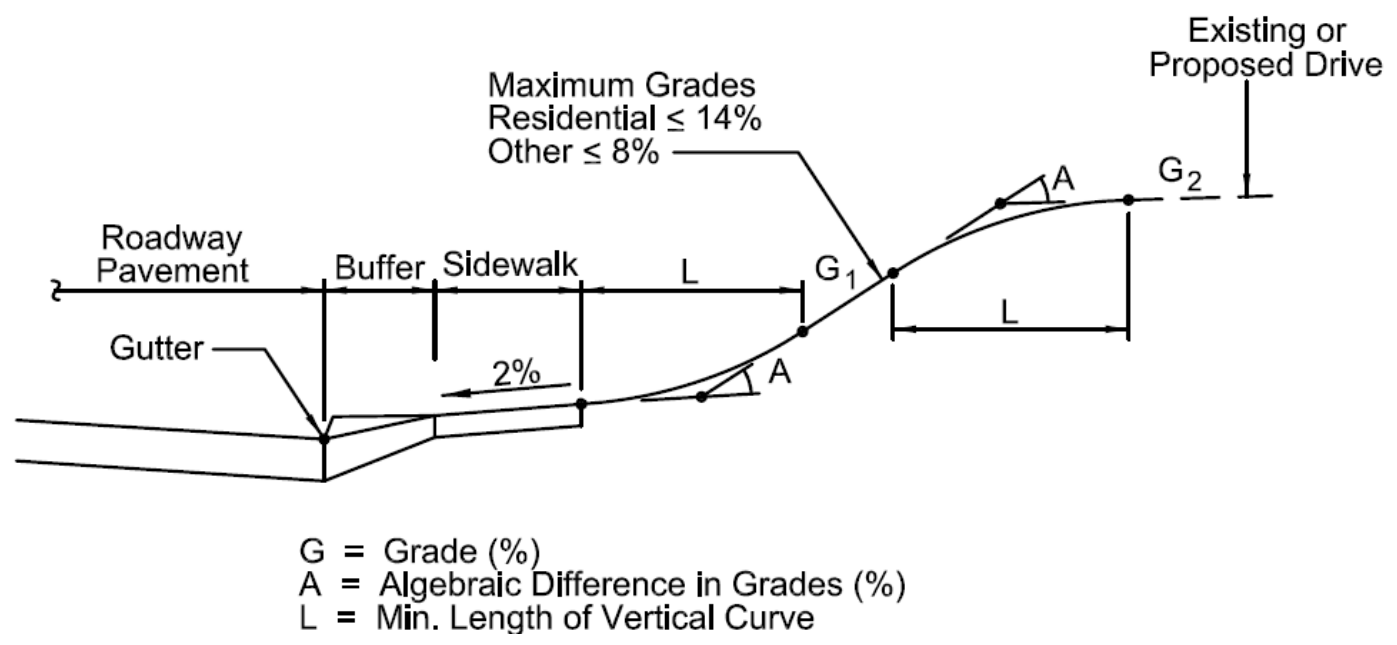
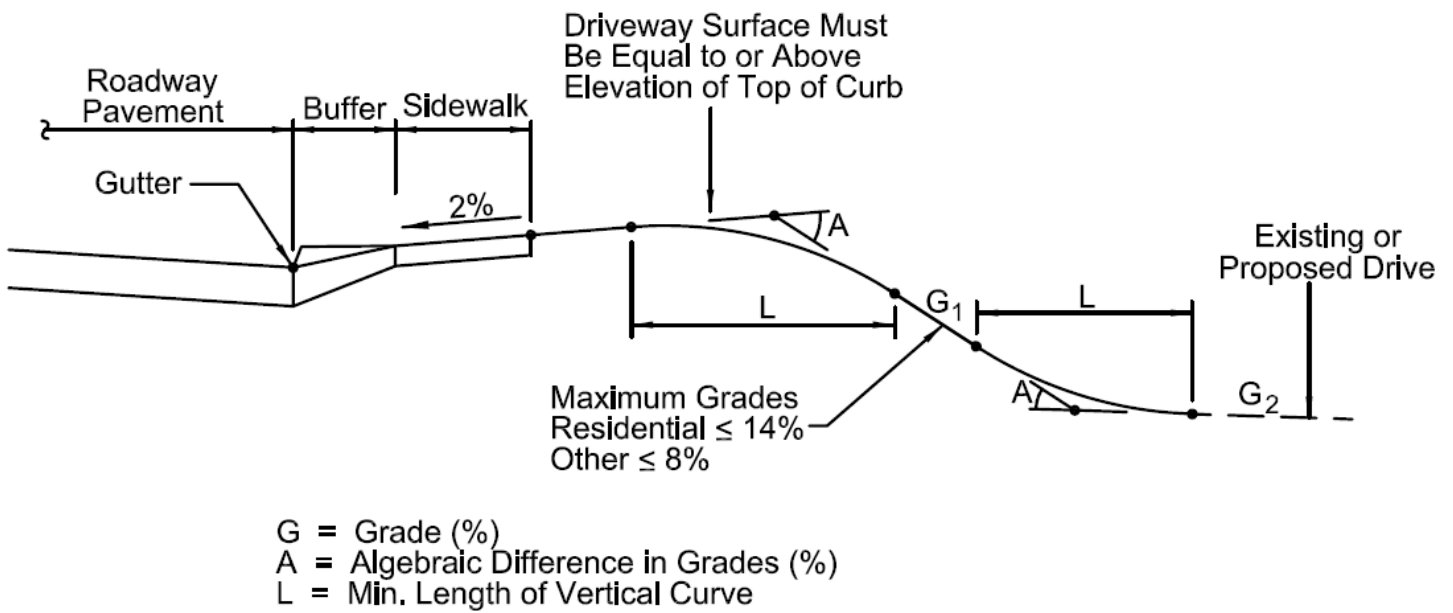


FIGURE 2.6: DRIVEWAY PROFILES ON A DOWNGRADE





## SECTION 2.16 | TRAFFIC INFORMATION AND CONTROL DEVICES

Any work disturbing traffic on City streets shall require a signed and sealed traffic control plan by a *Registered Professional Engineer* in the State of Texas. All signage in City right-of-way shall conform to the Texas Manual of Uniform Traffic Control Devices.

The developer shall be responsible for and arrange for the installation of all pavement striping, regulatory, warning, guide, and school zone signs including posts, as shown on the plans or as directed by the City. Street name signs shall be installed at each intersection. Examples of regulatory, warning, information and guide signs are as follows:

- (A) Regulatory signs shall include, but are not limited to, STOP, 4-WAY, YIELD, KEEP RIGHT and speed limit signs.
- (B) Warning signs shall include, but are not limited to, DEAD END, NO OUTLET, DIVIDED ROAD, DIP, and PAVEMENT ENDS.
- (C) Guide signals shall include, but are not limited to, street name signs, DETOUR, direction arrow and advance arrow.
- (D) Traffic striping and buttons shall be provided by the developer as shown on plans or as directed by the City.

All signage within medians, paving, sidewalks, and TXDOT right-of-way shall be break away pole bases.

### SUBSECTION 2.16.01 | REGULATORY SIGNAGE

Regulatory signs should be used only where justified by engineering judgment. All signage plans shall be reviewed and approved by the City of Rockwall Engineering Department and be designed in accordance with the principles described in the current Texas Manual on Uniform Traffic Control Devices (TMUTCD).

All street and regulatory signage shall be installed, inspected and approved, prior to final acceptance of the project. This inspection typically takes place as part of the Engineering Department's final walkthrough. Any sign related issue/issues will be noted on the projects final punch list.

- (A) A detailed street and regulatory signage plan are to be submitted to the City of Rockwall Engineering Department. All signs shall be shown in the engineering plans for review and approval. The signage plan shall be shown on a separate signage & pavement marking layout sheet or as a part of the plan & profile sheet. The plan shall identify the specific sign designation, size and location for each sign. Sign standards shall also be included in the engineering plans.
- (B) All signage installed shall comply with the current *Texas Manual on Uniform Traffic Control Devices* and the *Standard Highway Sign Designs for Texas*. The sign layout drawings shall show the color and dimensions of all sign face legend components including background color, legend color, borders, symbols, letter size and style.
- (C) The developer shall be responsible for furnishing and installing all regulatory signage, warning signage and street name signage along with all necessary sign mounts in accordance with the approved engineering plans. A sample production sign shall be submitted to the Street and Drainage Supervisor for review and approval. The sample shall be directed to the City of Rockwall Service Center located at 1600 Airport Road, Rockwall Texas 75087. The sample sign must be submitted at least ten (10) days prior to the scheduled installation date.
- (D) For a street with a cul-de-sac end, a standard *W 14-2a* shall be mounted over the street name blade, if the cul-de-sac is not clearly visible from the adjoining roadway, or is located in excess of 400 linear feet from the adjoining roadway.

### SUBSECTION 2.16.02 | STREET NAME BLADES

- (A) Street name sign blades shall be double-sided with rounded corners.
- (B) Street Name Blades shall be nine (9) inch tall flat aluminum. The blades shall be 0.080 inches thick and be a minimum of 36-inches long.
- (C) The lettering for the street signs shall be *3M 3930* high Intensity prismatic material sheeting for street, regulatory and warning signs and shall be high intensity diamond grade type III prismatic. The street sign background shall be green and the legend shall be white.
- (D) The street sign blade must incorporate the current City of Rockwall logo. The logo shall consist of white *Scotchlite Series 3930* high intensity prismatic material (*Product Code 3930*).
- (E) Block Numbers are required on all street name blades and shall be located on the top right corner of the street blade.



- (F) The lettering for the street blades shall be composed of a combination of lower-case letters with initial upper-case letters. The *Clearview TCAD-1W* font shall be used. The lettering shall be composed of initial upper-case letters of at least six (6) inches in height and lower-case letters of at least 4½-inches in height. For supplementary lettering to indicate the type of street (*e.g. Street, Avenue or Road*) shall be composed of initial upper-case letters at least three (3) inches in height and lower-case letters at least 2¼-inches in height. Abbreviations may be used (*e.g. St., Ave., or Rd.*) except the street name itself. The supplementary lettering shall be located at the lower right corner of the street blade, under the block number.
- (G) The street blade sign shall consist of green *Scotchlite 3930* high intensity prismatic material background (*Product Code 3937*) and white *Scotchlite 3930* high intensity prismatic material for the lettering (*Product Code 3930*). The background sheeting shall be white *3M 390* high intensity prismatic material. The background material shall be applied to the full width and height of the sign blank leaving no metal exposed. The background material shall be one continuous piece of material. Patching of background material is not allowed and any sign with patching material of any type will be rejected by the City.

#### ALTERNATIVE OPTION

As an alternative, the foreground color may be green transparent *Scotchlite ElectroCut1177 film* (*i.e. E.C. film*). Lettering shall be cut out and removed producing a single continuous piece of green transparent film material.

- (H) All traffic signals shall have backlit name signage per City requirements.

#### SUBSECTION 2.16.03 | STANDARD STREET SIGN POLE AND FIXTURES

- (A) Standard Street Sign Post. Standard street sign posts shall be 12-foot long, and a minimum 2¾-inch galvanized steel round post with a minimum of 60 mil wall thickness.
- (B) Standard Post Installation Depth. A sign post shall be installed into solid ground to a minimum depth of 24-inches and anchored with a minimum of 60 pounds of concrete.
- (C) Standard Post Bracket. Standard post brackets shall be 18-inches cast aluminum round post bracket street sign mount for bottom street blade.
- (D) Standard Top Crossing Bracket. Standard top crossing brackets shall be 12-inch cast aluminum top crossing street sign bracket mount for top street blade.
- (E) Standard Mounting Bracket Assemblies. Standard mounting bracket assemblies shall be 2¼-inch diameter aluminum round post interlocking bracket with two (2) per pole.

#### SUBSECTION 2.16.04 | DECORATIVE SIGN POLES AND FIXTURES

The City of Rockwall will allow the installation of decorative signs and posts or street lights or other non-standard items by *Developers/Homeowners Associations (HOAs)* on a case-by-case basis provided that their installation does not result in an adverse impact to the public safety and that there is no cost to the City for installation or maintenance. Residential developer requesting such installations will be required to give the recorded documentation of an incorporated Homeowner's Association (HOA) to the City. The City of Rockwall maintains only standard street and regulatory signs/post/lights installed on public streets within its designated rights-of-way. The City of Rockwall does not maintain decorative sign poles, fixtures and light fixtures installed by developers or HOA.

If the developer elects to install non-standard decorative signs, sign poles, light poles and fixtures, the designated HOA must enter into a maintenance agreement with the City covering the hold harmless provisions. These provisions shall be noted on the approved final plat for the subdivision. The platted maintenance provisions will serve as the agreement and applies to all non-standard decorative signs, poles/post, hardware, lights, or any other attachments. The City of Rockwall has no maintenance or other responsibility to these items. The ownership and maintenance of all such signs, poles and fixtures become the maintenance responsibility of the designated HOA.

#### DECORATIVE SIGN POLE/FIXTURE SUBMITTALS

A detail of the decorative sign poles, pole fixtures and base mounting shall be included with the submittal of the civil engineering construction plans. The submittal shall also include a street/site plan indicating the location and identification of all proposed signage and post to scale.

#### HOMEOWNER'S ASSOCIATIONS (HOA) MAINTENANCE - RESPONSIBILITIES AND PROVISIONS



- (A) The HOA is responsible for maintaining all non-standard decorative signs, poles/post, hardware, attachments or other approved non-standard items under this agreement. The City of Rockwall has no maintenance or other responsibility to these items. The City of Rockwall and the HOA agree the Association will bear any and all maintenance cost related to the said improvements. The City has the statutory authority to install and maintain traffic control devices for vehicular traffic on public streets/roads within the city limits of the City of Rockwall, Texas. This agreement in no way constitutes a change in that authority and does not constitute any delegation of this authority to the Association.
- (B) The City of Rockwall reserves the right to install temporary replacement signs using standard sign post mounting or alternate temporary mounting when decorative sign posts and signs are damaged. Routine maintenance/replacement of damaged signs, posts and any sign mounting backboard/trim/hardware or other fixtures is the sole responsibility of the HOA and must be repaired within four (4) weeks of reporting to the HOA.
- (C) The City of Rockwall will not handle, store or be responsible for any decorative non-standard sign, post or associated fixtures installed under this agreement.
- (D) All signs (regulatory and warning) shall be in conformance with the *Texas Manual on Uniform Traffic Control Devices (Texas MUTCD)* and the *Standard Highway Sign Designs for Texas*.
- (E) Sign posts must be of sufficient height to mount the sign in conformance with the current (*Texas MUTCD*) requirements. Most typical installations require a vertical clearance of seven (7) feet from the bottom edge of the sign to the ground surface. Overhead signs must conform to all required standards.
- (F) Signs/posts must be installed in locations as provided in the approved engineering/construction plans or as otherwise approved by the City of Rockwall. On occasion, it may be necessary to re-locate signage/poles based on engineering judgment, study or when otherwise deemed necessary by the City.
- (G) The City of Rockwall reserves the right to approve or disapprove any sign/pole design and/or location. The City of Rockwall must approve the color of signposts and any requested sign mounting/trim.

#### SUBSECTION 2.16.05 | MISCELLANEOUS

Street address markers shall be installed for each lot in the subdivision. The markers shall be located at the center of the lot on the face of the curbs. The address markers shall have a deep green background with reflective white numbers. The number size shall be four (4) inches in height. The background of the address marker shall be 18-inches in length and from the top of curb to the gutter flow line. The address marker shall show the full numerical portion of the address of the lot.

All non-street signage for developments are required to have a separate permit from the building department. Signs, including any overhangs, are not allowed in any rights-of-way and/or easements. Location of any signage is not approved on engineering plans.

#### SECTION 2.17 | TEMPORARY TRAFFIC CONTROL

When the normal function of the roadway is suspended through closure of any portion of the right-of-way, temporary construction work zone traffic control devices shall be installed to effectively guide the motoring public through the area. Consideration for road user safety, worker safety, and the efficiency of road user flow is an integral element of every traffic control zone. No roadway may be completely closed without approval of the City Engineer and City Council.

All traffic control plans shall be prepared and submitted to the Engineering Department in accordance with the standards identified in *Part VI* of the most recent edition of the *TMUTCD*. Lane closures will not occur on roadways without an approved traffic control plan. Traffic control plans shall be required on all roadways as determined by the City Engineer or the designated representative. All traffic control plans must be prepared and signed and sealed by an individual that is licensed as a professional engineer in the State of Texas. All traffic control plans and copies of work zone certification must be submitted for review and approval a minimum of three (3) weeks prior to the anticipated temporary traffic control. The contractor executing the traffic control plan shall notify all affected property owners, emergency services, school district, mail service, trash service, etc. at least two (2) weeks prior to any the closures.

Any deviation from an approved traffic control plan must be reviewed by the City Engineer or the designated representative. If an approved traffic control plan is not adhered to, the contractor will first receive a verbal warning and be required to correct the problem immediately. If the deviation is not corrected within twenty-four (24) hours, all construction work will be suspended, the lane closure will be removed, and the roadway opened to traffic.



All temporary traffic control devices shall be removed as soon as practical when they are no longer needed. When work is suspended for short periods of time at the end of the workday, temporary traffic control devices that are no longer appropriate shall be removed or covered. The first violation of this provision will result in a verbal warning to the construction foreman. Subsequent violations will result in suspension of all work at the job site for a minimum of 48-hours. All contractors working on City funded projects will be charged one working day for each 24-hour closure.

Lane closures on any major or minor arterial will not be permitted between the hours of 6:00 AM to 9:00 AM and 4:00 PM to 7:00 PM. Where lane closures are needed in a school area, they will not be permitted during peak hours of 7:00 AM to 9:00 AM and 3:00 PM to 5:00 PM. Closures may be adjusted according to the actual start-finish times of the school with approval by the City Engineer. The first violation of this provision will result in a verbal warning to the construction foreman. Subsequent violations will result in suspension of all work at the job site for a minimum of 48-hours. All contractors working on City funded projects will be charged one working day for each 24-hour closure of a roadway whether they are working or not.

#### SECTION 2.18 | SECTION 1.18 | STREET LIGHTING

All developments shall provide streetlights along public roadways. In general, lights should be located at street intersections and at intervals no greater than 400-feet apart. Street lights shall be centered 1½-feet off the back of curb. Nonstandard street lights may be allowed by City Council. Nonstandard street lights must be maintained by HOA or the adjacent property owner that requested the nonstandard light. Maintenance requirement shall be included on the plat. The City shall not be responsible for the replacement of nonstandard lights.

#### SECTION 2.19 | BARRIER FREE RAMPS

Barrier free ramps shall be provided in all commercial areas and in residential areas which have sidewalks. Ramps shall be located to provide access in accordance with the standards set by the *Texas Department of Licensing and Regulation (TDLR)* at all pedestrian sidewalks. Laydown curbs and ramps shall be constructed at all street intersections and non-single family residential driveways whether or not sidewalks are being installed. Laydown curbs and ramps shall be constructed by the developer. Barrier free ramps shall have truncated dome plates in the color approved by the City. No truncated dome pavers or ridges allowed. Directional ramps should be used. Blended ramps should only be used when directional ramps are not feasible.

#### SECTION 2.20 | OFF-STREET PARKING, LOADING, AND STORAGE AREAS

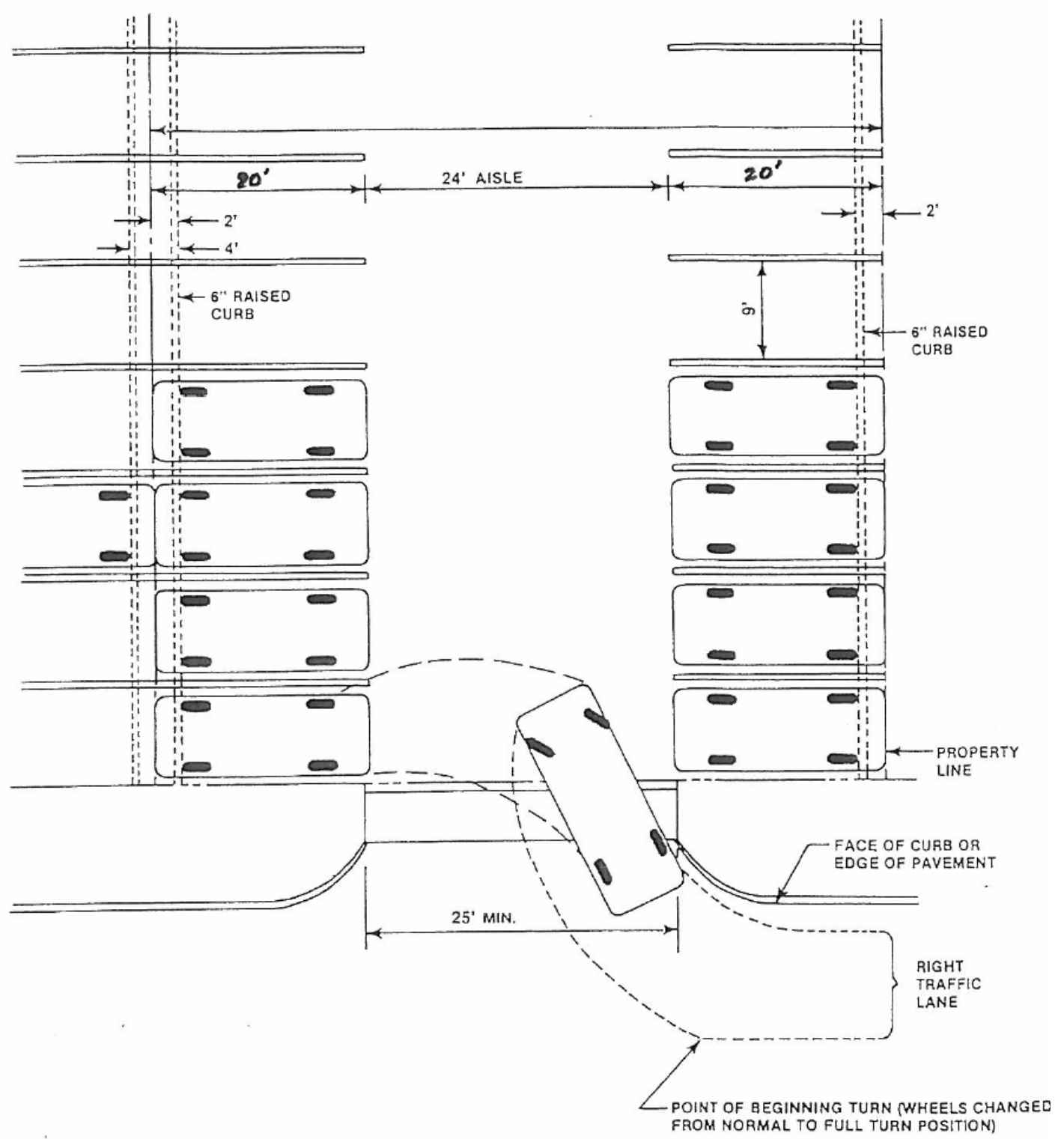
All parking areas, parking spaces, loading areas, and storage areas shall be designed and constructed of steel reinforced concrete in accordance with the following requirements:

- (A) All parking areas and spaces shall be designed and constructed of steel reinforced concrete so as to have free ingress and egress at all times.
- (B) No parking space or parking area shall be designed so as to require a vehicle to back into a public street or across a public sidewalk, except in the case of one (1) and two (2) family dwelling units.
- (C) Minimum Dimensions for Off-Street Parking:
  - (1) 90° Parking (FIGURE 2.7 and FIGURE 2.8). All parking spaces shall be a minimum of nine (9) feet in width. Each parking space adjacent to a building or future building shall not be less than 20-feet in length. Dual head in parking spaces should be a minimum of 20-feet in length. Maneuvering space shall not be less than 24-feet. Existing parking areas may remain the same dimensions when reconstructed, but new/additional parking must meet above dimensions.
  - (2) 60° Angle Parking (FIGURE 2.9 and FIGURE 2.10). Each parking space shall be not less than nine (9) feet wide perpendicular to the parking angle nor less than 20.10-feet in length when measured at right angles to the building or parking line. Maneuvering space shall be not less than 14½-feet for one (1) way traffic or 24-feet for two (2) way traffic perpendicular to the building or parking line.
  - (3) 45° Angle Parking (FIGURE 2.11 and FIGURE 2.12). Each parking space shall not be less than nine (9) feet wide perpendicular to the parking angle nor less than 19-feet in length when measured at right angles to the building or parking line. Maneuvering space shall be not less than 12-feet for one (1) way traffic or 24-feet for two (2) way traffic perpendicular to the building or parking line.
  - (4) Parallel Parking. Each parking space shall not be less than nine (9) feet in width and 22-feet in length. Maneuvering space will not be less than 24-feet.



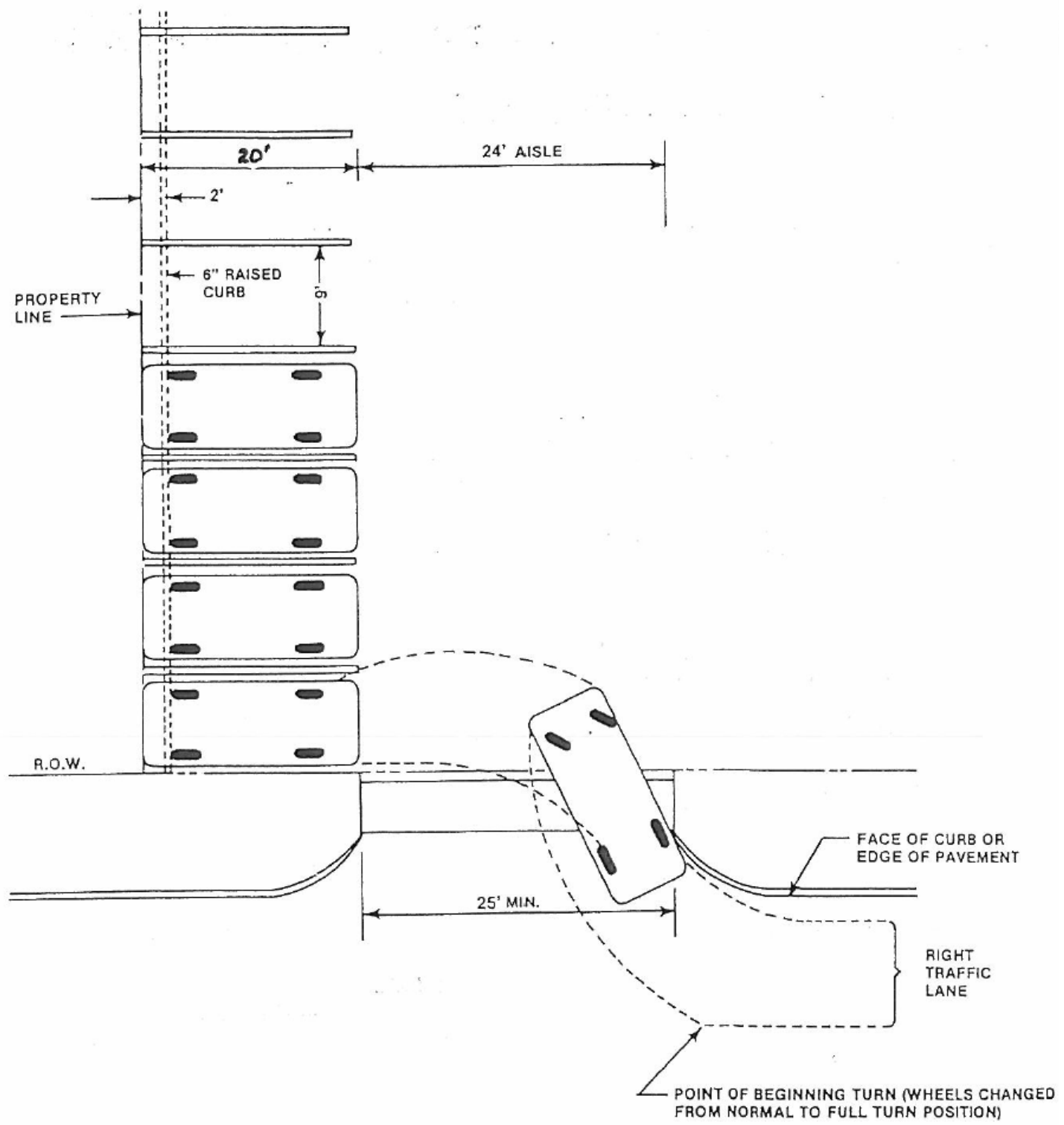
- (5) Handicap Space Parking. Where handicapped parking is required or installed, the design shall be as in [FIGURE 2.13](#).
- (6) When off-street parking facilities are provided in excess of minimum amounts herein specified, or when off-street parking facilities are provided, but not required by this *Chapter*, said off-street parking facilities shall comply with the minimum requirements for parking and maneuvering space herein specified.
- (7) Each parking space/stall shall be striped to the minimum dimension detailed out above in this section.
- (8) No dead-end parking shall be allowed for more than six (6) parking spaces without a minimum turnaround of 15-feet wide by 64-feet long or a cul-de-sac which shall be striped and signed as *No Parking*. If there are less than six (6) parking spaces, a 24-foot by 15-foot turnaround area will be allowed and shall be striped and signed as *No Parking*.

FIGURE 2.7: 90° PARKING (DOUBLE ROW)



90°

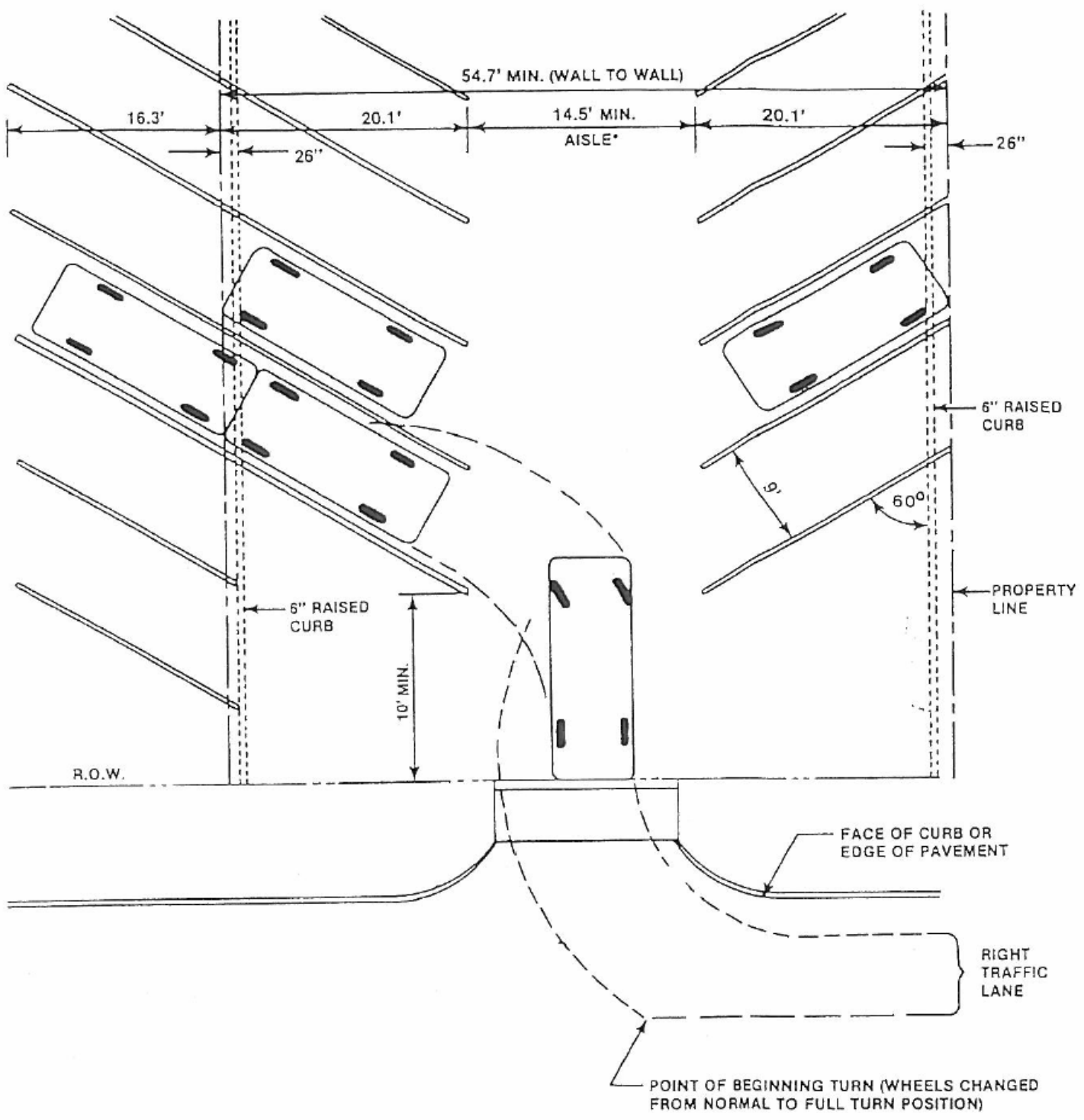
FIGURE 2.8: 90° PARKING (SINGLE ROW)



# 90°



FIGURE 2.9: 60° PARKING (DOUBLE ROW)



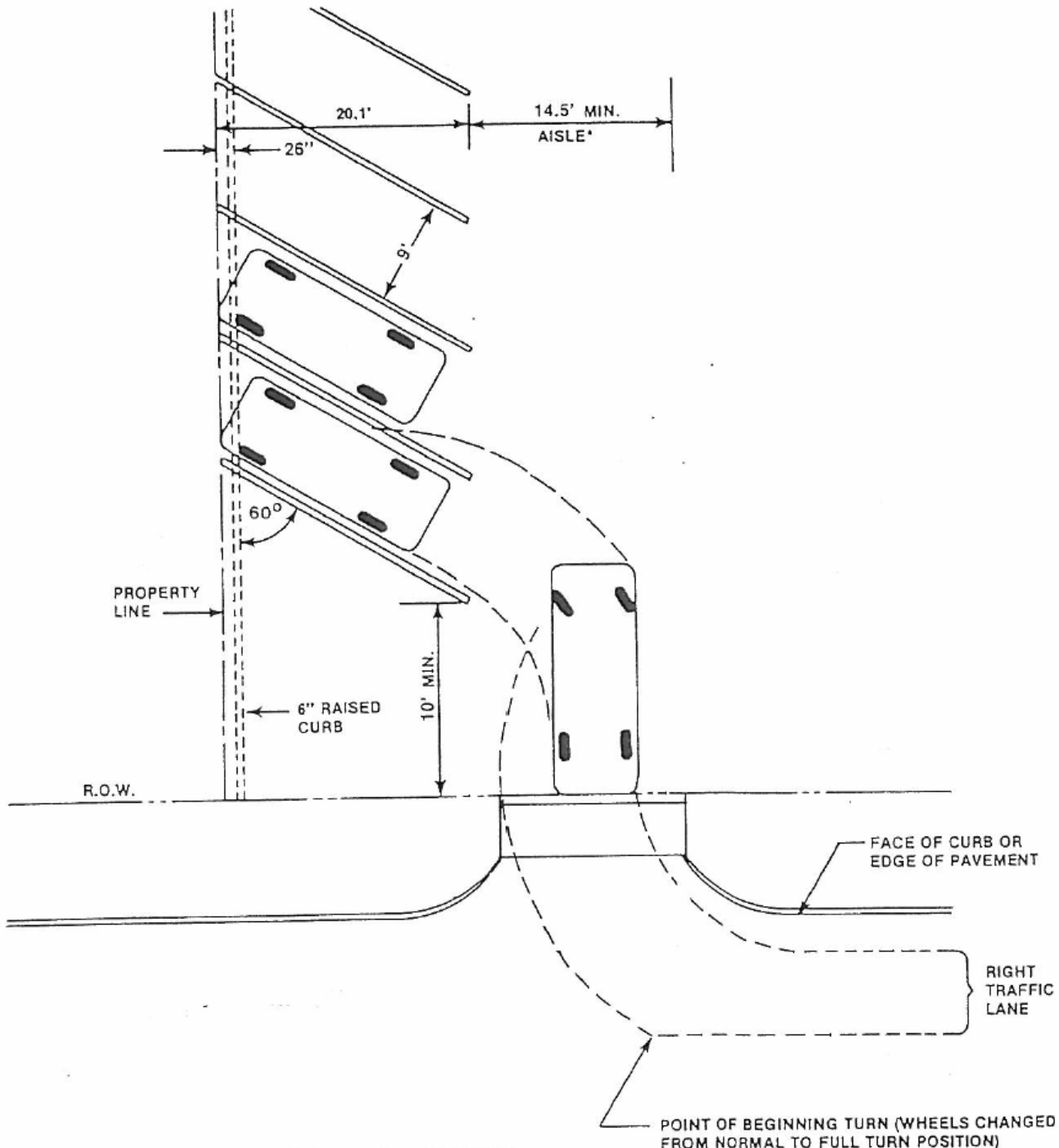
\* Aisle width shown is the minimum for one-way traffic. For ease of operation and for long rows of parking, widths should be increased approximately 5'

For two-way traffic, the aisle width must be increased to 22.0' (Clear distance of 24.3')

# 60°



FIGURE 2.10: 60° PARKING (SINGLE ROW)



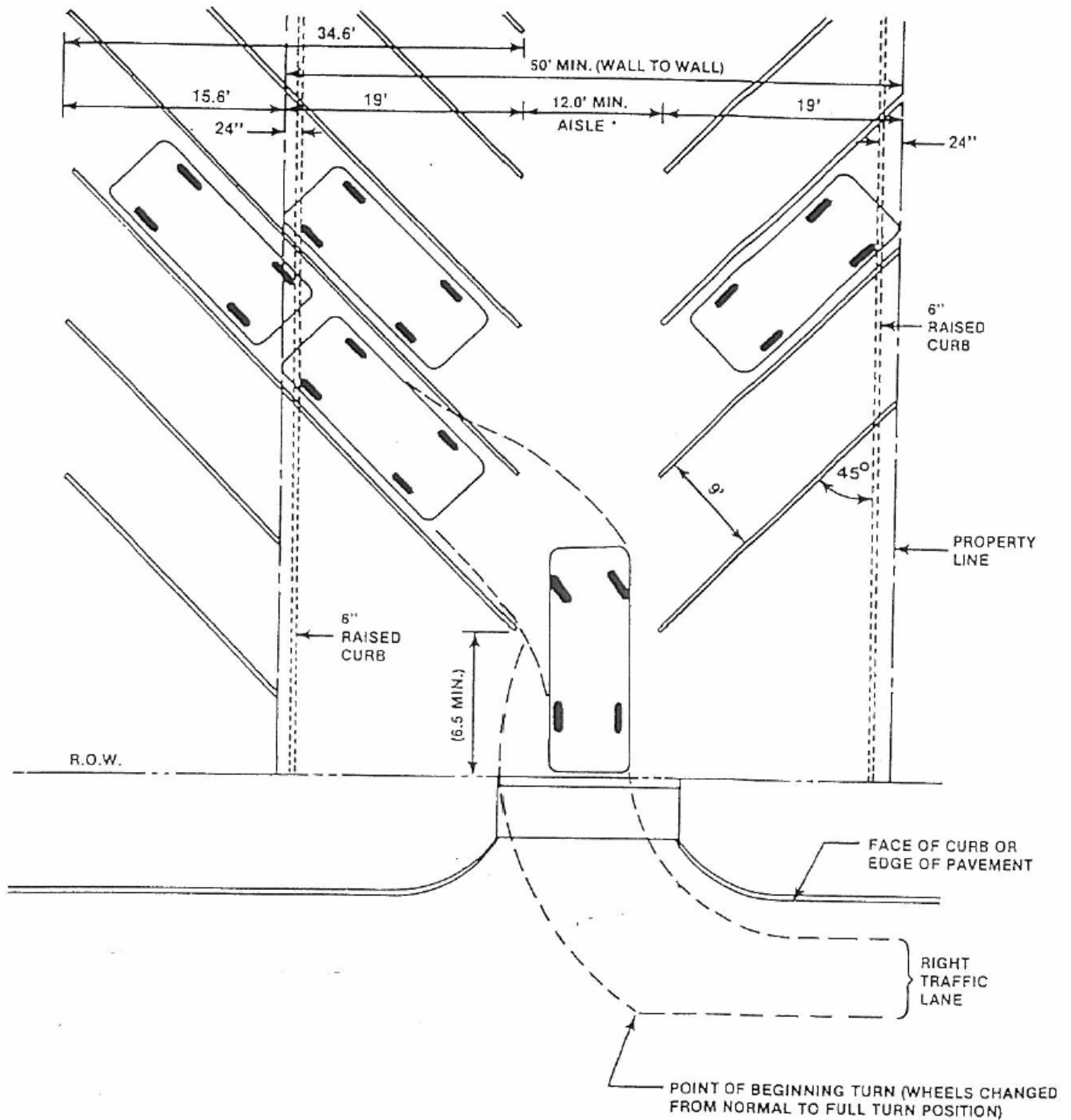
\* Aisle width shown is the minimum for one-way traffic. For ease of operation and for long rows of parking, widths should be increased approximately 5'

For two-way traffic, the aisle width must be increased to 22.0' (Clear distance of 24.3')

# 60°



FIGURE 2.11: 45° PARKING (DOUBLE ROW)



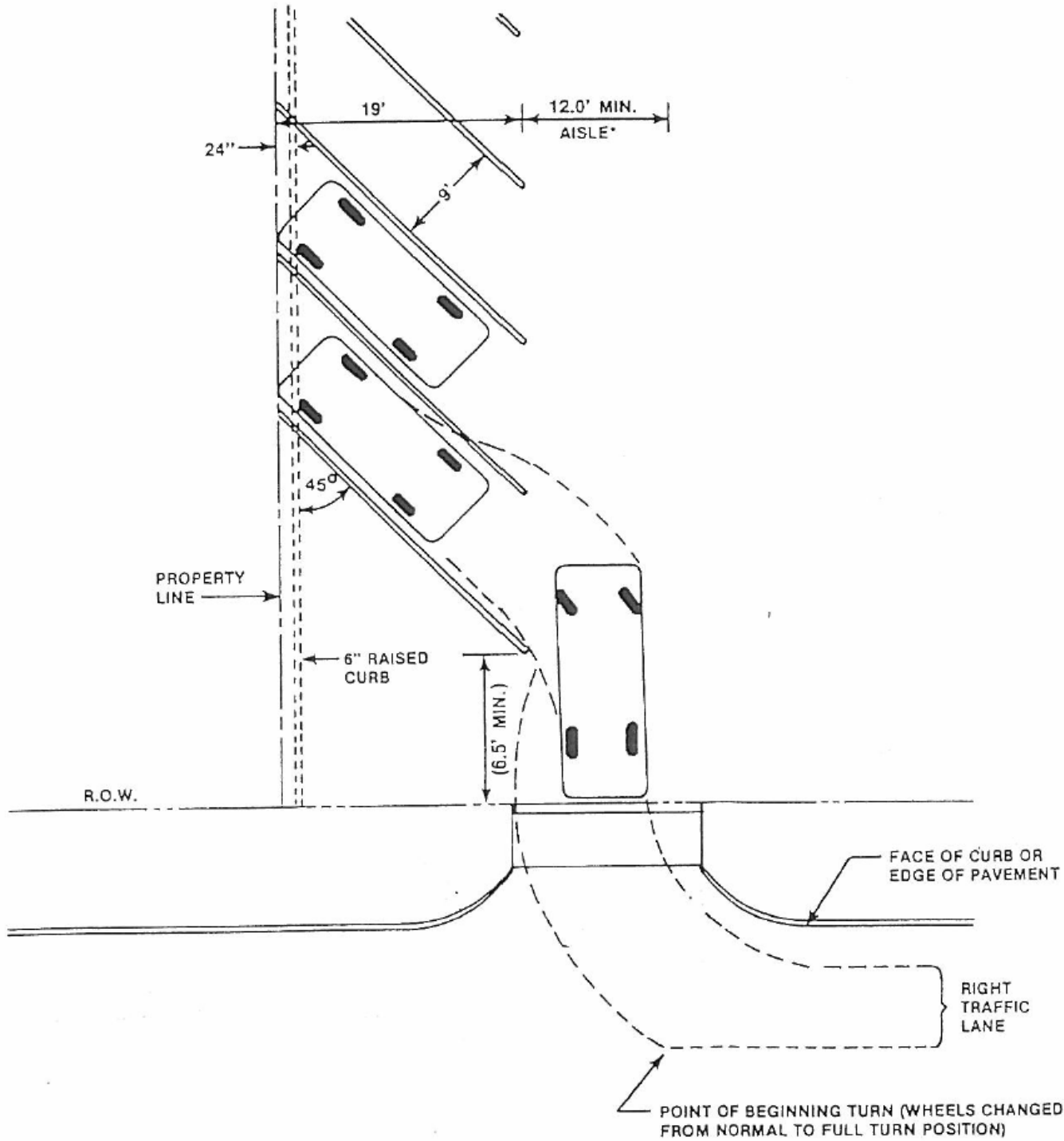
\* Aisle width shown is the minimum for one-way traffic. For ease of operation and for long rows of parking, width should be increased approximately 5'

For two-way traffic the aisle width must be increased to 21'  
(Clear distance of 24.2')

# 45°



FIGURE 2.12: 45° PARKING (SINGLE ROW)

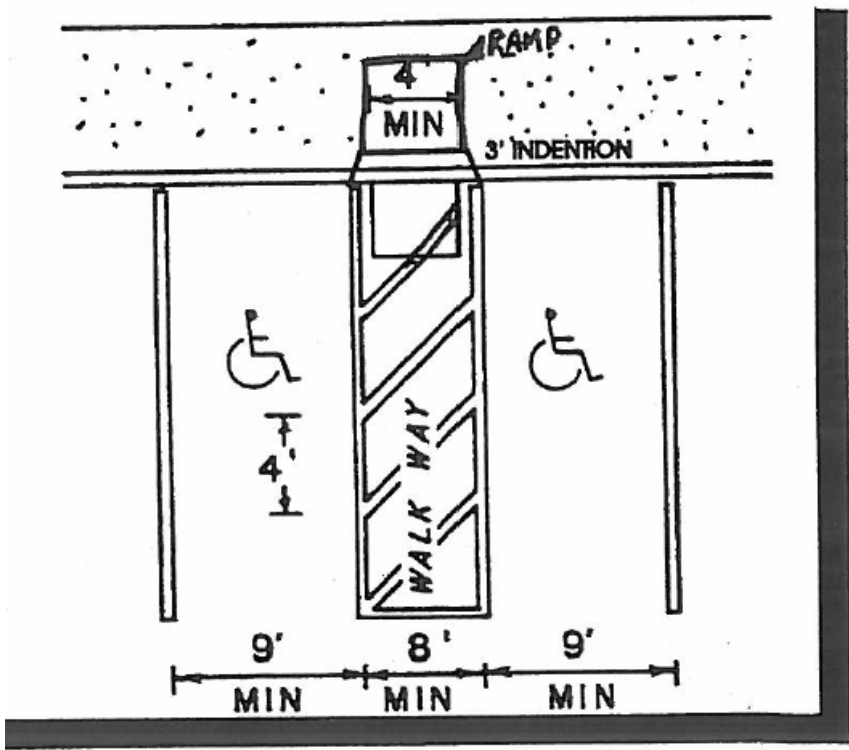


\* Aisle width shown is the minimum for one-way traffic. For ease of operation and for long rows of parking, widths should be increased approximately 5'

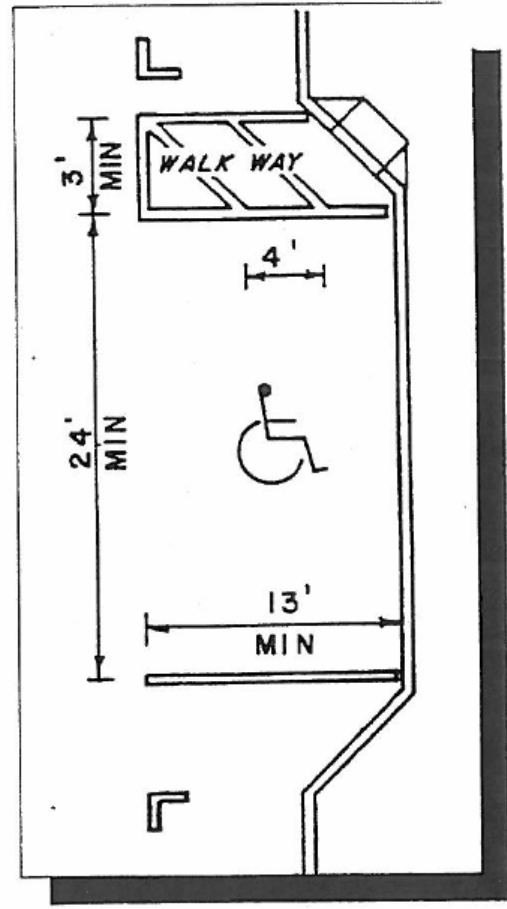
For two-way traffic, the aisle width must be increased to 21.0' (Clear distance of 24.2')

# 45°

FIGURE 2.13: HANDICAP SPACE PARKING



**HANDICAPPED PARKING STANDARDS**  
Head-in or Angle parking Dimensions



**HANDICAPPED PARKING STANDARDS**  
Parallel parking Dimensions



(D) Paving Standards.

- (1) Unless otherwise approved by the City Council or as specified in these standards, all parking lots, loading areas, and storage areas shall be paved with steel reinforced concrete and designed according to City standards and specifications. The parking spaces must be clearly marked by approved paint, buttons or other material.
- (2) All driveway approaches shall be constructed of steel reinforced concrete in the same strength, thickness, and reinforcing as the adjacent street and shall be curbed per City standards.
- (3) All parking lot pavement and drive aisles shall be steel reinforced concrete except for existing asphalt parking lots being rehabilitated. A steel reinforced concrete or asphalt pavement (*rehabilitated parking lots*) design shall be provided to the City Engineer for review and approval.
- (4) Industrial and commercial parking lot pavement shall be steel reinforced concrete and designed by a Professional Engineer. Pavement design shall be submitted to the City for approval.
- (5) The pavement within designated or non-designated loading and storage areas shall be designed and constructed to carry the additional loading of merchandise, goods, sanitation pick-up, etc., in order to prevent any unnecessary failure in the pavement itself. The pavement design shall be included in the engineering construction plans and specifications and submitted to the City Engineer for approval. The pavement design shall be designed by a Geotechnical Engineer constructed of steel reinforced concrete.
- (6) Fire lane shall have a maximum running slope of ten (10) percent and a cross slope of five (5) percent. A vertical curve is required for grade breaks greater than one (1) percent.
- (7) All proposed paving connections to existing concrete paving require a longitudinal butt joint connection.

(E) If a portion of an existing street is removed for construction, except for a proposed driveway connection, at a minimum the entire concrete panel must be removed and replaced with the same strength steel reinforced concrete and one (1) inch thicker than the existing thickness. Additional roadway panels may be required to be removed and replaced due to condition and ability to connect to.

(F) All entrances or exits in a parking lot shall have a minimum curb return radius of 30-feet from the beginning point of any corner radius.

(G) All entrances or exits in a parking lot shall be a minimum of 24-feet and a maximum of 45-feet in width, unless one (1) way, in which case they shall both be a minimum of 12-feet, or as approved by the City Council.

(H) No parking areas or parking spaces shall be allowed to pave over or utilize public right-of-way, with the exception of approved entrances and exits, unless the City Council grants an exception and/or a facilities agreement.

(I) All multi-family and commercial parking areas and parking spaces shall be designed and constructed to protect adjacent residences from the direct glare of headlights of vehicles using the parking area.

(J) No City street curb, alley, or street pavement may be cut without a permit from the City.

(K) All fire lanes are to be maintained, repaired, and replaced by the property owner.

(L) Rollover/mountable curbs are not allowed on any roadway.

(M) If required, the contractor shall submit a traffic control design to the City of Rockwall Engineering Department prepared, signed, and sealed by a registered professional engineer prior to beginning of construction. The contractor shall provide signs and barricades in construction areas and comply with the Texas Department of Transportation standard of work zone traffic control. Employees exposed to public vehicular traffic, shall be provided with and wear warning vest or other suitable garments marked with or made of reflective or high visibility material. The contractor shall provide flagman when working inside an active street right-of-way where necessary.

## SECTION 2.21 | TRAFFIC IMPACT ANALYSIS (TIA) AND MITIGATION

### SUBSECTION 2.21.01 | PURPOSE

The purpose of a Traffic Impact Analysis (TIA) is to assess the effects of specific development activity on the existing and planned thoroughfare system. Development activity may include, but is not limited to, rezoning, preliminary site plans, site plans, preliminary plats, driveway permits, Certificates of Occupancy (CO), and Master Thoroughfare Plan amendments.



### SUBSECTION 2.21.02 | DETERMINATION OF APPLICABILITY

The need for a TIA shall be determined by the City based upon the results and recommendation from a pre-development meeting, the Planning and Zoning Commission, or the City Council. It shall be the responsibility of the applicant to demonstrate that a TIA may not be required. If a TIA is required, the level of effort for a TIA submission shall be determined based on the criteria set forth in [TABLE 2.10](#).

### SUBSECTION 2.21.03 | APPLICABILITY OF TIA REQUIREMENTS

- (A) Zoning, Site Plan and Platting. These TIA requirements shall apply to all requests for land use changes which will establish a land use that is deemed to be more intense than the land use depicted on the Land Use Plan contained within the Comprehensive Plan for a particular property. Applicable requests will also include zoning, site plan, and platting cases, Master Thoroughfare Plan amendments, and/or where deemed necessary by the City Engineer, Director of Planning and Zoning, the Planning and Zoning Commission, or the City Council. Special circumstances -- *including but not limited to development with no case history* -- may also require a TIA.
- (B) Development. These TIA requirements shall apply to all development requests for land uses -- *except single-family residential* --, which will generate over 100 total trips during the AM or PM peak hour. Applicable development requests include all development related applications. Special cases, in which site generated peak hour trip activity is different from that of the adjacent street (weekdays 7:00 AM - 9:00 AM and 4:00 PM - 6:00 PM), may require an additional separate analysis. Such circumstances may include, but are not limited to, the establishment of commercial/retail, entertainment or institutional developments or activity. The TIA requirement may be waived for a development if a TIA was performed previously with the zoning request and the conditions listed in the report are still current.
- (C) Single-Family Residential Exception. A TIA for single-family residential development will not be required if the development contains fewer than six (6) dwelling units unless special circumstances exist, as determined by the City Engineer and/or Director of Planning and Zoning. These special circumstances may include, but are not limited to, impacts to other residential developments from cut-through traffic, inadequate site accessibility, the construction or delay of construction of a thoroughfare prior to or after the anticipated date of construction resulting from a proposed development, or the street or access system not being anticipated to accommodate the expected traffic generation.
- (D) Depending upon the specific site characteristics of the proposed development, one (1) or more of the following elements may also be required as part of the TIA: [1] an accident analysis, [2] sight distance analysis, [3] traffic simulation, [4] traffic signal warrant analysis, [5] queuing analysis, [6] right/left-turn lane analysis, [7] access spacing analysis, [8] link capacity analysis, and/or traffic [9] circulation plan.



**TABLE 2.10: CRITERIA FOR DETERMINING TIA STUDY REQUIREMENTS**

ANALYSIS CATEGORY	CRITERIA	TIA ANALYSIS PERIODS <sup>1</sup>	STUDY AREA <sup>4</sup>
I	PROJECTED SITE GENERATED ADT OF 750		
	<b>OR</b>		
	PROJECTED SITE GENERATED PEAK HOUR TRIPS OF 100 PER HOUR	(1) EXISTING YEAR	(1) ALL DRIVEWAY ACCESS POINTS, ADJACENT ROADWAYS, AND MAJOR INTERSECTIONS
	<b>AND</b>	(2) OPENING YEAR <sup>2</sup>	(2) ALL SIGNALIZED INTERSECTIONS ON EACH STREET SERVING THE SITE WITHIN ¼ MILE OF THE SITE BOUNDARY
	NO SIGNIFICANT MODIFICATION OF TRAFFIC SIGNALS OR ROADWAY GEOMETRY PROPOSED		
II	PROJECTED SITE GENERATED ADT OF 751-2,000		
	<b>OR</b>		
	PROJECTED SITE GENERATED PEAK HOUR TRIPS OF 101-250 PER HOUR OR INSTALLATION	(1) EXISTING YEAR	(1) ALL DRIVEWAY ACCESS POINTS, ADJACENT ROADWAYS, AND MAJOR INTERSECTIONS
	<b>OR</b>	(2) OPENING YEAR <sup>3</sup>	(2) ALL SIGNALIZED INTERSECTIONS AND MAJOR UNSIGNALIZED INTERSECTIONS ON EACH STREET SERVING THE SITE WITHIN ½ MILE OF THE SITE BOUNDARY
	MODIFICATION A TRAFFIC SIGNAL OR ROADWAY GEOMETRY PROPOSED, REGARDLESS OF PROJECT SIZE	(3) FIVE YEARS AFTER COMPLETION	
III	PROJECTED SITE GENERATED ADT EXCEEDS 2,000		
	<b>OR</b>		
	PROJECTED SITE GENERATED PEAK HOUR TRIPS EXCEEDS 250 PER HOUR	(1) EXISTING YEAR	(1) ALL DRIVEWAY ACCESS POINTS, ADJACENT ROADWAYS, AND MAJOR INTERSECTIONS
	<b>OR</b>	(2) OPENING YEAR <sup>3</sup>	(2) ALL SIGNALIZED INTERSECTIONS AND MAJOR UNSIGNALIZED INTERSECTIONS ON EACH STREET SERVING THE SITE WITHIN 1 MILE OF THE SITE BOUNDARY
	INSTALLATION OR MODIFICATION OF TWO OR MORE TRAFFIC SIGNALS, ADDITION OF TRAVEL LANES, OR MODIFICATION OF INTERCHANGE PROPOSED, REGARDLESS OF PROJECT SIZE	(3) FIVE YEARS AFTER COMPLETION	

**NOTES:**

- <sup>1</sup>: ANALYSIS PERIODS SHALL INCLUDE BUILD AND NO-BUILD SCENARIOS. ASSUME FULL OCCUPANCY FOR EACH PHASE AS THEY OPEN.
- <sup>2</sup>: ASSUME FULL BUILD-OUT AND OCCUPANCY.
- <sup>3</sup>: ADDITIONAL ANALYSIS PERIODS RELATING TO COMPLETION OF INTERIM PHASES MAY BE CONSIDERED FOR PHASED DEVELOPMENTS TO SUPPORT DELAYING CONSTRUCTION OF PLANNED MITIGATIONS UNTIL FUTURE PHASES ARE CONSTRUCTED. ASSUME FULL BUILD-OUT AND OCCUPANCY OF EACH PARTICULAR PHASE
- <sup>4</sup>: THE CITY MAY ENLARGE OR REDUCE THE STUDY AREA DEPENDING ON THE PROJECT. THIS IS MEANT TO PROVIDE GENERAL GUIDANCE TO THE DEVELOPER. LAND USES WITHIN THE STUDY AREA SHOULD INCLUDE RECENTLY APPROVED OR PENDING DEVELOPMENT ADJACENT TO THE SITE.



**SUBSECTION 2.21.04 | REQUIREMENTS FOR TIA UPDATES**

A TIA shall be updated when the time or circumstances of the original study fall within the parameters presented in [TABLE 2.11](#). The applicant is responsible for the preparation and submittal of appropriate documentation in order for City staff to process the zoning or development application. A TIA for site development requests must be updated if two (2) years have passed since the original submittal and/or approval, or if existing or assumed conditions have changed within the defined study area.

**TABLE 2.11: CRITERIA FOR DETERMINING TIA UPDATE REQUIREMENTS**

ORIGINAL TIA REPORT WAS BASED ON ...	CHANGES TO THE ORIGINALLY PROPOSED DEVELOPMENT ...	
	ACCESS CHANGED <sup>1</sup> <b>OR</b> TRIP GENERATION INCREASED BY MORE THAN 10%	ACCESS NOT CHANGED <b>AND</b> TRIP GENERATION INCREASED BY LESS THAN 10%
ZONING; OR PRELIMINARY SITE PLAN OR SITE PLAN THAT IS LESS THAN TWO (2) YEARS OLD	LETTER AMENDMENT REQUIRED: IDENTIFY AND REPORT ONLY ANALYSIS CONDITIONS THAT HAVE CHANGED	LETTER DOCUMENTING CHANGE (NO ANALYSIS IS REQUIRED)
PRELIMINARY SITE PLAN OR SITE PLAN THAT IS MORE THAN TWO (2) YEARS OLD	PREPARE NEW STUDY. MUST MEET ALL CURRENT TIA REQUIREMENTS	PREPARE NEW STUDY. MUST MEET ALL CURRENT TIA REQUIREMENTS.

**NOTES:**

<sup>1</sup>: CHANGED ACCESS INCLUDES PROPOSED NEW ACCESS OR REFINEMENT OF GENERAL ACCESS LOCATIONS NOT SPECIFICALLY ADDRESSED IN ORIGINAL PROPOSED DEVELOPMENT.

**SUBSECTION 2.21.05 | FUNDING RESOURCES**

- (A) The Developer will be responsible for all costs related to the design, construction and implementation of all recommended mitigations that have been accepted and deemed required by the City Engineer, not otherwise funded by other government agencies. The City Engineer may require consideration of alternative mitigation options that may not have been included in the TIA.
- (B) The TIA may take into account the city/state/county approved traffic improvements with dedicated funding. Prior to issuance of a Certificate of Occupancy (CO) permit or Engineering Acceptance Letter, the Developer shall complete any required traffic improvements approved by the City as a result of the development which have not been funded or otherwise completed by government agencies. The City may approve delaying the construction of required improvements based on the development's phasing.

**SUBSECTION 2.21.06 | RESPONSIBILITY OF TIA PREPARATION AND REVIEW**

- (A) A TIA shall be prepared in accordance with all of the guidelines in this section and submitted in accordance with the Development Review Schedule set by the City. The responsibility for TIA preparation shall rest with the applicant and must be performed by a Professional Engineer (PE) licensed in the State of Texas with experience in traffic and transportation engineering. The final TIA report must be signed and sealed by the PE responsible for the analysis to be considered for review by the City. Application and review fees are due at the time of each submittal. City staff and consultants shall serve primarily in a review and advisory capacity and will only provide data to the applicant when available.
- (B) It shall be the responsibility of the applicant to submit one (1) printed and one (1) electronic PDF of the TIA reports and executive summaries prior to the zoning and/or development request submission. The proper number of reports, the timing for submission, and the review of these reports shall be based on standard City development review procedures. Incomplete TIAs or failure to submit a TIA prior to the submission shall delay consideration of zoning and development requests. Should it be determined during the review of any zoning and/or development plans that a TIA is required, consideration shall be deferred until the applicant submits a completed TIA, the TIA has been reviewed, and the City has approved the TIA.
- (C) The City and/or the City's consultant shall review the TIA and provide comments to the applicant. It shall be the responsibility of the applicant to submit one (1) printed and one (1) electronic PDF of the finalized TIA reports and executive summaries once all review



comments have been addressed. Electronic submission may substitute for the required hard copy only with written authorization of the City Engineer.

### SUBSECTION 2.21.07 | TIA STANDARDS

- (A) Capacity Analysis. A capacity analysis for appropriate peak periods shall be conducted for all driveways, intersections, and streets identified during the pre-development meeting. Capacity calculations shall include both near term and long-term projections. Capacity calculations must be based on the operational analysis technique contained in the most current edition of the Highway Capacity Manual (HCM). Alternative calculations must be approved by the City Engineer.
- (B) Design Level of Service. The minimum acceptable level of service (LOS) within the City shall be defined as LOS 'C' in the peak hour for all critical movements/intersections and links. All development impacts on both thoroughfare and intersection operations must be measured against this standard.
- (C) Trip Generation Resources. The City's standard for trip generation rates for various land use categories shall be those found in the latest edition of Trip Generation Manual published by the Institute of Transportation Engineers (ITE) or other published or recognized sources applicable to the region. Alternate trip generation rates may be accepted on a *case-by-case* basis if the applicant can provide current supporting data substantiating that their development significantly differs from the ITE rates. The City and/or City's consultant must approve alternative trip generation rates in writing in advance of the TIA submission.
- (D) Trip Reductions. Trip reductions for pass-by trips and mixed-use developments will be permitted, subject to analytical support provided by the applicant and approved by the City and/or the City's consultant on a *case-by-case* basis. Assumptions relative to automobile occupancy, transit mode share, or percentage of daily traffic to occur in the peak hour must be documented and will be considered subject to analytical support provided by the applicant.
- (E) Study Horizon Years. The TIA must evaluate the impact of the proposed development on both existing traffic conditions and future traffic conditions for the horizon year(s) as specified in [TABLE 2.10](#). Horizon year(s) are defined as any analysis year beyond the existing year. These applications should take into account the Master Thoroughfare Plan or pending amendments.
- (F) Traffic Data Collection. Appropriate traffic counts shall be collected. These shall include weekday/weekend daily and peak-hour traffic counts at all locations as directed by the City, weekday counts shall be taken on a typical Tuesday, Wednesday, or Thursday unless other days are required/approved. Peak-hour intersection turning movement counts shall include 15-minute increments. Traffic counts used in a TIA shall be less than one (1) year old and should occur outside of holiday time periods and when public schools are in session unless otherwise approve by the City Engineer. The City Engineer may request additional counts based on specific conditions. The existing counts shall be presented in figures/exhibits for each intersection counted with original data sheets provided in the *Appendix*.
- (G) Design Standards. The TIA must evaluate site access characteristics including, access spacing requirements, left/right-turn lane requirements, visibility and sight distance requirements, as needed, relative to City of Rockwall and Texas Department of Transportation (TXDOT) requirements, as appropriate. Any TIA with access to a TXDOT facility must meet TXDOT minimum standards and requirements.
- (H) Traffic Signal Timing and Phasing. The analysis of all existing traffic signals shall be based on the most current signal timing plans, if available. When signal timing plans are not available the assumed signal timing shall be based on field observations, actuation/detection capabilities and corridor coordination and offsets.

### SUBSECTION 2.21.08 | TIA METHODOLOGY

- (A) Site Location/Study Area. A brief description of the size, general features, and location of the site, including a map of the site in relation to the study area and surrounding vicinity. The description should include all existing and proposed traffic control devices within the study area, posted speed limits on all existing, adjoining or impacted roads, pedestrian facilities, intersection layout, and lane usages. If applicable to the project, information may also include lane widths and right of way widths for all existing roads impacted by the development. Photographs may be included to document existing transportation conditions.
- (B) Existing Zoning. A description of the existing zoning for the site and adjacent property, including land area by zoning classification and density by Floor Area Ration (FAR), square footage, number of hotel rooms, and dwelling units, etc. (*as applicable*).
- (C) Existing Development. A description of any existing development on the site and adjacent to the site. If applicable, include impacts to existing development.



- (D) Site Access. A description or illustration of the existing and proposed site access points and associated turn lanes and/or median openings, including cross-section, lane assignment, turn restrictions, throat width, curb radii, turn-lane requirements, sight distance calculations and access spacing conditions.
- (E) Proposed Zoning/Site Development. A description of the proposed zoning/development for the site, including land area by zoning classification and density by FAR, square footage, number of hotel rooms, and dwelling units, etc. (*as applicable*); identify recently approved or pending land uses within the area.
- (F) Thoroughfare System. A description and/or map of existing planned/proposed thoroughfares and traffic signals for horizon year(s) within the study area.
- (G) Model Assumptions and Design Factors. The roadway network must be modeled as accurately as possible using field data measurements, industry standards and engineering judgement. This includes, but is not limited to, intersection/roadway segment geometries, traffic flow characteristics and traffic signal phasing and operations.
- (H) Existing Traffic Volumes. Recent traffic counts for the study area including pedestrian and bike volumes where appropriate.
- (I) Projected Traffic Volumes. Background traffic projections within the study area for the horizon year(s). Background traffic projections shall include the growth in regional traffic as well as the traffic that will be generated by the undeveloped land adjacent to the site and/or within the study area that is likely to develop by the horizon year(s), as determined by the City Engineer and/or City's Consultant. These traffic projections shall be based upon recently approved development applications, the current zoning on the undeveloped land, the City's Future Land Use Plan or the requested future land use of the development.
- (J) Density of Development. A table displaying the amount of development assumed for existing zoning and/or the proposed development (*using gross floor area, dwelling units, occupied beds, etc., as required by the trip generation methodology*).
- (K) Existing Site Trip Generation. A table displaying trip generation rates and total trips generated by land use category for the appropriate peak hours and on a daily basis for each phase and full development based on existing zoning (*if applicable*), and including all appropriate trip reductions (*as approved by the City and/or City's consultant*).
- (L) Proposed Site Trip Generation. A table displaying trip generation rates and total trips generated by land use category for the appropriate peak hours and on a daily basis for each phase and full development based on existing zoning (*if applicable*) and/or proposed development, and including all appropriate trip reductions (*as approved by the City and/or City's consultant*).
- (M) Net Change in Trip Generation (For Rezoning Cases). Proposed trip generation minus existing trip generation (*if applicable*); the net increase in trips to be added to base volumes for the design year.
- (N) Trip Distribution and Traffic Assignment. Tables and/or figures/exhibits of trips generated by the proposed development (*or net change in trips, if applicable*) added to the existing and projected volumes, as appropriate, with distribution and assignment assumptions, unless computer modeling has been performed. Each step of the procedure should be clearly shown in enough detail so that all calculations can be verified.
- (O) Level of Service Evaluations. Capacity analyses for appropriate peak hours for both existing conditions and horizon year(s) projections for intersections, thoroughfare links, median openings and turn lanes associated with the site, as applicable. Results of the capacity analyses must be summarized in exhibits and/or tables for each analysis period and scenario providing the level of service designation and average control delay for each intersection overall and for each major lane group as applicable. Volume-to-capacity ratio and 95<sup>th</sup> percentile queues should be provided for all movements found to operate at a deficient level of service.
- (P) Intersection Control Evaluations. The need for new intersection controls (*i.e. traffic signals, all-way stop control*) shall be based on warrants and include their impact on the performance of the transportation system.
- (Q) Evaluation of Proposed/Necessary Mitigation. Capacity analyses for appropriate peak hours for intersections, thoroughfare links, median openings and turn lanes associated with the site under proposed/necessary traffic mitigation measures.
- (R) Conclusions. Identification of all thoroughfares, driveways, intersections, and individual movements that exceed LOS 'C' or any operational problems likely to occur.
- (S) Recommendations. Identify and summarize any necessary roadway improvements and time frames for improvements to occur. Include any intersections, turn lanes, etc. which will not be improved to LOS 'C' or better and support for why improvements are not provided. Mitigation measures should be consistent with Traffic Impact Mitigation section below.
- (T) Other Information Required for Proper Review. As requested by the City Engineer and/or the City's consultant.



### SUBSECTION 2.21.09 | TIA REPORT FORMAT

- (A) The TIA report must be prepared on 8½-inch by 11-inch sheets of paper; however, it may contain figures/exhibits on larger sheets, provided they are folded to this size. All text and map products shall be computer-based and provided in both published format and computer file format (PDF). In addition, all electronic files used as part of the traffic analysis (*i.e.*, *Synchro*, *HCS*, *Passer II/III*, *CORSIM*, *VISSIM*, *ARCADY*, *etc.*) shall be provided.
- (B) Traffic volumes must be illustrated on prepared figures/exhibits depicting appropriate movements at each study intersection. This includes, existing and horizon year(s) (*i.e.* *projected background traffic volumes*, *site generated traffic volumes*, *background and site generated*).
- (C) The sections of the TIA report should be categorized according to the outline shown below:

- I. Executive Summary
- II. Introduction
  - (a) Purpose & Overview of Study
- III. Existing Conditions
  - (a) Site Location/Study Area
  - (b) Existing Zoning/Development
  - (c) Study roads/streets and intersections
  - (d) Traffic Volumes
- IV. Proposed Development
  - (a) Zoning, phasing, densities, etc.
  - (b) Site Trip Generation
  - (c) Net Change in Trip Generation (as applicable)
  - (d) Trip Distribution and Traffic Assignment
- V. Projected Volumes
  - (a) Background Volumes
  - (b) Background + Site Volumes
- VI. Analysis
  - (a) Level of Service Evaluations
  - (b) Warrant studies (as applicable)
  - (c) Link Capacity (as applicable)
  - (d) Sight Distance (as applicable)
  - (e) Access Spacing (as applicable)
  - (f) Left-turn/Right-turn Lanes (as applicable)
  - (g) Accident (as applicable)
  - (h) Queuing (as applicable)
  - (i) Mitigations
- VII. Summary/Conclusions
- VIII. Recommendations
- IX. Appendices

### SUBSECTION 2.21.10 | TRAFFIC IMPACT MITIGATION

- (A) Mitigation of traffic impacts shall be required if the proposed development would cause a facility or traffic movement (*if applicable*) to exceed LOS 'C', or where it already exceeds LOS 'C' and the development would contribute five (5) percent or more of the total traffic during any projected horizon year. If mitigation is required, the applicant must only mitigate the impact of the proposed development, and would not be responsible for alleviating any deficiencies in the thoroughfare system that may occur without the proposed development.



- (B) Mitigation is not required if it can be shown that the traffic impacts of the project are fully mitigated ten (10) years after the final opening with any improvements that are already programmed to be implemented within five (5) years of the initial opening.

#### SUBSECTION 2.21.11 | ADMINISTRATION OF THE TIA

Based on the results of the TIA and actions recommended by the City staff, the City's consultant, the Planning & Zoning Commission and/or the City Council, as appropriate, the City shall take one or more of the following actions:

- (A) Approve the zoning or development request, if the project has been determined to have no significant impact or where the impacts can be adequately mitigated;
- (B) Approve the development request, subject to a phasing plan;
- (C) Recommend study of the City's Master Thoroughfare Plan to determine amendments required to increase capacity;
- (D) Recommend amendment of the Capital Improvement Program (CIP) to expedite construction of needed improvements; or
- (E) Deny the zoning or development request, where the impacts cannot be adequately mitigated.

#### SUBSECTION 2.21.12 | COST OF TIA REVIEW

The City may utilize an engineering consulting firm to assist City staff in the review of a TIA. The cost of this consultant review shall be borne by the developer, engineer, or property owner submitting the TIA. The City shall first obtain a cost estimate from the engineering consultant for the TIA review at time of the initial TIA submittal. Before the review begins, the developer, engineer, or property owner submitting the TIA shall deposit with the City funds equal to the cost estimate. The City shall disburse the funds to the consulting engineer as the review progresses. Should the consultant fees exceed the initial estimate, the developer, engineer or property owner submitting the TIA shall be informed of the shortage and a new estimate made by the consultant engineer to complete the TIA review. Additional funds will then be deposited with the City by the developer, engineer or property owner submitting the TIA to cover the estimated shortfall before the review of the study resumes. Any unused funds to be reimbursed to the developer, engineer or property owner submitting the TIA. If review process is performed by City staff, the City will submit a cost estimate for TIA review at time of the initial engineering submittal.





## CHAPTER 3 | STORM DRAINAGE FACILITIES

### SECTION 3.01 | INTRODUCTION

Drainage facilities shall be designed and constructed at such locations and of such size and dimensions to adequately serve the development and the contributing drainage area upstream of the development. The developer shall provide all the necessary easements and rights-of-way required for drainage structures including, but not limited to, storm drains, open channels (*lined or unlined*), flood detention facilities, and storm water diversion or containment facilities (*such as levees, dams, berms and stream diversions*). The minimum easement widths for drainage facilities shall be per [TABLE 3.1](#). Wider easements may be required by the City Engineer. For detention pond easements, public water lines and wastewater lines will not be allowed in the easement. A variance to allow retaining walls in a detention easement will require approval by the Planning and Zoning Commission with appeals being heard by the City Council. For new single-family residential subdivisions storm sewer infrastructure, detention ponds, floodplain, erosion hazard setback, and drainage easements shall not be located on a residential lot, and must be fully within a Homeowner's Association (HOA) maintained lot.

**TABLE 3.1: DRAINAGE EASEMENTS (MINIMUM WIDTHS)**

		MINIMUM EASEMENT WIDTH (FEET)
CONDUIT SIZE	LESS THAN 48 - INCH RCP	20
	48-INCH TO 72-INCH RCP	25
	BOX 3-FOOT TO 4-FOOT SPAN, RCB	20
	BOX 5-FOOT TO 8-FOOT SPAN, RCB	25
	BOX 9-FOOT TO 12-FOOT SPAN, RCB	30
DEPTH OF CONDUIT	< 14-FOOT	20
	14-FOOT TO 16-FOOT	25
	17-FOOT TO 20-FOOT	30
	21-FOOT TO 23-FOOT	35
	> 23-FOOT	40
OPEN CHANNEL	15-FOOT WIDER THAN TOP WIDTH OF CHANNEL ON BOTH SIDES	
EMERGENCY OVERFLOW FLUME	20	
CREEKS/STREAM/FLOODPLAINS	REFERENCE <a href="#">SECTION 3.2.16, EROSION HAZARD SETBACK</a>	
DETENTION PONDS	SET AT 100-YEAR FREEBOARD ELEVATION. (REFERENCE <a href="#">SECTION 3.3, MINIMUM FREEBOARD REQUIREMENTS</a> )	

The design flows for the drainage system shall be calculated by the *Rational Method* in accordance with the requirements set forth in this document unless otherwise noted within these *Standards* (*such as where the unit hydrograph methods are required*). Curbs, inlets, manholes, etc. shall be designed and constructed in accordance to the *Standard Details*. Materials and construction procedures shall conform to the requirements of the *Standard Specifications for Construction*.

The developer shall provide plans, specifications, and design calculations for all drainage structures. All open channels shall be designed to prevent erosion ([TABLE 3.12](#)). If an existing open channel is experiencing erosion or velocities are calculated to be erosive, the channel shall be modified to prevent erosion. The City shall specifically approve the type of methods used for prevention of erosion.

The design, size, type and location of all storm drainage facilities shall be subject to the approval of the Engineering Department. The requirements set forth herein are considered minimum requirements. *The developer and their engineers shall bear the total responsibility for the adequacy of design. The approval of the facilities by the City in no way relieves the developer and their engineer of this responsibility.*



The design factors, formulas, graphs and procedures described shall serve as means to prove that adequate conveyance of storm water and adequate flood prevention within the City is being provided. Responsibility for the actual design remains with the developers and design engineer of record. Deviation from the requirements of these standards shall require the approval of the City Engineer.

The City, as a participant in the National Flood Insurance Program (NFIP), must enforce all parts of its adopted Flood Hazard Damage Prevention and Erosion Control Ordinance, as approved by the Federal Emergency Management Agency (FEMA). Therefore, the requirements of that ordinance are adopted and included as a part of the City's *Standards of Design and Construction*.

The developer shall be responsible for the necessary facilities to provide drainage patterns and drainage controls such that properties within the overall watershed, whether upstream or downstream of the development, are not adversely affected by storm drainage from facilities on the development. These are outlined in the [SECTION 3.6, STORM DRAINAGE MANAGEMENT PLAN](#).

The *Storm Drainage Management Plan* provided as part of the final engineering drawings shall address how storm water on the proposed development and affected adjoining properties will be controlled during phased and completed development. Off-site improvements may be required to carry the additional flows caused by the proposed development. If the downstream system is insufficient to carry the proposed flow from the fully developed drainage area without causing potentially increased flood damages, detention will be required to release only the proportionate flow amount capable of being carried in the existing system for the drainage area. One site may not utilize all remaining capacity if undeveloped property part of the drainage area.

Storm drainage released from the site will be discharged to a natural water course or storm sewer system of an adequate size to convey the 100-year storm runoff expected after development.

All storm drainage structures shall be constructed with a minimum of 4,200 PSI concrete in 28-days with a cement content not less than 7.0 sack per cubic yard and no fly ash allowed. All batch designs shall be reviewed and approved by the Engineering Department. All batch designs shall have the current date, project name, and use labeled on each design. Submit batch designs to the Engineering Department a minimum of ten (10) days prior to the projected placement date for review and approval. If pre-cast structures are being utilized, shop drawings must be submitted to the City Engineer for approval along with the batch design which is provided by the manufacturer. All drainage structures shall be double formed. No earth forms will be allowed.

## [SECTION 3.02 | STORM DRAINAGE DESIGN CRITERIA](#)

### [SUBSECTION 3.02.01 | RATIONAL METHOD](#)

For all drainage areas less than 100-acres, the rational method of computing runoff may be used for design of small drainage facilities (such as storm sewer systems, inlets, street gutter, and small detention facilities). The *Rational Method* is expressed by [EQUATION 3.1](#).

#### [EQUATION 3.1: RATIONAL METHOD](#)

$$Q = CIA$$

#### WHERE:

Q = THE STORM FLOW RATE AT A GIVEN POINT (CFS)

C = RUNOFF COEFFICIENT (THE RATIO OF RAINFALL TO PEAK RUNOFF) AS INDICATED IN [TABLE 3.2](#)

I = THE AVERAGE INTENSITY OF RAINFALL, FOR A PERIOD EQUAL TO THE TIME OF FLOW FROM THE FARTHEST POINT OF THE DRAINAGE AREA TO THE POINT OF DESIGN AND IS OBTAINED FROM [FIGURE 3.1](#). (INCHES/HR)

A = THE AREA THAT IS CONTRIBUTING TO THE POINT OF DESIGN (ACRES)

#### [SUBSECTION 3.02.01.01 | RUNOFF COEFFICIENT \(C\)](#)

For design of proposed drainage facilities using the Rational Method, runoff coefficients shall be based on the future land use. The runoff coefficients for different land uses should be taken from [TABLE 3.2](#). A weighted runoff coefficient shall be used if different land uses are contributing to a discharge design point. Runoff coefficient used for design is based on zoning, not how the area is used (i.e. grassed area in a commercial zoned property will use C=0.9). Higher runoff coefficient may be required by City Engineer during zoning change.





**TABLE 3.2: RUNOFF COEFFICIENT FOR TYPES OF LAND USE**

TYPE OF AREA OR LAND USE	ADOPTED RUNOFF COEFFICIENT
FLOODPLAIN	0.35
SINGLE FAMILY RESIDENTIAL OR DUPLEX	0.50
SCHOOL	0.70
APARTMENTS	0.75
TOWNHOUSE	0.80
CHURCHES	0.80
INDUSTRIAL	0.90
COMMERCIAL BUSINESS	0.90
MERCANTILE DISTRICT	0.90
RETAIL	0.90
PARKING LOT	0.90
MAJOR AND MINOR ARTERIALS (ROW)	0.90

**SUBSECTION 3.02.01.02 | TIME OF CONCENTRATION**

The time of concentration is defined as the longest time, without unreasonable delay, that will be required for water to flow from the upper limit of a drainage area to the point of concentration. The time of concentration to any point in a storm drainage system is a combination of the “inlet time” and the time of flow in the storm drain. The inlet time is the period of time required for water to flow over the surface of the ground to the storm drain inlet. The time of concentration for any one design point shall not exceed ten (10) minutes for storm drain designs.

Using the *Rational Method* for small drainage acres under average conditions, the minimum time of concentration from the upstream end of a drainage system will coincide with [TABLE 3.3](#).

**TABLE 3.3: MINIMUM INLET TIME OF CONCENTRATION**

TYPE OF AREA OR LAND USE	MINIMUM INLET TIME (MINUTES)
FLOODPLAIN	20
SINGLE FAMILY RESIDENTIAL OR DUPLEX	10
SCHOOL	10
APARTMENTS	10
TOWNHOUSE	10
CHURCHES	10
INDUSTRIAL	10
COMMERCIAL BUSINESS	10
MERCANTILE DISTRICT	10
RETAIL	10
PARKING LOT	10
MAJOR AND MINOR ARTERIALS (ROW)	10

Under circumstances which will produce times of concentration in excess of those shown in [TABLE 3.3](#) the following NRCS TR55 methodology shall be used to determine the time of concentration (Tc). This method separates the flow through the drainage area into sheet flow, shallow concentrated flow, and open channel flow. The Tc is the sum of travel times for sheet flow, concentrated shallow flow and open channel flow. The time of concentration flow path and sheet flow path and following calculations shall be shown in the plans.

- (A) *Sheet Flow*. The maximum allowable length for sheet flow shall be no more than 100-feet, if not prior to 100-feet. Guidelines for determining the maximum allowable sheet flow length are provided in *Unit Hydrograph Method* Section. The Tt in minutes for sheet flow is determined using [EQUATION 3.2](#):



### EQUATION 3.2: TRAVEL TIME IN MINUTES FOR SHEET FLOW

$$T_t = \frac{0.007(nl)^{0.8}}{(P_2)^{0.5}S^{0.4}}$$

#### WHERE:

$T_t$  = TRAVEL TIME, (HR)

$n$  = MANNING'S ROUGHNESS COEFFICIENT, ([TABLE 3.4](#))

$L$  = FLOW LENGTH, (FT)

$P_2$  = 2-YEAR, 24-HOUR RAINFALL, ([TABLE 3.5](#))

$S$  = LAND SLOPE OF HYDRAULIC GRADE LINE (FT/FT)

### TABLE 3.4: SHEET FLOW 'n' VALUES

SURFACE DESCRIPTION	n <sup>1</sup>
SMOOTH SURFACES (CONCRETE, ASPHALT, GRAVEL, OR BARE SOIL)	0.011
FALLOW (NO RESIDUE)	0.05
CULTIVATED SOILS:	
RESIDUE COVER LESS THAN 20%	0.06
RESIDUE COVER 20% OR GREATER	0.17
GRASS:	
SHORT PRAIRIE GRASS	0.15
DENSE GRASSES	0.24
BERMUDA GRASS	0.41
RANGE (NATURAL)	0.13
WOODS:	
LIGHT UNDERBRUSH	0.40
DENSE UNDERBRUSH	0.80

#### NOTES:

<sup>1</sup>: THESE "n" VALUES ARE ONLY APPLICABLE FOR FLOW DEPTHS OF APPROXIMATELY 0.1 FOOT OR LESS WHERE SHEET FLOW OCCURS. FOR GREATER FLOW DEPTHS, TYPICALLY CONCENTRATED SHALLOW OVERLAND FLOW OR CHANNEL FLOW OCCURS, WITH LOWER "n" VALUES TYPICAL OF THOSE GENERALLY USED IN OPEN-CHANNEL FLOW.

- (B) Shallow concentrated flow travel time is computed by [EQUATION 3.3](#).

### EQUATION 3.3: SHALLOW CONCENTRATED FLOW TRAVEL TIME

$$t_{sc} = \frac{L_{sc}}{3600KS_{sc}^{0.5}}$$

#### WHERE:

$t_{sc}$  = SHALLOW CONCENTRATED FLOW TIME, (HR)

$L_{sc}$  = SHALLOW CONCENTRATED FLOW LENGTH, (FT)

$K$  = 16.13 FOR UNPAVED SURFACE, 20.32 FOR PAVED SURFACE

$S_{sc}$  = SHALLOW CONCENTRATED FLOW SLOPE, (FT/FT)

- (C) Channel Flow travel time shall be computed by dividing the channel length by the flow rate obtained from Manning's Equation. This is shown by [EQUATION 3.4](#).

### EQUATION 3.4: CHANNEL FLOW TRAVEL TIME

$$t_{ch} = \frac{L_{ch}}{3600 \frac{1.49}{n} R^{\frac{2}{3}} S_{ch}^{\frac{1}{2}}}$$

WHERE:

$t_{ch}$  = CHANNEL FLOW TIME, (HR.)

$L_{ch}$  = CHANNEL FLOW LENGTH, (FT)

$S_{ch}$  = CHANNEL FLOW SLOPE, (FT/FT)

$n$  = MANNING'S ROUGHNESS COEFFICIENT (TABLE 3.11)

$R$  = CHANNEL HYDRAULIC RADIUS (FT),  $R = \frac{a}{p_w}$

WHERE:  $A$  = CROSS SECTIONAL AREA (FT<sup>2</sup>)

$p_w$  = WETTED PERIMETER (FT)

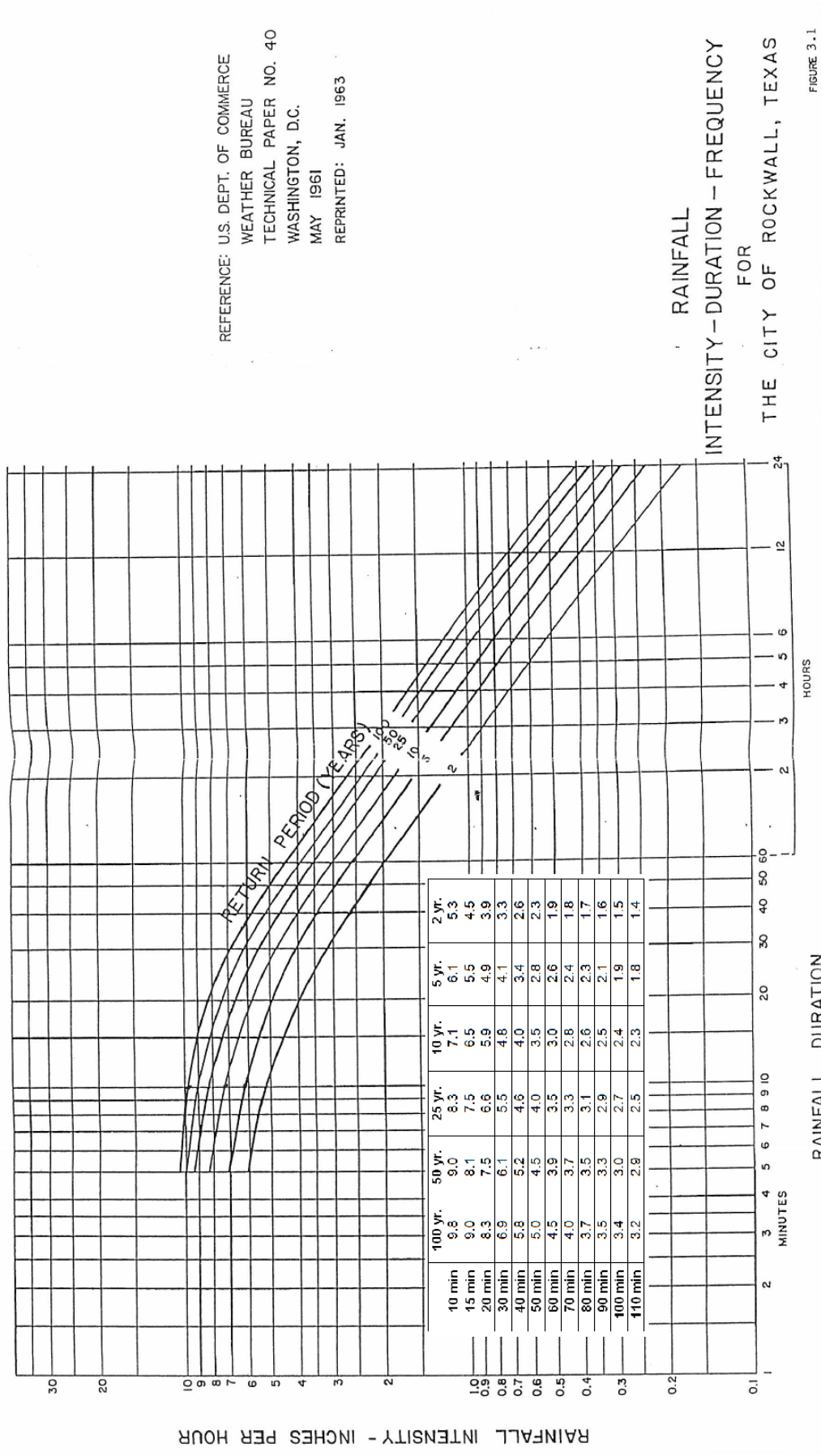
Since urbanization is anticipated in all drainage areas, all drainage improvements shall be designed for the case of fully developed watersheds. It is generally not practical to design improvements to gravity drainage systems in stages to match development, except in the case of unlined ditches, and then, it is essential that ultimate rights-of-way or easements be obtained at the outset. When the watershed in question is basically undeveloped, the developer shall attempt to anticipate future fully developed conditions and storm water drainage patterns and flow characteristics when determining the time of concentration.

SUBSECTION 3.02.01.03 | RAINFALL INTENSITY

The Rainfall intensity shall be taken from [FIGURE 3.1](#) below for the minimum inlet time above.



FIGURE 3.1: IDF CURVE





### SUBSECTION 3.02.02 | UNIT HYDROGRAPH METHOD

For contributing drainage areas greater than 100-acres, the unit hydrograph method, shall be used to determine the peak storm discharge quantities. This method shall also be used for verification of adequacy of storm water detention facilities with contributing drainages areas that are equal to or greater than 20-acres.

The City will utilize an engineering consulting firm to assist City staff in the review of a flood and detention studies that utilize the *Unit Hydrograph Method*. The cost of this consultant review shall be borne by the developer, engineer, or property owner submitting the study. Before the review begins, the developer, engineer, or property owner submitting the study shall deposit with the City the consultant's review retainer fee. The City shall disburse the funds to the consulting engineer as the review progresses. Should the consultant fees exceed the initial estimate, the developer, engineer or property owner submitting the study shall be informed of the shortage to complete the study review. Additional funds will then be deposited with the City by the developer, engineer or property owner submitting the study to cover the additional reviews before the review of the study resumes. Any unused funds to be reimbursed to the developer, engineer or property owner submitting the study. If review process is performed by City staff, the City will submit a cost estimate for study review at time of the initial engineering submittal.

The use of a unit hydrograph method shall be based upon standard and accepted engineering principles used in the profession. Acceptable methods include the Natural Resources Conservation Service (NRCS) Technical Release Number 55 (TR-55) for drainage areas 100-acres to 2,000-acres and NRCS's Technical Release Number 20 (TR-20), or the United States Army Corps of Engineers HEC-HMS models for drainage areas 100-acres or more. When the flood study involves a watershed that does not already have any available hydrology model, or in the case where conversion of an existing model to a later version hydrology model is desired, use of the latest version of HEC-HMS model available is required.

When the unit hydrograph method is used, a flood study report shall be prepared and provided to the City Engineer, documenting the methodology, assumptions, derivation of all data used, and results of the study. In order to maintain consistency of all hydrologic studies within the City, the following requirements/conditions shall be used when performing the unit hydrograph method. These requirements/conditions shall be included in the plan set and the flood study report:

- (A) Use the NRCS 24-hour Type III Rainfall Distribution.
- (B) Use wet antecedent soil moisture conditions (AMC-III).
  - (1) Storm runoff/loss parameter calculations, such as NRCS runoff curve numbers (CN). CN values should first be computed based on average antecedent soil moisture conditions (AMC-II) to the nearest 0.1 value (CN<sub>2</sub>), based on hydrologic soil group, land cover and treatment practices. Then compute the CN<sub>3</sub> value for AMC-III conditions, to the nearest 0.1 value, using the NRCS conversion equation, [EQUATION 3.5](#).

#### EQUATION 3.5: NRCS CONVERSION EQUATION

$$CN_3 = \frac{23CN_2}{10 + 0.13CN_2}$$

- (C) Compute both pre-construction conditions (*based on existing off-site watershed conditions*) and post-construction conditions and show comparison in summary table of results.
- (D) In addition to (C), compute projected future fully developed conditions to determine design elevations and erosion protection.
- (E) 24-hour rainfall storm totals, (See [TABLE 3.5](#))
- (F) Time of Concentration (T<sub>c</sub>) and Lag Time Calculations, computed to the nearest one (1) minute: The lag time is generally considered to be 0.6 x T<sub>c</sub>. The T<sub>c</sub> calculations should include sheet flow travel time, shallow concentrated flow travel time, channel flow travel time, and travel time associated with any storm sewer system pipes, street gutter flow, and other travel times. Storm sewer pipe travel time may be derived based on design velocities and pipe flow lengths from available or proposed sewer pipe plans. General guidelines pertaining to NRCS TR-55 methodology for determining flow times for sheet flow, concentrated shallow flow, channel flow, and other flow types are included in the section above. The length of sheet flow used with the unit hydrograph method should be determined based on the following procedures to determine where sheet flow ends:



- (1) Field investigations, where possible, to detect overland drainage patterns and where sheet flow transitions to other types of overland or pipe flow (*such as observation of beginning of overland flow rill erosion patterns or entrance to a storm water inlet*).
- (2) Information from topographic maps, such as deflections in elevation contours indicating where sheet flow ends and shallow concentrated flow or channel flow may begin.
- (3) For areas where previous construction has occurred, review of as-built drainage plans.
- (4) High-resolution photography, which may indicate locations where overland flow begins to form shallow concentrated flow as evidenced by erosion patterns.
- (5) If the length of sheet flow cannot be determined by the above procedures, or if it is determined by the above procedures to be greater than 100-feet, the maximum length to be used shall be the lesser of 100-feet or the length computed by [EQUATION 3.6](#) [as taken from the NRCS National Engineering Handbook, Part 630; Hydrology, Chapter 15]:

#### EQUATION 3.6: MAXIMUM SHEET FLOW LENGTH

$$L = \frac{100S^{0.5}}{n}$$

#### WHERE:

L = LIMITING SHEET FLOW LENGTH, (FT)

S = LAND SLOPE OVER LENGTH L, (FT/FT)

n = MANNING'S ROUGHNESS COEFFICIENT OVER LENGTH L

- (G) When using a unit hydrograph procedure, mixing the hydrology modeling data with data based on differing procedures is not acceptable:
  - (1) The time of concentration should be calculated using actual travel time computations. [Do not assume a ten (10) minute inlet time as assumed in Rational Method].
  - (2) Use total storm precipitations (inches) listed in [TABLE 3.5](#) [Do not use rainfall intensities (inches/hour) or derive total storm precipitation based on the Rational Method rainfall intensities].
  - (3) For detention ponds with drainage areas greater than 20-acres, if a proposed pond and dam is first designed based on Modified Rational Method, but is found to be inadequate when checked with the unit hydrograph method, then it should be re-designed to safely pass the maximum required design storm using the unit hydrograph method, without flow passing over the top of the dam (and with required freeboard) and without increased discharges being passed downstream from the project site.
- (H) Drainage areas shall be rounded to the nearest 0.01-acre (0.000001 sq. mi.) in hydrology models, as well as for areas of land use and soil categories when computing composite runoff curve numbers.
- (I) Impervious areas of a drainage basin should be included within the computed composite runoff curve number calculations used in the hydrology models (*instead of using a percentage of impervious area in combination with a weighted curve number in hydrology models that contain that option*).
- (J) Stream reach hydrograph routing computations within hydrology models must be performed using a procedure that accounts for the effects of channel and floodplain storage (*such as Modified Puls Method*), so that impacts on flood discharges due to loss of flood valley storage within the reach, whether caused by currently proposed construction or due to future development, can be determined.
- (K) NRCS runoff curve numbers listed in NRCS's Technical Release 55 (TR-55) for urban and residential districts are generally inappropriate for typical developments in the City of Rockwall, due to the indicated low percentage of impervious areas indicated with the values. Therefore, curve numbers typical of conditions in the City of Rockwall are included in [TABLE 3.6](#). These values should be used in most cases; however, other curve numbers for conditions not listed in [TABLE 3.6](#) may be derived and used if reasonably justified and documented.
- (L) Options available in hydrology models to automatically compute pond spillway discharges, based on spillway or outlet type or configuration, are sometimes limited and often do not adequately represent the designed spillway. In such cases, pond water surface elevations versus discharges may need to be computed by other methods and entered into the hydrology model as user defined paired data.



**TABLE 3.5: PRECIPITATION FREQUENCY ESTIMATES IN INCHES FOR ROCKWALL, TEXAS**

AVERAGE RECURRENCE INTERVAL IN YEARS	DURATION														
	MINUTES					HOURS					DAYS				
	5	10	15	30	60	2	3	6	12	24	2	3	4	7	10
1	-	-	-	1.23	1.60	1.85	2.03	2.44	2.88	3.30	-	-	-	-	-
2	0.495	0.83	1.06	1.47	1.90	2.31	2.54	3.03	3.52	4.09	4.76	-	5.53	6.35	7.09
5	0.58	0.97	1.24	1.79	2.36	3.08	3.35	4.02	4.77	5.48	6.21	-	7.22	8.39	9.24
10	0.64	1.07	1.37	2.02	2.69	3.62	3.95	4.75	5.64	6.57	7.39	-	8.40	9.83	10.90
25	0.73	1.22	1.57	2.35	3.17	4.25	4.65	5.73	6.59	7.67	8.80	-	10.12	11.56	12.87
50	0.80	1.34	1.72	2.61	3.53	4.75	5.20	6.35	7.50	8.70	9.91	-	11.54	13.25	14.53
100	0.87	1.47	1.88	2.87	3.90	5.25	5.77	7.02	8.50	9.75	11.32	-	13.09	14.60	16.25
500	-	-	-	-	-	-	-	-	-	12.0	-	-	-	-	-
PROBABLE MAXIMUM PRECIPITATION	-	-	-	-	-	-	-	30.8	36.4	41.5	46.80	49.2	-	-	-

**REFERENCES:** U.S. DEPARTMENT OF COMMERCE/ NATIONAL OCEANIC AND ATMOSPHERIC ADMINISTRATION/ NATIONAL WEATHER SERVICE AND U.S. DEPARTMENT OF THE ARMY:

- (1) TECHNICAL MEMORANDUM NWS HYDRO-35, FIVE- TO 60-MINUTE PRECIPITATION FREQUENCY FOR THE EASTERN AND CENTRAL UNITED STATES, JUNE 1977.
- (2) TECHNICAL PAPER NO. 40, RAINFALL FREQUENCY ATLAS OF THE UNITED STATES FOR DURATIONS FROM 30 MINUTES TO 24 HOURS AND RETURN PERIODS FROM 1 TO 100 YEARS, MAY 1961.
- (3) TECHNICAL PAPER NO. 49, TWO- TO TEN-DAY PRECIPITATION FOR RETURN PERIODS OF 2 TO 100 YEARS IN THE CONTIGUOUS UNITED STATES, 1961.
- (4) HYDROMETEOROLOGICAL REPORT NO. 51, PROBABLE MAXIMUM PRECIPITATION ESTIMATES, UNITED STATES EAST OF THE 105TH MERIDIAN, JUNE 1978.

**GENERAL NOTE:** FOR RAINFALL DURATIONS OF 5 MINUTES THROUGH 60 MINUTES, RAINFALL FREQUENCY ESTIMATES FOR RETURN PERIODS OF 2 YEARS THROUGH 100 YEARS ARE BASED ON TECHNICAL MEMORANDUM NWS HYDRO-35, WHICH SUPERSEDES VALUES PRESENTED IN TECHNICAL PAPER NO. 40.



**TABLE 3.6: NRCS RUNOFF CURVE NUMBERS (AMC<sub>II</sub>) FOR VARIOUS LAND USE CLASSIFICATIONS**

LAND USE CLASSIFICATION	HYDROLOGIC SOIL GROUP			
	A	B	C	D
WOODED (WF)	36	60	73	79
WOODED (WG)	30	55	70	77
OPEN SPACE/RANGE/PASTURE (OSF)	49	69	79	84
OPEN SPACE/RANGE/PASTURE (OSG)	39	61	74	80
CULTIVATED, STRAIGHT ROW (CSR)	72	81	88	91
CULTIVATED, CONTOURED W/O TERRACING (CC)	70	79	84	88
CULTIVATED, CONTOURED AND TERRACED (CCT)	66	74	80	82
RESIDENTIAL (R20) <sup>2</sup>	59	74	82	86
RESIDENTIAL (R30) <sup>2</sup>	60	75	83	87
RESIDENTIAL (R40) <sup>2</sup>	66	78	85	88
RESIDENTIAL (R50) <sup>2</sup>	69	80	86	89
RESIDENTIAL (R60) <sup>2</sup>	74	83	88	91
RESIDENTIAL (R70) <sup>2</sup>	80	87	91	93
BARE SOIL	77	86	91	94
COMMERCIAL/BUSINESS/MULTIFAMILY (CBM)	89	92	94	95
INDUSTRIAL	81	88	91	93
DIRT OR GRAVEL ROADS, R.O.W. (RD)	76	85	89	91
PAVED ROADS, R.O.W. (RP)	83	89	92	93
INUNDATED (W)	100	100	100	100
URBAN HIGH RUNOFF EQUIVALENT <sup>1</sup>	83	89	92	94

**NOTES:**

<sup>1</sup>: URBAN HIGH RUNOFF EQUIVALENT IS USED ONLY FOR PROJECTED FULLY-DEVELOPED WATERSHED CONDITIONS.

<sup>2</sup>: RESIDENTIAL CODING REFERS TO PERCENT IMPERVIOUS [FOR EXAMPLE, R60 IS FOR 60% IMPERVIOUS] (FOR AREAS THAT FALL BETWEEN LISTED VALUES, PLEASE ROUND TO THE NEAREST CODING).

**GENERAL NOTES:**

CURVE NUMBERS LISTED ABOVE ARE FOR AVERAGE ANTECEDENT MOISTURE CONDITIONS (AMC II).

**SUBSECTION 3.02.03 | DESIGN STORM FREQUENCIES**

The design storm frequencies shall be the 5-year, 10-year, 25-year, 50-year, and 100-year storms.

For the Rational Method the relationship between rainfall intensity, duration and frequency is set forth in [FIGURE 3.1](#). These curves have been developed using Technical Paper No. 40, *Rainfall Frequency Atlas of the United States* by the U.S. Weather Bureau.

For the *Unit Hydrograph Method*, the total rainfall for the 24-hour duration storm is used. See [TABLE 3.5](#).

**SUBSECTION 3.02.04 | DRAINAGE CALCULATIONS SUMMARY TABLES**

The calculations of the storm water discharge shall be provided to the City by the Engineer. As a minimum, the engineering plans shall include:

- (A) Existing and Proposed Drainage Area Calculations Table using [FORM 3.1](#).
- (B) Inlet Calculations Table using [FORM 3.2](#).
- (C) Storm Sewer Calculations Table using [FORM 3.3](#).
- (D) Open Channel Calculations Table using [FORM 3.4](#).
- (E) Culvert Design Calculations Table using [FORM 3.5](#).



**FORM 3.1: DRAINAGE AREA CALCULATIONS TABLE**

AREA ID	TOTAL DRAINAGE AREA	FLOODPLAIN (C=0.35)	RESIDENTIAL (C=0.50)	COMMERCIAL (C=0.90)	WEIGHTED RUNOFF COEFFICIENT (C)	C x A	TIME OF CONCENTRATION (T <sub>c</sub> )	DESIGN STORM FREQUENCY	INTENSITY (I)	STORM RUNOFF (Q)	DRAINS TO/REMARKS
(1)	(2)	(3)	(4)	(5)	(6)	(7)	(8)	(9)	(10)	(11)	(12)
	ACRES	ACRES	ACRES	ACRES	ACRES	ACRES	MINUTES	YEARS	INCHES/HOUR	CFS	

**INSTRUCTIONS FOR FORM 3.1: DRAINAGE AREA CALCULATION TABLE**

COLUMN (1)	DRAINAGE AREA IDENTIFICATION NUMBER OR DESIGNATION
COLUMN (2)	TOTAL DRAINAGE AREA IN ACRES
COLUMN (3 TO 5)	AREA DRAINED FOR EACH LAND USE TYPE IN ACRES (ADD ADDITIONAL COLUMNS FOR DIFFERENT LAND USE AREAS AS NEEDED) RUNOFF COEFFICIENT TAKEN FROM <a href="#">TABLE 3.2</a>
COLUMN (6)	WEIGHTED RUNOFF COEFFICIENT CALCULATED FROM COLUMNS 2 TO 5
COLUMN (7)	PRODUCT OF COLUMN (2) AND COLUMN (6)
COLUMN (8)	MINIMUM INLET TIME OF CONCENTRATION TAKEN FROM <a href="#">TABLE 3.3</a>
COLUMN (9)	DESIGN STORM FREQUENCY, SHALL BE 100-YR FOR ALL AREAS
COLUMN (10)	USING THE TIME OF CONCENTRATION AND DESIGN STORM FREQUENCY, THE RAINFALL INTENSITY IS TAKEN FROM <a href="#">FIGURE 3.1</a>
COLUMN (11)	SOLUTION OF <a href="#">EQUATION 3.1</a>
COLUMN (12)	A DETAILED DESCRIPTION OF WHERE THE DRAINAGE AREA DRAINS TO INCLUDING BUT NOT LIMITED TO INLET ID, STREET LOCATION, CREEK NAME, DETENTION POND DESIGNATION, ETC.

**SUBSECTION 3.02.05 | FLOW IN STREETS**

Capacity of Arterials, Collectors and Residential streets shall be calculated using a straight crown. Storm water flow in streets having a straight crown shall be calculated as follows:

**EQUATION 3.7: STORM WATER FLOW IN STREETS**

$$Q = \frac{0.56}{n} S_x^{\frac{5}{3}} S^{\frac{1}{2}} T^{\frac{8}{3}}$$

**WHERE**

- Q = GUTTER FLOW RATE (CFS)
- n = MANNING'S ROUGHNESS COEFFICIENT; VALUE = 0.0175
- S = THE LONGITUDINAL SLOPE OF THE STREET GUTTER (FEET/FEET)
- S<sub>x</sub> = PAVEMENT CROSS SLOPE (FEET/FEET)
- T = PONDED WIDTH (FEET)

**SUBSECTION 3.02.06 | FLOW IN ALLEYS**

Capacity of alleys should be taken from *Manning's Equation*:



### EQUATION 3.8: MANNING'S EQUATION

$$Q = \frac{1.49}{n} AR^{2/3} S^{1/2}$$

#### WHERE

Q = ALLEY FLOW RATE (CFS)

n = MANNING'S ROUGHNESS COEFFICIENT; VALUE = 0.0175

A = CROSS SECTIONAL AREA OF FLOW (FEET<sup>2</sup>)

R = HYDRAULIC RADIUS (FEET)

S = THE LONGITUDINAL SLOPE OF THE ALLEY (FEET/FEET)

### SUBSECTION 3.02.07 | PERMISSIBLE SPREAD OF WATER (PONDING WIDTH)

#### SUBSECTION 3.02.07.01 | GENERAL

Spread of water refers to the amount of water that may be allowed to collect in streets during a storm of specific design frequency. The following [EQUATION 3.9](#), a re-arranging of [EQUATION 3.7](#), shall be used to determine the ponding width "T" for straight crowned streets (*Arterials, Collectors and Residential*).

### EQUATION 3.9: PONDING WIDTH "T" FOR STRAIGHT CROWNED STREETS

$$T = 1.24 \left( \frac{Qn}{S_x^{5/3} S^{1/2}} \right)^{3/8}$$

#### WHERE

Q = GUTTER FLOW RATE (CFS)

n = MANNING'S ROUGHNESS COEFFICIENT; VALUE = 0.0175

S = THE LONGITUDINAL SLOPE OF THE STREET GUTTER (FEET/FEET)

S<sub>x</sub> = PAVEMENT CROSS SLOPE (FEET/FEET)

T = PONDED WIDTH (FEET)

In order that excess storm water will not collect in streets during a storm of the design frequency, the following spread of water values shall be used for the various types of streets. [FIGURE 3.2](#) provided below shows the relationship between thoroughfare type, gutter flow capacity and street slope based on maximum permissible ponding width described in the next sub-sections.

#### SUBSECTION 3.02.07.02 | MAJOR AND MINOR DIVIDED ARTERIALS (P6D & A4D)

Based on pavement cross-slope of 2.00%, the *100-year Design Frequency* flow shall not exceed the elevation of the lowest top of curb. The design engineer shall verify that one lane of traffic in each direction shall remain free of ponding in the 100-year storm event.

#### SUBSECTION 3.02.07.03 | COLLECTOR STREETS (M4U, M3U, & MINOR COLLECTOR)

Based on a straight cross-slope with a roof top crown of six (6) inches, the 100-year storm event flows shall not exceed the top of curb, six (6) inches.

#### SUBSECTION 3.02.07.04 | RESIDENTIAL

Based on a straight cross-slope with a roof top crown of six (6) inches, the 100-year storm event flows shall not exceed the top of curb, six (6) inches.

#### SUBSECTION 3.02.07.05 | ALLEYWAYS

The *100-year Design Frequency* shall not exceed the capacity of the alley pavement, a depth of five (5) inches. No ponding will be allowed beyond the pavement edge. Alley paving to be warped to drain the paving toward the inlet.

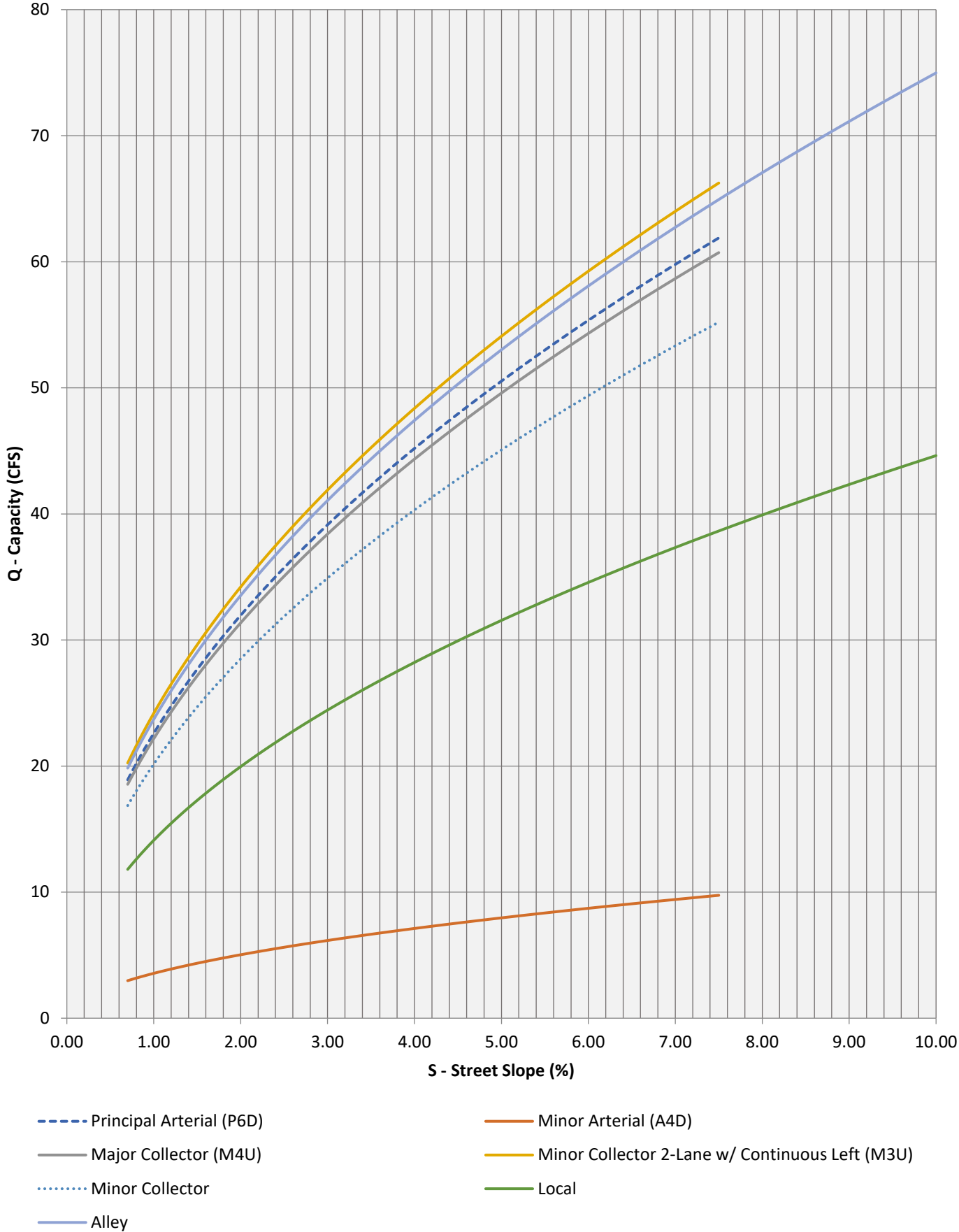


SUBSECTION 3.02.07.06 | PARKING LOTS

The 100-yr design frequency shall not exceed a depth of six (6) inches except where on pavement detention is occurring where one (1) foot in depth is permissible.



FIGURE 3.2: THOROUGHFARE GUTTER CAPACITY BASED ON MAXIMUM PERMISSIBLE PONDING WIDTH





## SUBSECTION 3.02.08 | INLET DESIGN

### SUBSECTION 3.02.08.01 | GENERAL

Determination of the required size of the storm drain inlets will be based on the calculations called out in this section and the instructions for [FORM 3.2: INLET DESIGN CALCULATIONS TABLE](#).

### SUBSECTION 3.02.08.02 | TYPES OF INLETS

The City requires the use of depressed curb inlets. A depressed curb inlet is more efficient than a non-depressed inlet because a depressed inlet induces a greater cross-flow toward the inlet allowing less water to flow past it. Also, the transition out of the depression causes a backwater effect, which further increases the capacity of the storm drain. A gutter depression for all curb inlets shall be six (6) inches, as shown in the *Standard Details*. Inlets shall be sized in multiples of five (5) feet (*i.e.* 5, 10, 15 and 20). Construction of inlets shall be in accordance with the *Standard Details*. Use [TABLE 3.7](#) for the selection of inlets to be used within the City. No grate inlets are allowed without approval from the City Engineer.



**TABLE 3.7: STORM DRAIN INLETS**

INLET DESCRIPTION	AVAILABLE INLET SIZES	WHERE USED	DESIGN EQUATIONS
STANDARD CURB OPENING INLET ON GRADE	5' 10' 15' 20'	ARTERIALS (P6D & A4D) COLLECTORS (M4U, MINOR & M3U) LOCAL (RESIDENTIAL) ALLEY	<a href="#">EQUATION 3.10</a> , <a href="#">EQUATION 3.11</a> , <a href="#">EQUATION 3.12</a> , <a href="#">EQUATION 3.13</a> , <a href="#">EQUATION 3.14</a> , <a href="#">EQUATION 3.15</a> , <a href="#">EQUATION 3.16</a> , <a href="#">EQUATION 3.17</a> & <a href="#">EQUATION 3.18</a>
STANDARD CURB OPENING INLET AT LOW POINT	5' 10' 15' 20'	ARTERIALS (P6D & A4D) COLLECTORS (M4U, MINOR & M3U) LOCAL (RESIDENTIAL) ALLEY	<a href="#">EQUATION 3.19</a> & <a href="#">EQUATION 3.20</a>
RECESSED CURB OPENING INLET ON GRADE	5' 10' 15' 20'	<b>STREET GRADE 6% OR GREATER</b> ARTERIALS (P6D & A4D) COLLECTORS (M4U, MINOR & M3U)	<a href="#">EQUATION 3.10</a> , <a href="#">EQUATION 3.11</a> , <a href="#">EQUATION 3.12</a> , <a href="#">EQUATION 3.13</a> , <a href="#">EQUATION 3.14</a> , <a href="#">EQUATION 3.15</a> , <a href="#">EQUATION 3.16</a> , <a href="#">EQUATION 3.17</a> & <a href="#">EQUATION 3.18</a>
COMBINATION INLET ON GRADE	4' 6' 8'	COMBINATION INLETS TO BE USED WHERE SPACE BEHIND CURB PROHIBITS OTHER INLET TYPES AND ALLEYS <b>CITY ENGINEER APPROVAL REQUIRED</b>	
COMBINATION INLET AT LOW GRADE	4' 6' 8'	COMBINATION INLETS TO BE USED WHERE SPACE BEHIND CURB PROHIBITS OTHER INLET TYPES AND ALLEYS <b>CITY ENGINEER APPROVAL REQUIRED</b>	
GRATE INLET	2 GRATE 3 GRATE 4 GRATE 6 GRATE	<b>NO GRATE INLETS ARE ALLOWED WITHOUT APPROVAL FROM THE CITY ENGINEER</b>	
DROP INLET	2'x2' 3'x3' 4'x4' 5'x5'	OPEN CHANNELS/AREA DRAIN	<a href="#">EQUATION 3.21</a> & <a href="#">EQUATION 3.22</a>

**SUBSECTION 3.02.08.03 | LOCATION**

All inlets (*edge of opening*) shall be a minimum of ten (10) feet from street or driveway curb return. Recessed inlets will be required to be installed at all inlet locations where the street grade is to be six (6) percent or greater except on residential streets. At locations where depressed inlets are expected to interfere with pedestrian activity, usually at crosswalks or interior spans of the block used for parking, a depression of less than six (6) inches may be required. These locations may require additional inlet length to compensate for the reduced depression. The City will consider all variances from a standard six (6) inch gutter on an individual basis.

- (A) Major and Minor Arterials (Divided). Inlets shall be located at street intersections, at low points of grade or where the gutter flow exceeds the permissible spread of water criteria. Inlets shall be located, when possible, on lesser traveled streets or alleys when grades permit. Inlets located on arterials and where street grade is six (6) percent or greater shall be recessed in order to minimize interference of the gutter depression with travel lanes. In super-elevated sections, inlets placed against the center medians shall have no gutter depression and shall intercept gutter flow at the point of vertical curvatures to prevent flow from crossing the arterial. Unless expressly approved by the City Engineer, storm waters will not be allowed to cross arterials on the surface in valley gutters or otherwise. All sag inlets will require a reinforced concrete emergency overflow flume. The capacity of the emergency overflow flume shall equal or exceed the 100-year design storm flow coming to the sag point.
- (B) Collector Streets. Inlets shall be located at street intersections, low points of grade or where the gutter flow exceeds the permissible spread of water criteria. Inlets shall be located, when at all possible, on lesser traveled streets or alleys where grade permits. All sag inlets will require a reinforced concrete emergency overflow flume. The capacity of the emergency overflow flume shall equal or exceed the 100-year design storm flow coming to the sag point.



- (C) Residential Streets. Inlets shall be located at street intersections, low points of grade or where the gutter flow exceeds the permissible spread of water criteria. All sag inlets will require a reinforced concrete emergency overflow flume unless the design engineer calculates that the street will carry the overflow above the crest of the roadway without the water surface elevation exceeding the top of curb. The capacity of the emergency overflow flume shall equal or exceed the 100-year design storm flow coming to the sag point.
- (D) Alleys. Inlets shall be located before intersections with streets, alley to alley intersections, change in alley directions, low points of grade or where the gutter flow exceeds the permissible spread of water criteria. All sag inlets will require a reinforced concrete emergency overflow flume. The capacity of the emergency overflow flume shall equal or exceed the 100-year design storm flow coming to the sag point.
- (E) Parking Lots. Inlets shall be located at all sag points and before ponding exceeds six (6) inch depth except when on pavement detention is occurring.

#### SUBSECTION 3.02.08.04 | CURB INLETS ON-GRADE

The sizing of curb inlets on-grade shall be done based on the equations and figures listed below, which are provided as references for *On-Grade Curb Inlet Capacities on the City Thoroughfares*.

#### EQUATIONS

- [EQUATION 3.10](#)
- [EQUATION 3.11](#)
- [EQUATION 3.12](#)
- [EQUATION 3.13](#)
- [EQUATION 3.14](#)
- [EQUATION 3.15](#)
- [EQUATION 3.16](#)
- [EQUATION 3.17](#)
- [EQUATION 3.18](#)

#### FIGURES

- [FIGURE 3.3](#)
- [FIGURE 3.4](#)
- [FIGURE 3.5](#)
- [FIGURE 3.6](#)
- [FIGURE 3.7](#)
- [FIGURE 3.8](#)
- [FIGURE 3.9](#)



### EQUATION 3.10: LENGTH OF CURB INLET ON GRADE REQUIRED

$$L_r = 0.6Q^{0.42}S^{0.3} \left( \frac{1}{nS_e} \right)^{0.6}$$

#### WHERE

$L_r$  = LENGTH OF CURB INLET REQUIRED (FEET)

$Q$  = FLOW RATE IN GUTTER (CFS)

$S$  = LONGITUDINAL SLOPE (FEET/FEET)

$n$  = MANNING'S ROUGHNESS COEFFICIENT, VALUE = 0.0175

$S_e$  = EQUIVALENT CROSS SLOPE (FEET/FEET)

### EQUATION 3.11: EQUIVALENT CROSS SLOPE

$$S_e = S_x + \frac{a}{W} E_0$$

#### WHERE

$S_e$  = EQUIVALENT CROSS SLOPE (FEET/FEET)

$S_x$  = CROSS SLOPE OF THE ROAD (FEET/FEET)

$a$  = GUTTER DEPRESSION DEPTH (FEET), ALL INLET DEPRESSIONS SHALL BE 0.50 FEET (6 INCHES)

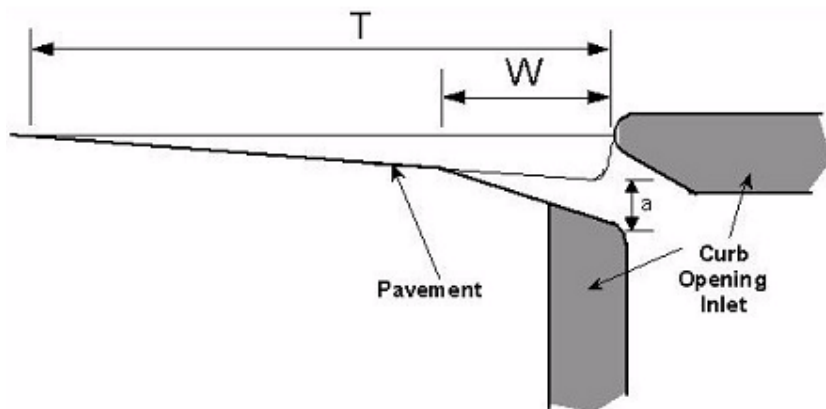
$W$  = GUTTER DEPRESSION WIDTH (FEET)

STANDARD INLETS  $W$  = 2.0 FEET

RECESSED INLETS  $W$  = 3.0 FEET

$E_0$  = RATIO OF DEPRESSION FLOW TO TOTAL FLOW

### FIGURE 3.3: GUTTER CROSS-SECTION DIAGRAM OF CURB INLETS ON GRADE



### EQUATION 3.12: RATIO OF DEPRESSION FLOW TO TOTAL FLOW OF CURB INLETS ON GRADE

$$E_0 = \frac{K_w}{K_w + K_0}$$

#### WHERE

$E_0$  = RATIO OF DEPRESSION FLOW TO TOTAL FLOW

$K_w$  = CONVEYANCE OF THE DEPRESSED GUTTER SECTION (CFS)

$K_0$  = CONVEYANCE OF THE GUTTER SECTION BEYOND THE DEPRESSION (CFS)

### EQUATION 3.13: CONVEYANCE OF CROSS SECTION OF CURB INLETS ON GRADE

$$K = \frac{1.486A^{5/3}}{nP^{2/3}}$$

#### WHERE

$K$  = CONVEYANCE OF CROSS SECTION (CFS)

$A$  = AREA OF CROSS SECTION (FEET<sup>2</sup>)





$n$  = MANNING'S ROUGHNESS COEFFICIENT, VALUE = 0.0175

$P$  = WETTED PERIMETER (FEET)

#### EQUATION 3.14: AREA OF DEPRESSED GUTTER SECTION OF CURB INLETS ON GRADE

$$A_w = WS_x \left( T - \frac{W}{2} \right) + \frac{1}{2} aW$$

##### WHERE

$A_w$  = AREA OF DEPRESSED GUTTER SECTION (FEET<sup>2</sup>)

$W$  = GUTTER DEPRESSION WIDTH (FEET)

STANDARD INLETS  $W$  = 2.0 FEET

RECESSED INLETS  $W$  = 3.0 FEET

$S_x$  = CROSS SLOPE (FEET/FEET)

$T$  = CALCULATED PONDED WIDTH (FT)

$a$  = GUTTER DEPRESSION DEPTH (FT), ALL INLET DEPRESSIONS SHALL BE 0.50 FEET (6 INCHES)

#### EQUATION 3.15: WETTED PERIMETER OF DEPRESSED GUTTER SECTION OF CURB INLETS ON GRADE

$$P_w = \sqrt{(WS_x + a)^2 + W^2}$$

##### WHERE

$P_w$  = WETTED PERIMETER OF DEPRESSED GUTTER SECTION (FEET)

$W$  = GUTTER DEPRESSION WIDTH (FEET)

STANDARD INLETS  $W$  = 2.0 FEET

RECESSED INLETS  $W$  = 3.0 FEET

$S_x$  = CROSS SLOPE (FEET/FEET)

$a$  = GUTTER DEPRESSION DEPTH (FEET), ALL INLET DEPRESSIONS SHALL BE 0.50 FEET (6 INCHES)

#### EQUATION 3.16: AREA OF GUTTER/ROAD SECTION BEYOND THE DEPRESSION WIDTH OF CURB INLETS ON GRADE

$$A_0 = \frac{S_x}{2} (T - W)^2$$

##### WHERE

$A_0$  = AREA OF GUTTER/ROAD SECTION BEYOND THE DEPRESSION WIDTH (FEET<sup>2</sup>)

$S_x$  = CROSS SLOPE (FEET/FEET)

$W$  = GUTTER DEPRESSION WIDTH (FEET)

STANDARD INLETS  $W$  = 2.0 FEET

RECESSED INLETS  $W$  = 3.0 FEET

$T$  = CALCULATED PONDED WIDTH

#### EQUATION 3.17: WETTED PERIMETER OF THE DEPRESSED GUTTER SECTION OF CURB INLETS ON GRADE

$$P_0 = T - W$$

##### WHERE

$P_0$  = WETTED PERIMETER OF THE DEPRESSED GUTTER SECTION (FEET)

$T$  = CALCULATED PONDED WIDTH (FEET)

$W$  = GUTTER DEPRESSION WIDTH (FEET)

STANDARD INLETS  $W$  = 2.0 FEET

RECESSED INLETS  $W$  = 3.0 FEET

For determining the bypass of a curb inlet on grade use the following [EQUATION 3.18](#) which factors in the ratio of the actual length of curb inlet ( $L_a$ ) to the length of inlet required ( $L_r$ ).



**EQUATION 3.18: CARRYOVER DISCHARGE OF CURB INLETS ON GRADE**

$$Q_{bypass} = Q \left( 1 - \frac{L_a}{L_r} \right)^{1.8}$$

**WHERE**

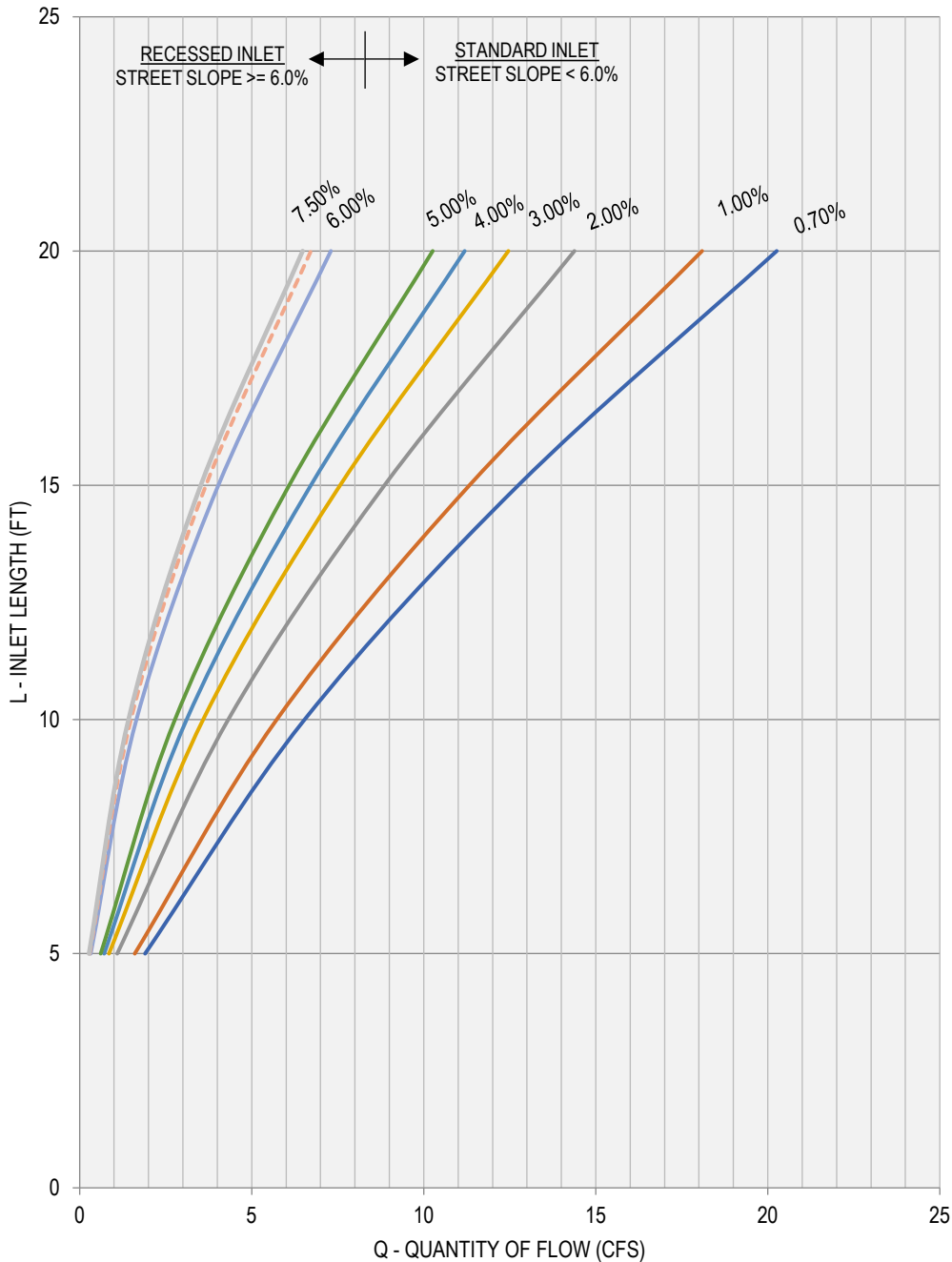
$Q_{bypass}$  = CARRYOVER DISCHARGE (CFS)

Q = TOTAL DISCHARGE (CFS)

$L_a$  = DESIGN LENGTH OF THE CURB OPENING INLET (FEET)

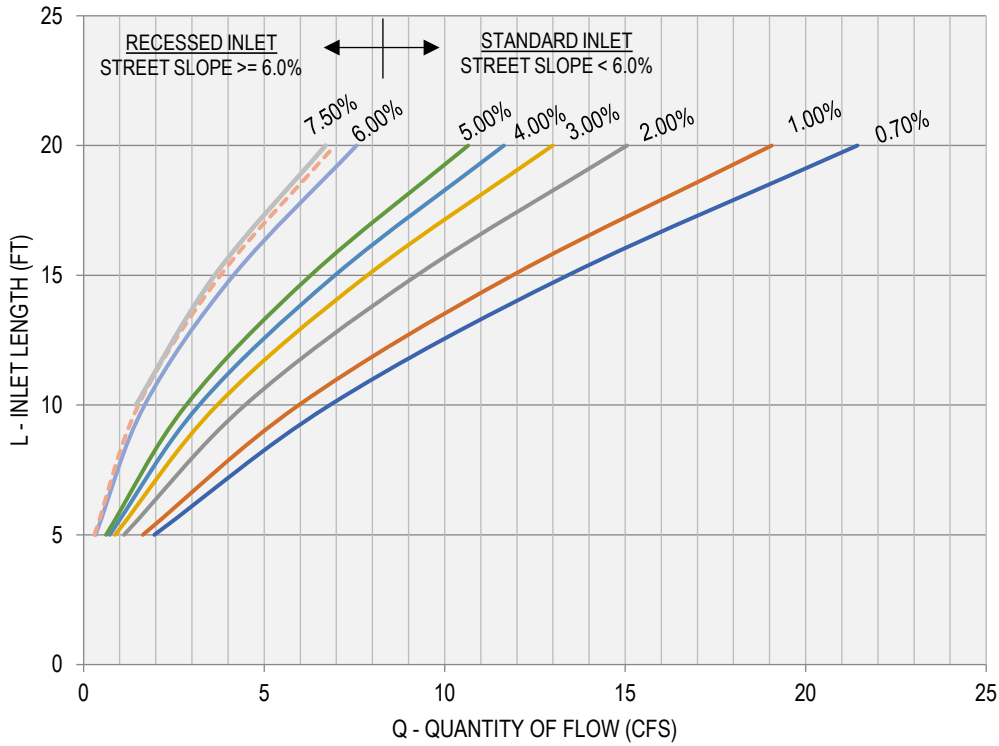
$L_r$  = LENGTH OF CURB OPENING INLET REQUIRED TO INTERCEPT THE TOTAL FLOW (FEET)

**FIGURE 3.4: CURB INLET CAPACITY ON-GRADE PRINCIPAL AND MINOR ARTERIAL (P6D & A4D)**



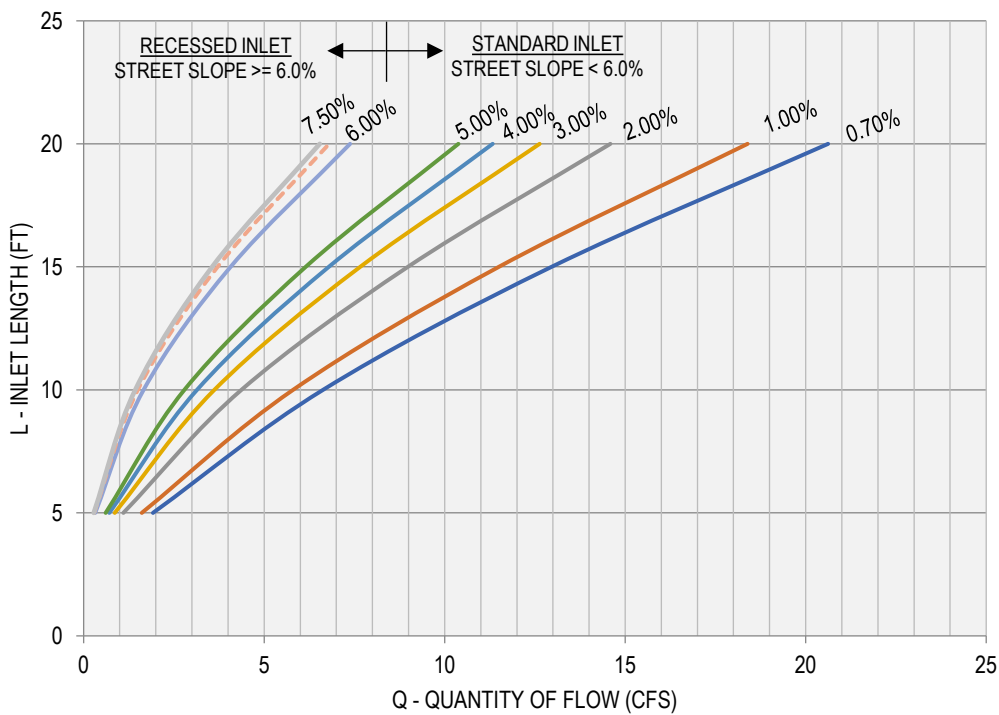
Inlet Capacity (cfs)				
Slope (%)	Inlet Length (ft)			
	5	10	15	20
0.70%	1.90	6.54	12.75	20.26
1.00%	1.60	5.73	11.33	18.09
2.00%	1.09	4.32	8.86	14.38
3.00%	0.85	3.59	7.57	12.46
4.00%	0.71	3.11	6.72	11.19
5.00%	0.61	2.77	6.09	10.26
6.00%	0.32	1.65	4.03	7.30
7.00%	0.29	1.49	3.67	6.72
7.50%	0.27	1.42	3.52	6.48

**FIGURE 3.5: CURB INLET CAPACITY ON-GRADE MAJOR COLLECTOR (M4U)**



Inlet Capacity (cfs)				
Slope (%)	Inlet Length (ft)			
	5	10	15	20
0.70%	1.96	6.82	13.41	21.43
1.00%	1.64	5.96	11.88	19.06
2.00%	1.12	4.47	9.23	15.05
3.00%	0.87	3.70	7.86	12.99
4.00%	0.72	3.20	6.96	11.64
5.00%	0.62	2.84	6.29	10.65
6.00%	0.33	1.69	4.15	7.56
7.00%	0.30	1.52	3.79	6.96
7.50%		1.45	3.63	6.70

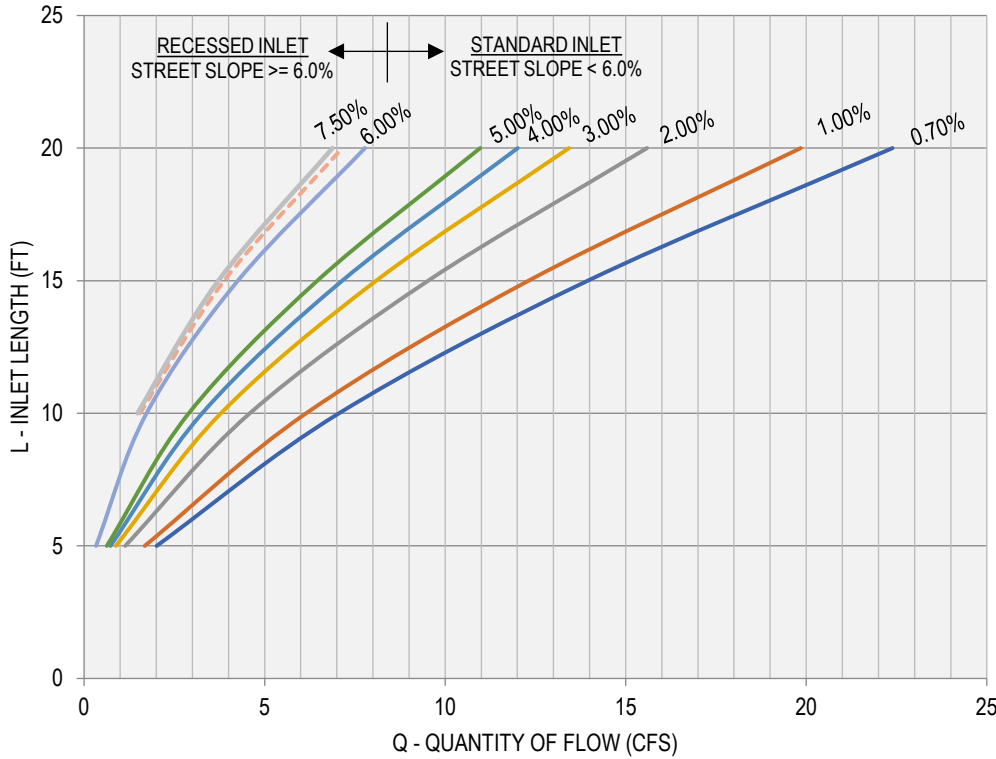
**FIGURE 3.6: CURB INLET CAPACITY ON-GRADE COLLECTION TWO (2) LANE WITH CONTINUOUS LEFT (M3U)**



Inlet Capacity (cfs)				
Slope (%)	Inlet Length (ft)			
	5	10	15	20
0.70%	1.92	6.63	12.96	20.62
1.00%	1.61	5.80	11.50	18.39
2.00%	1.10	4.37	8.98	14.59
3.00%	0.86	3.62	7.66	12.63
4.00%	0.71	3.14	6.79	11.33
5.00%	0.61	2.79	6.15	10.38
6.00%	0.32	1.66	4.07	7.38
7.00%	0.29	1.50	3.71	6.80
7.50%	0.28	1.43	3.56	6.54

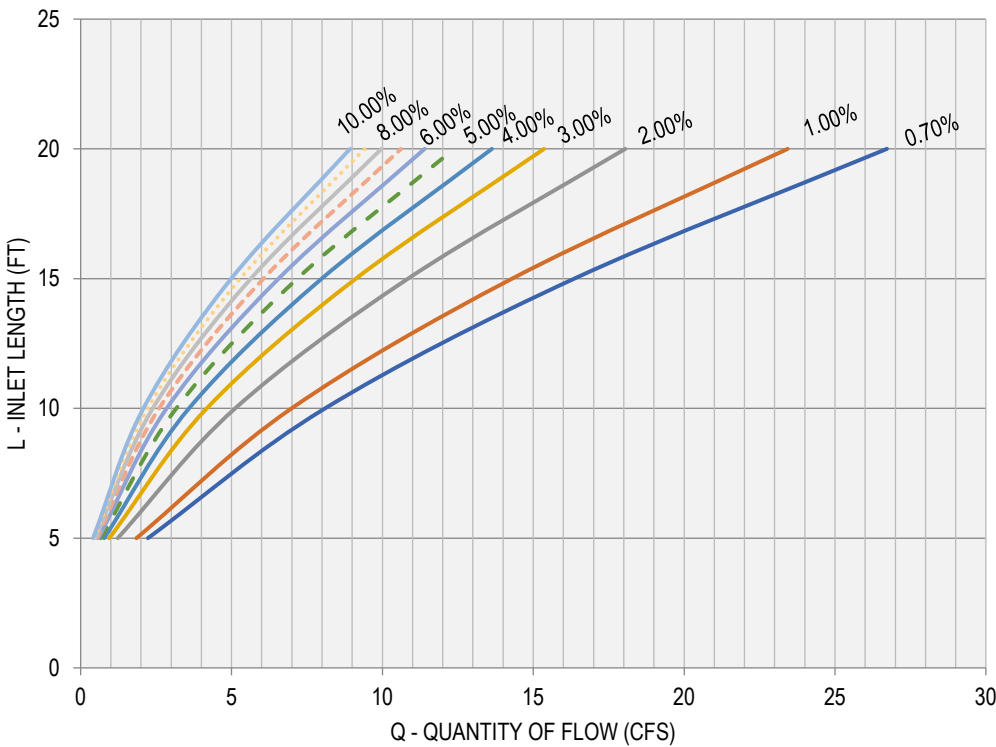


**FIGURE 3.7: CURB INLET CAPACITY ON-GRADE MINOR COLLECTOR**



Inlet Capacity (cfs)				
Slope (%)	Inlet Length (ft)			
	5	10	15	20
0.70%	2.01	7.06	13.95	22.39
1.00%	1.68	6.15	12.31	19.85
2.00%	1.14	4.59	9.53	15.59
3.00%	0.88	3.79	8.09	13.43
4.00%	0.73	3.27	7.15	12.01
5.00%	0.63	2.90	6.46	10.97
6.00%	0.33	1.73	4.26	7.78
7.00%		1.55	3.88	7.15
7.50%		1.48	3.72	6.88

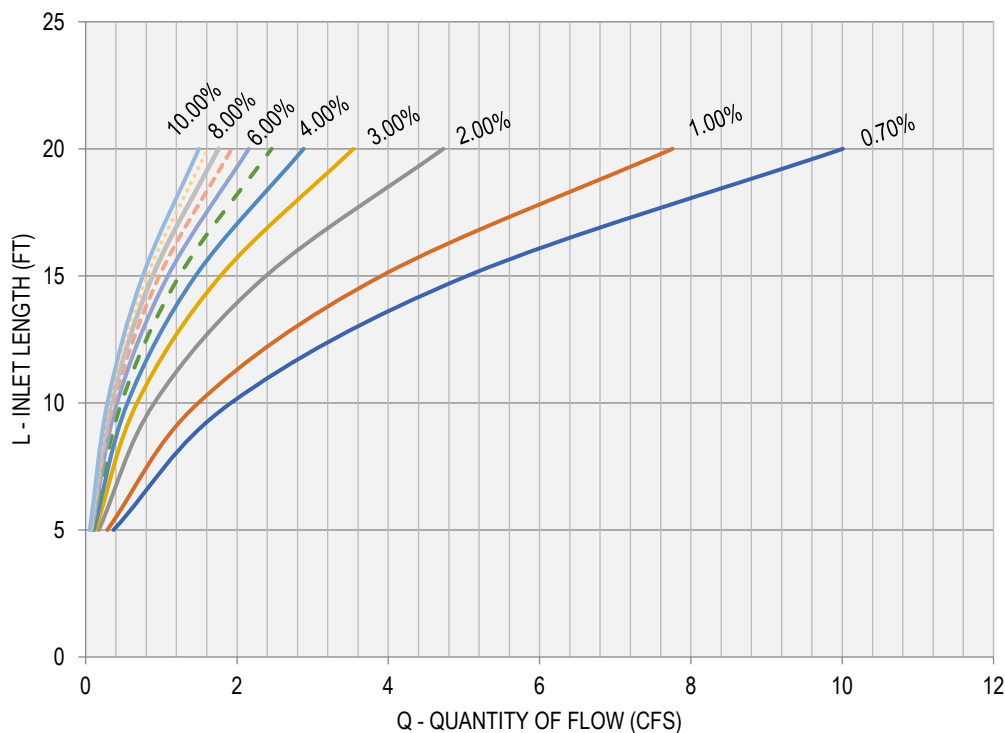
**FIGURE 3.8: CURB INLET CAPACITY ON-GRADE LOCAL RESIDENTIAL STREET**



Inlet Capacity (cfs)				
Slope (%)	Inlet Length (ft)			
	5	10	15	20
0.70%	2.23	8.10	16.36	26.72
1.00%	1.85	6.99	14.30	23.43
2.00%	1.23	5.12	10.85	18.05
3.00%	0.95	4.18	9.12	15.36
4.00%	0.78	3.59	7.99	13.63
5.00%	0.67	3.17	7.18	12.38
6.00%	0.59	2.85	6.56	11.40
7.00%	0.53	2.60	6.06	10.62
8.00%	0.48	2.39	5.64	9.97
9.00%	0.44	2.22	5.29	9.41
10.00%	0.41	2.08	4.99	8.93



**FIGURE 3.9: CURB INLET CAPACITY ON-GRADE ALLEY**



Slope (%)	Inlet Capacity (cfs)			
	Inlet Length (ft)			
	5	10	15	20
0.70%	0.37	1.92	5.05	10.01
1.00%	0.29	1.49	3.91	7.76
2.00%	0.17	0.91	2.38	4.73
3.00%	0.13	0.68	1.78	3.54
4.00%	0.11	0.55	1.45	2.88
5.00%	0.09	0.47	1.24	2.46
6.00%	0.08	0.41	1.09	2.16
7.00%	0.07	0.37	0.97	1.93
8.00%	0.06	0.34	0.89	1.76
9.00%	0.06	0.31	0.81	1.61
10.00%	0.06	0.29	0.76	1.50

**SUBSECTION 3.02.08.05 | CURB INLETS AT SAG/LOW POINT**

Determining the capacity of curb inlets at sag/low point shall be taken from [EQUATION 3.19](#) while the inlet operates as a weir until the water depth approaches 1.40 times the curb opening height.

**EQUATION 3.19: CAPACITY OF CURB INLETS AT SAG/LOW POINT**

$$Q = 2.3(L + 1.8W)y^{1.5}$$

**WHERE**

Q = TOTAL FLOW REACHING INLET (CFS)

y = DEPTH OF FLOW (FEET)

L = LENGTH OF CURB INLET OPENING (FEET)

W = GUTTER DEPRESSION WIDTH (FEET)

STANDARD INLETS W = 2.0 FEET

RECESSED INLETS W = 3.0 FEET

[EQUATION 3.19](#) can be rearranged to find the required curb inlet length at a sag point as shown in [EQUATION 3.20](#).

**EQUATION 3.20: REQUIRED CURB INLET LENGTH AT A SAG POINT**

$$L = \frac{Q}{2.3y^{1.5}} - 1.8W$$

**WHERE**

Q = TOTAL FLOW REACHING INLET (CFS)

y = DEPTH OF FLOW (FEET)

L = LENGTH OF CURB INLET OPENING (FEET)

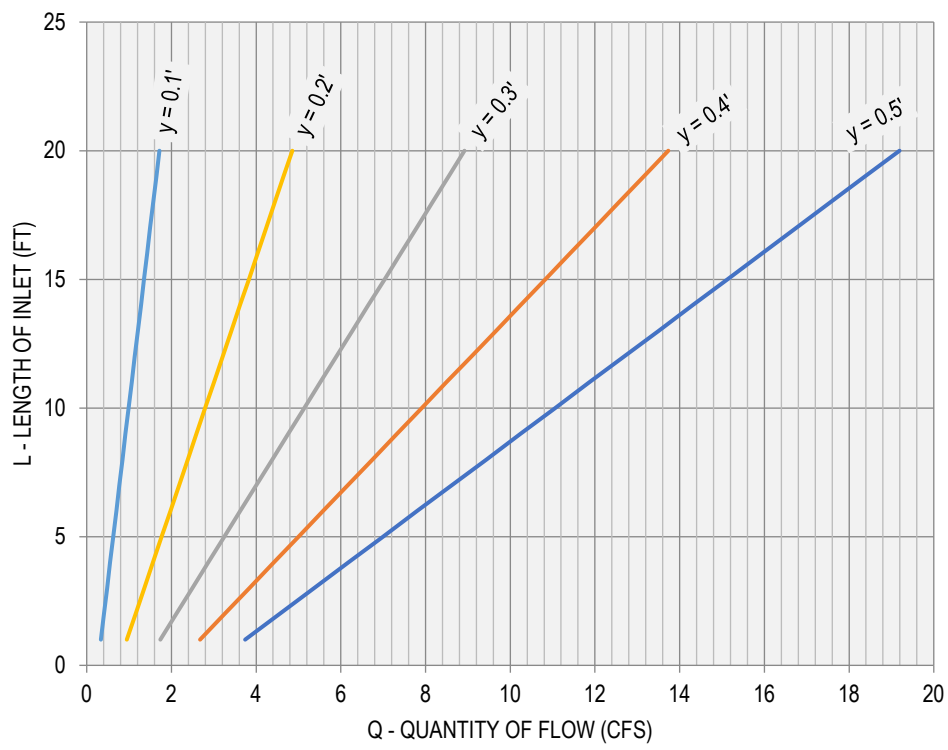
W = GUTTER DEPRESSION WIDTH (FEET)

STANDARD INLETS W = 2.0 FEET

RECESSED INLETS W = 3.0 FEET

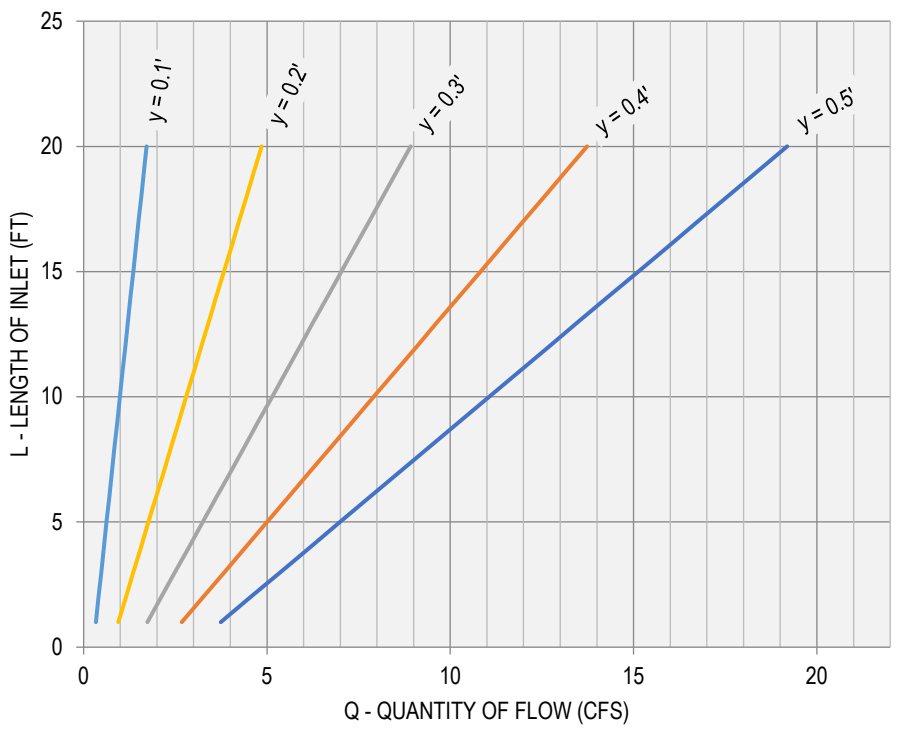
FIGURES 3.10 and FIGURES 3.11 are provided as reference for Standard and Recessed Sag Curb Inlet Capacities.

**FIGURE 3.10: STANDARD CURB INLET CAPACITY SAG/LOW**



Inlet Capacity (cfs)					
Length of Inlet, L (ft)	Depth of flow, y (ft)				
	0.50	0.40	0.30	0.20	0.10
5	6.99	5.00	3.25	1.77	0.63
10	11.06	7.91	5.14	2.80	0.99
15	15.13	10.82	7.03	3.83	1.35
20	19.19	13.73	8.92	4.85	1.72

**FIGURE 3.11: RECESSED CURB INLET CAPACITY SAG/LOW POINT**



Inlet Capacity (cfs)					
Length of Inlet, L (ft)	Depth of flow, y (ft)				
	0.50	0.40	0.30	0.20	0.10
5	8.46	6.05	3.93	2.14	0.76
10	12.52	8.96	5.82	3.17	1.12
15	16.59	11.87	7.71	4.20	1.48
20	20.65	14.78	9.60	5.23	1.85

**SUBSECTION 3.02.09 | DROP INLETS/'Y' INLET DESIGN**

The capacity of drop inlets shall be taken from the [EQUATION 3.21](#). All drop inlets shall be sized to have a maximum allowable head (depth of water) on the inlet to be six (6) inches.

**EQUATION 3.21: CAPACITY OF DROP INLETS**

$$Q = 3.087Ly^{3/2}$$

**WHERE**

- Q = FLOW TO INLET (CFS)
- L = LENGTH OF INLET OPENING (FT)
- y = DEPTH OF WATER (HEAD) AT INLET (FT)

The equation can be rearranged to find the length of Drop Inlet opening as shown in [EQUATION 3.22](#).

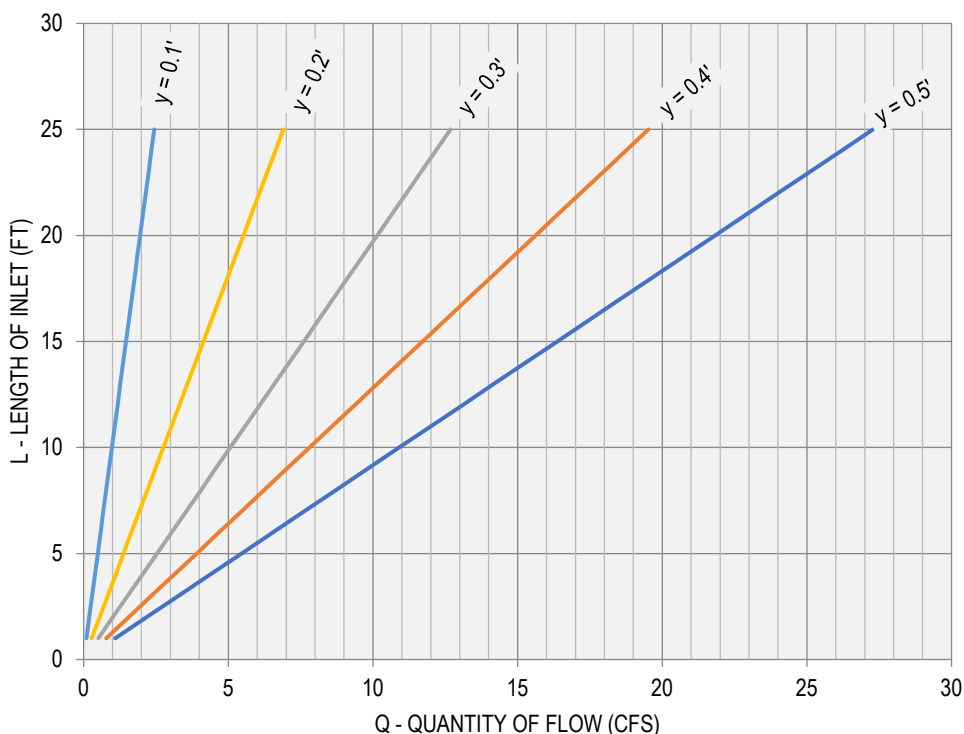
**EQUATION 3.22: LENGTH OF DROP INLET OPENING**

$$L = \frac{Q}{3.087y^{3/2}}$$

**WHERE**

- Q = FLOW TO INLET OPENING (CFS)
- L = LENGTH OF INLET OPENING (FT)
- y = DEPTH OF WATER (HEAD) AT INLET (FT)

**FIGURE 3.12: DROP/'Y' INLET CAPACITY**



Length of Inlet, L (ft)	Inlet Capacity (cfs)				
	0.50	0.40	0.30	0.20	0.10
2'x2', L = 8'	8.73	6.25	4.06	2.21	0.78
3'x3', L = 12'	13.10	9.37	6.09	3.31	1.17
4'x4', L = 16'	17.46	12.50	8.12	4.42	1.56
5'x5', L = 20'	21.83	15.62	10.14	5.52	1.95

**SUBSECTION 3.02.10 | COMBINATION AND GRATE INLET DESIGN**

When allowed by the City Engineer combination and grate Inlets shall be sized using [FIGURE 3.13](#), [FIGURE 3.14](#), [FIGURE 3.15](#), [FIGURE 3.16](#), [FIGURE 3.17](#), [FIGURE 3.18](#), [FIGURE 3.19](#), and [FIGURE 3.20](#).

**FORM 3.2: INLET DESIGN CALCULATIONS TABLE**

INLET ID	LOCATION			DESIGN FREQUENCY	AREA RUNOFF						UPSTREAM BYPASS (C*A)
	ALIGNMENT	STATION	OFFSET		C	AREA ID	TIME OF CONCENTRATION (T <sub>c</sub> )	INTENSITY (I)	AREA (A)	RUN OFF (Q)	
				YEAR			MINUTES	INCHES/HOUR	ACRES	CFS	CFS
(1)	(2)	(3)	(4)	(5)	(6)	(7)	(8)	(9)	(10)	(11)	(12)

TOTAL GUTTER FLOW (Q <sub>a</sub> )	GUTTER FLOW									
	THOROUGHFARE TYPE	ON-GRADE/SAG	MANNING'S (n)	LONG SLOPE (S)	CROWN TYPE	CROSS SLOPE (S <sub>x</sub> )	DEPRESSION		PONDING WIDTH/SPREAD	
							DEPTH (a)	WIDTH (W)	ALLOW (T <sub>ALLOW</sub> )	ACTUAL (T <sub>ACTUAL</sub> )
CFS				FEET/FEET		FEET/FEET	FEET	FEET	FEET	FEET
(13)	(14)	(15)	(16)	(17)	(18)	(19)	(20)	(21)	(22)	(23)

GUTTER FLOW			INLETS CAPACITY							
DEPTH OF GUTTER		MAXIMUM ALLOWABLE FLOW BASED ON MAXIMUM ALLOWABLE PONDING WIDTH (Q <sub>ALLOW GUTTER</sub> )	DEPRESSED GUTTER SECTION		SECTION BEYOND DEPRESSION		CONVEYANCE		RATIO OF DEPRESSION FLOW TO TOTAL FLOW (E <sub>0</sub> )	EQUIVALENT CROSS-SLOPE (S <sub>e</sub> )
ALLOW (Y <sub>ALLOW</sub> )	ACTUAL (Y <sub>ACTUAL</sub> )		AREA (A <sub>w</sub> )	WETTED PERIMETER (P <sub>w</sub> )	AREA (A <sub>0</sub> )	WETTED PERIMETER (P <sub>0</sub> )	DEPRESSION SECTION (K <sub>w</sub> )	SECTION BEYOND DEPRESSION (K <sub>0</sub> )		
FEET	FEET	CFS	FEET <sup>2</sup>	FEET	FEET <sup>2</sup>	FEET	CFS	CFS		FEET/FEET
(24)	(25)	(26)	(27)	(28)	(29)	(30)	(31)	(32)	(33)	(34)

INLETS CAPACITY		INLETS CAPACITY				REMARKS
INLET LENGTH		INLET CAPACITY (Q <sub>c</sub> )	FLOW (Q <sub>BYPASS</sub> )	C*A	TO INLET ID	
REQUIRED (L <sub>REQUIRED</sub> )	ACTUAL (L <sub>ACTUAL</sub> )					
FEET	FEET	CFS	CFS	CFS		
(35)	(36)	(37)	(38)	(39)	(40)	(41)





## INSTRUCTIONS FOR FORM 3.2: INLET DESIGN CALCULATIONS

COLUMN (1)	INLET NUMBER OR DESIGNATION, STARTING WITH THE MOST UPSTREAM INLET.
COLUMN (2)	STREET ALIGNMENT/ NAME IN WHICH THE INLET IS LOCATED.
COLUMN (3)	STATION ALONG THE ALIGNMENT IN WHICH THE INLET IS LOCATED.
COLUMN (4)	OFFSET DISTANCE AND SIDE (RT/LT) INLET IS LOCATED.
COLUMN (5)	DESIGN STORM FREQUENCY, SHALL BE 100-YR FOR ALL INLETS.
COLUMN (6)	RUNOFF COEFFICIENT TAKEN FROM <a href="#">TABLE 3.2</a> .
COLUMN (7)	CONTRIBUTING DRAINAGE AREA ID.
COLUMN (8)	MINIMUM INLET TIME OF CONCENTRATION TAKEN FROM <a href="#">TABLE 3.3</a> .
COLUMN (9)	USING THE TIME OF CONCENTRATION AND DESIGN STORM FREQUENCY, THE RAINFALL INTENSITY IS TAKEN FROM FIGURE 3.1.
COLUMN (10)	RUNOFF AREA TO INLET IN ACRES.
COLUMN (11)	SOLUTION OF <a href="#">EQUATION 3.1</a> .
COLUMN (12)	TAKEN FROM COLUMN (39) OF THE UPSTREAM INLET.
COLUMN (13)	$= \text{Column (9)} \left\{ \frac{\text{Column(12)} + \{\{\text{Column(6)} * \text{Column(10)}\}}}{\{\{\text{Column(6)} * \text{Column(10)}\}} \right\}$
COLUMN (14)	THOROUGHFARE TYPE TAKEN FROM <a href="#">SECTION 2, STREETS</a> , (P6D, A4D, M4U, M3U, MINOR COLLECTOR, LOCAL, ALLEY, PARKING).
COLUMN (15)	DETERMINED BY LOCATION OF INLET (ON-GRADE OR SAG).
COLUMN (16)	MANNING'S N VALUE.
COLUMN (17)	STREET LONGITUDINAL GUTTER SLOPE OF THE STREET TAKEN IN (FEET/FEET).
COLUMN (18)	STREET CROWN TYPE ON WHICH THE INLET IS LOCATED.
COLUMN (19)	STREET CROSS-SLOPE IN FEET/FEET.
COLUMN (20)	GUTTER DEPRESSION DEPTH, REFERENCE <a href="#">FIGURE 3.3</a> .
COLUMN (21)	GUTTER DEPRESSION WIDTH, REFERENCE <a href="#">FIGURE 3.3</a> .
COLUMN (22)	DETERMINED BY THE TYPE OF THOROUGHFARE IN THE PERMISSIBLE SPREAD WIDTH SECTION.
COLUMN (23)	SOLUTION OF <a href="#">EQUATION 3.9</a> .
COLUMN (24)	THE PRODUCT OF COLUMN (22) AND COLUMN (19).
COLUMN (25)	THE PRODUCT OF COLUMN (23) AND COLUMN (19).
COLUMN (26)	SOLUTION OF <a href="#">EQUATION 3.7</a> USING THE MAXIMUM ALLOWABLE POND WIDTH FROM COLUMN (22).



COLUMN (27)	SOLUTION OF <a href="#">EQUATION 3.14</a> .
COLUMN (28)	SOLUTION OF <a href="#">EQUATION 3.15</a> .
COLUMN (29)	SOLUTION OF <a href="#">EQUATION 3.16</a> .
COLUMN (30)	SOLUTION OF <a href="#">EQUATION 3.17</a> .
COLUMN (31)	SOLUTION OF <a href="#">EQUATION 3.13</a> USING COLUMNS (27) AND (28).
COLUMN (32)	SOLUTION OF <a href="#">EQUATION 3.13</a> USING COLUMNS (29) AND (30).
COLUMN (33)	SOLUTION OF <a href="#">EQUATION 3.12</a> .
COLUMN (34)	SOLUTION OF <a href="#">EQUATION 3.11</a> .
COLUMN (35)	SOLUTION OF <a href="#">EQUATION 3.10</a> FOR ON-GRADE CURB INLETS, <a href="#">EQUATION 3.20</a> FOR SAG CURB INLET, OR <a href="#">EQUATION 3.22</a> FOR DROP INLETS.
COLUMN (36)	SELECTED INLET SIZE.
COLUMN (37)	THE CAPACITY OF THE SELECTED INLET SIZE OF COLUMN (35), SOLUTION FOUND BY ITERATIVELY SOLVING FOR CAPACITY BASED ON <a href="#">EQUATION 3.10</a> FOR CURB INLETS, <a href="#">EQUATION 3.19</a> FOR SAG CURB INLETS, <a href="#">EQUATION 3.21</a> FOR DROP INLETS.
COLUMN (38)	FOR ON-GRADE INLETS THE SOLUTION OF <a href="#">EQUATION 3.18</a> .
COLUMN (39)	EQUAL COLUMN (38) DIVIDED BY COLUMN (9).
COLUMN (40)	NEXT DOWNSTREAM INLET TO WHICH BY THE BY-PASS IS GOING.
COLUMN (41)	SPECIAL DESIGN COMMENTS ARE ENTERED HERE.

**FIGURE 3.13: TWO (2) GRATE COMBINATION INLET CAPACITY CURVES ON GRADE**

**EXAMPLE**

**Known:**

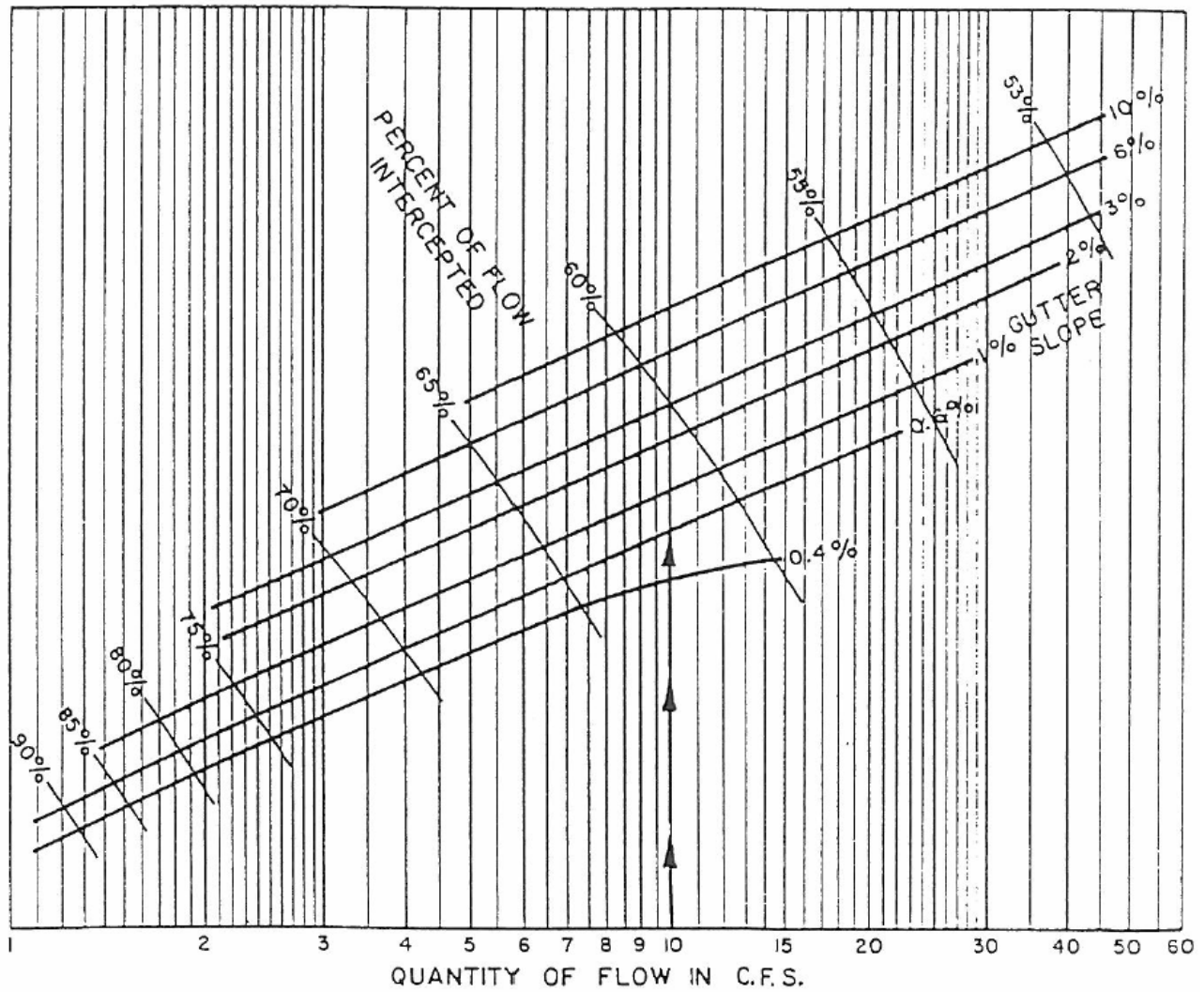
Quantity of Flow = 10.0 c.f.s.  
 Gutter Slope = 0.6 %

**Find:**

Capacity of Two Grate Combination Inlet

**Solution:**

Enter Graph at 10.0 c.f.s.  
 Intersect Slope = 0.6 %  
 Read Percent of Flow Intercepted = 62 %  
 62 % of 10.0 c.f.s. = 6.2 c.f.s.  
 as Capacity of Two Grate Combination Inlet  
 Remaining Gutter Flow =  
 10.0 c.f.s - 6.2 c.f.s. = 3.8 c.f.s.



**TWO GRATE COMBINATION INLET CAPACITY CURVES ON GRADE**



FIGURE 3.14: FOUR (4) GRATE COMBINATION INLET CAPACITY CURVES ON GRADE

**EXAMPLE**

**Known:**

Quantity of Flow = 6.0 c.f.s.

Gutter Slope = 1.0 %

**Find:**

Capacity of Four Grate Combination  
Inlet

**Solution:**

Enter Graph at 6.0 c.f.s.

Intersect Slope = 1.0 %

Read Percent of Flow

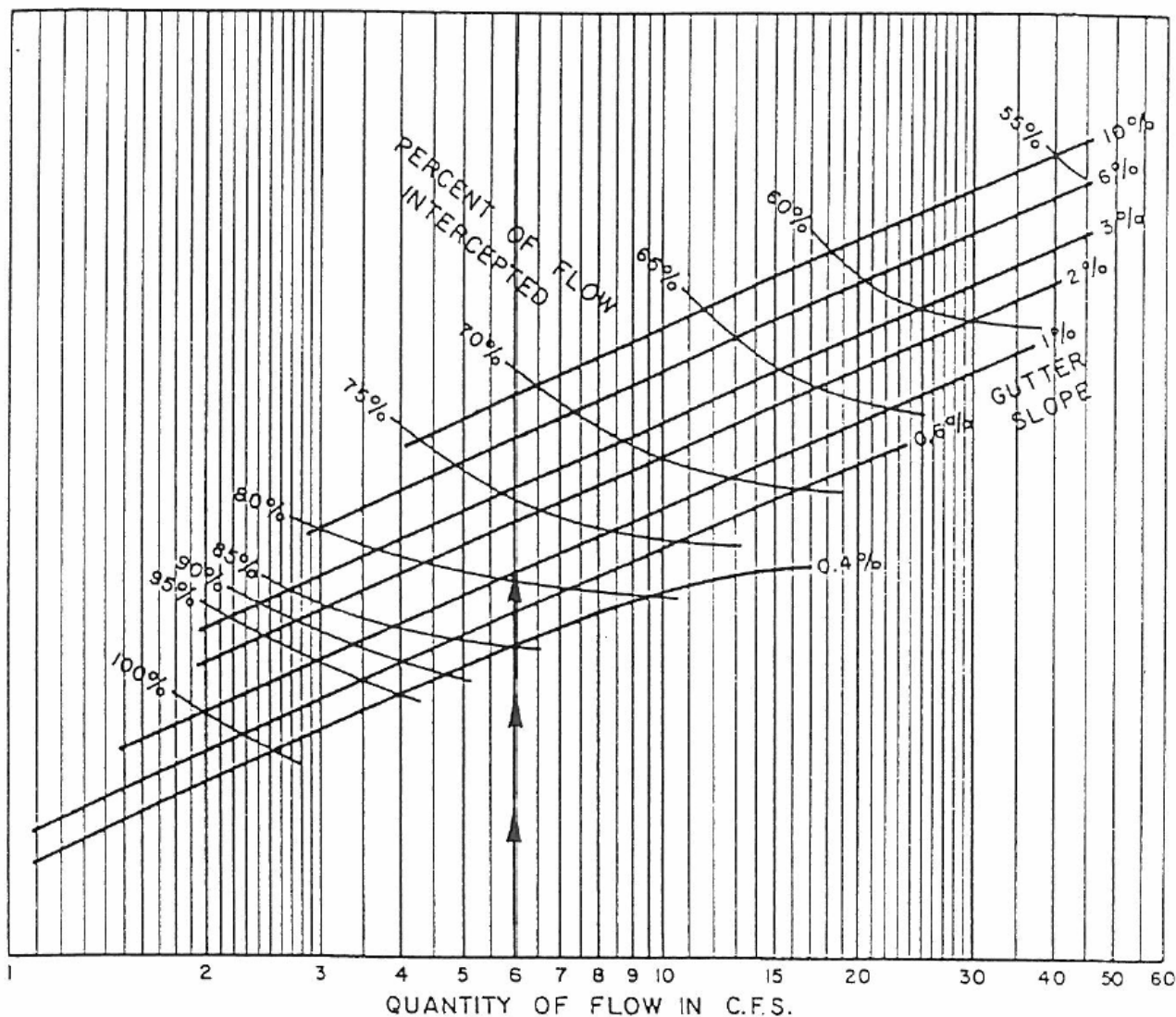
Intercepted = 79 %

79 % of 6.0 c.f.s. = 4.7 c.f.s.

as Capacity of Four Grate  
Combination Inlet

Remaining Gutter Flow =

6.0 c.f.s. - 4.7 c.f.s. = 1.3 c.f.s.



FOUR GRATE COMBINATION INLET  
CAPACITY CURVES  
ON GRADE



FIGURE 3.15: THREE (3) GRATE INLET AND THREE (3) GRATE COMBINATION INLET CAPACITY CURVES ON GRADE

**EXAMPLE**

**Known:**

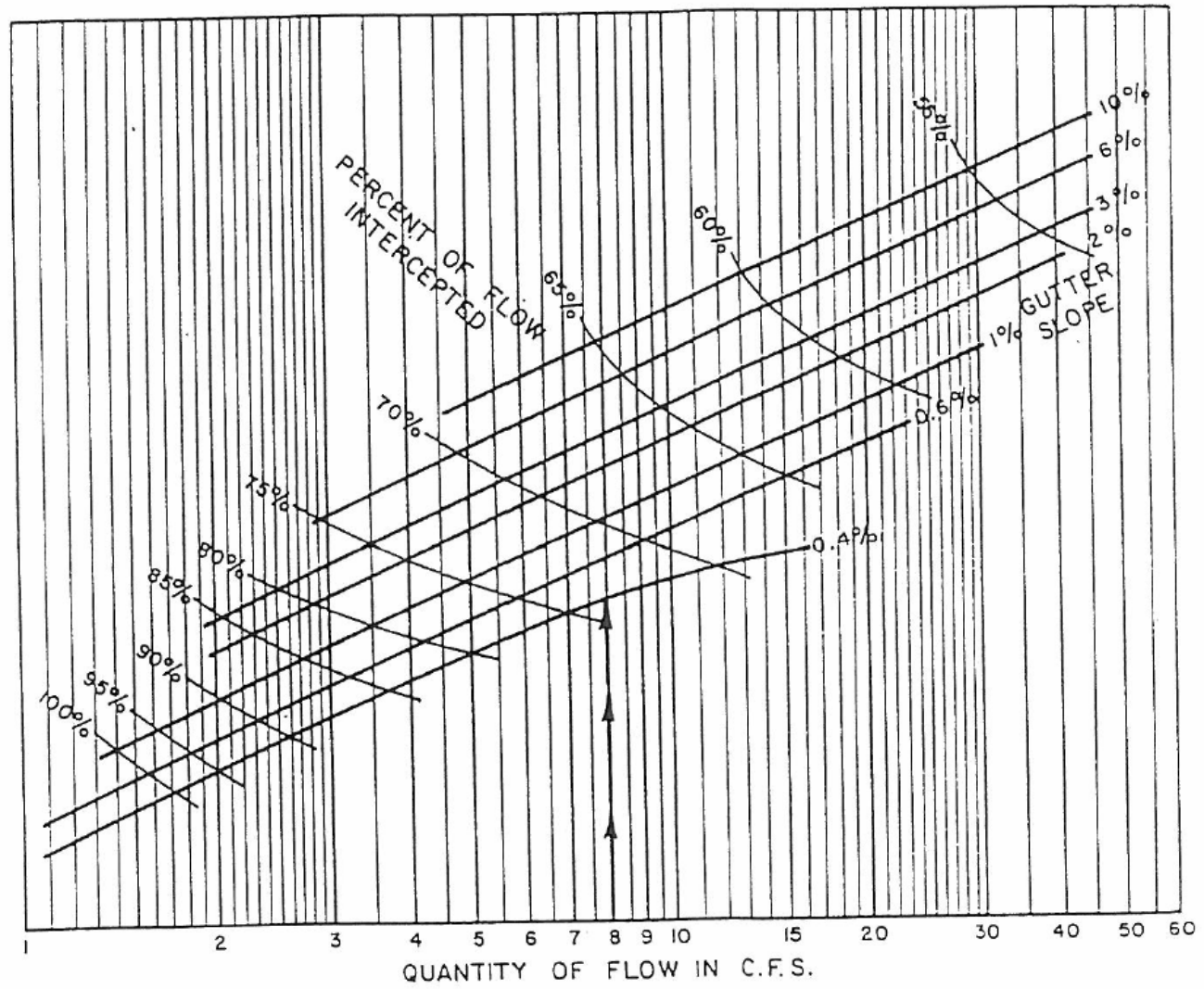
Quantity of Flow = 8.0 c.f.s.  
 Gutter Slope = 0.4%

**Find:**

Capacity of Three Grate Inlet

**Solution:**

Enter Graph at 8.0 c.f.s.  
 Intersect Slope = 0.4%  
 Read Percent of Flow Intercepted = 74%  
 74% of 8.0 c.f.s. = 5.9 c.f.s.  
 as Capacity of Three Grate Inlet  
 Remaining Gutter Flow =  
 8.0 c.f.s. - 5.9 c.f.s. = 2.1 c.f.s.



THREE GRATE INLET AND  
 THREE GRATE COMBINATION INLET  
 CAPACITY CURVES  
 ON GRADE

**FIGURE 3.16: TWO (2) GRATE INLET CAPACITY CURVES ON GRADE**

**EXAMPLE**

**Known:**

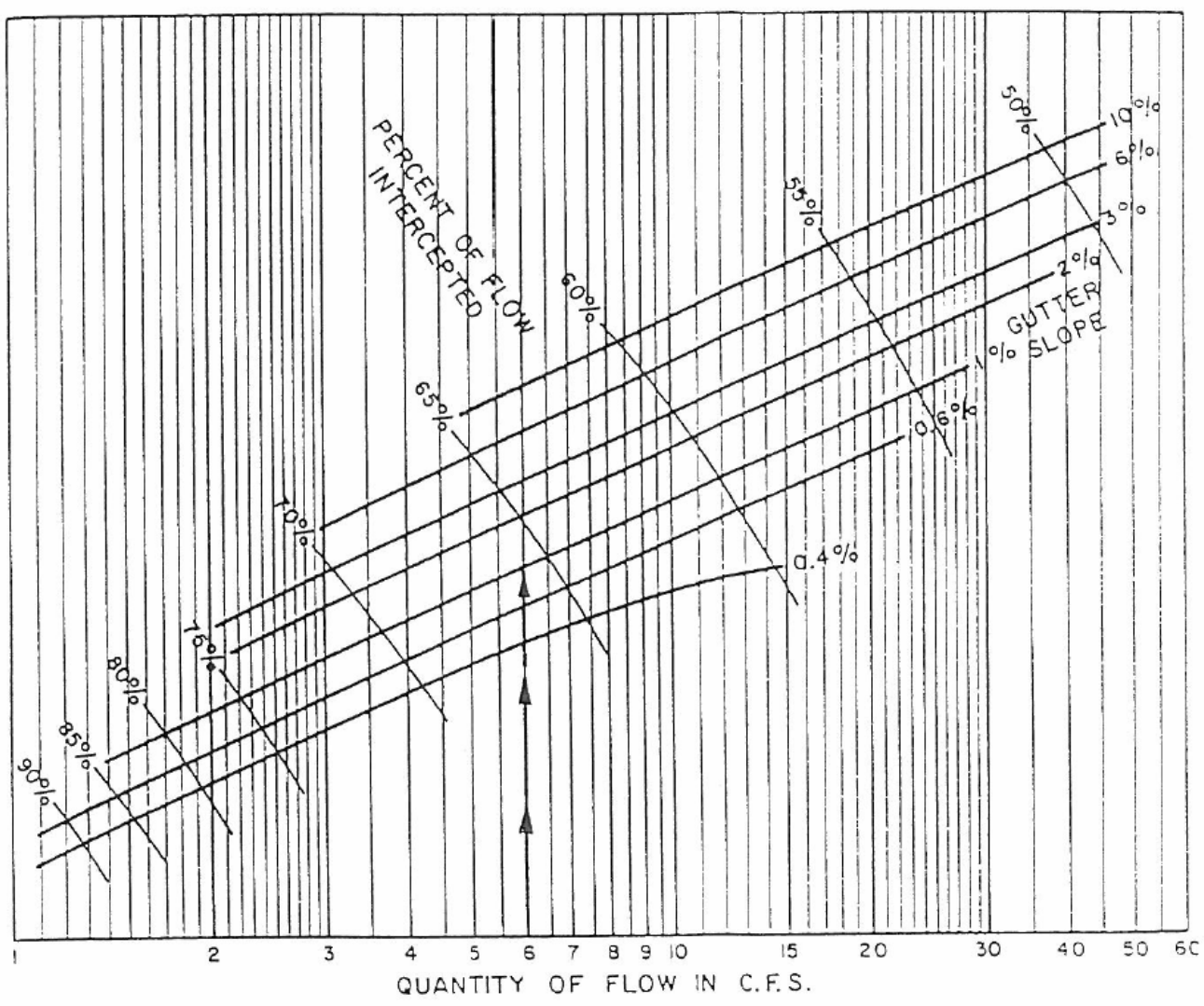
- Quantity of Flow = 6.0 c.f.s.
- Gutter Slope = 1.0%

**Find:**

Capacity of Two Grate Inlet

**Solution:**

- Enter Graph at 6.0 c.f.s.
- Intersect Slope = 1.0%
- Read Percent of Flow Intercepted = 66%
- 66% of 6.0 c.f.s. = 4.0 c.f.s.
- as Capacity of Two Grate Inlet
- Remaining Gutter Flow = 6.0 c.f.s. - 4.0 c.f.s. = 2.0 c.f.s.



**TWO GRATE INLET  
CAPACITY CURVES  
ON GRADE**



FIGURE 3.17: FOUR (4) GRATE INLET CAPACITY CURVES ON GRADE

EXAMPLE

Known:

Quantity of Flow = 6.0 c.f.s.

Gutter Slope = 1.0%

Find:

Capacity of Four Grate Inlet

Solution:

Enter Graph at 6.0 c.f.s.

Intersect Slope = 1.0%

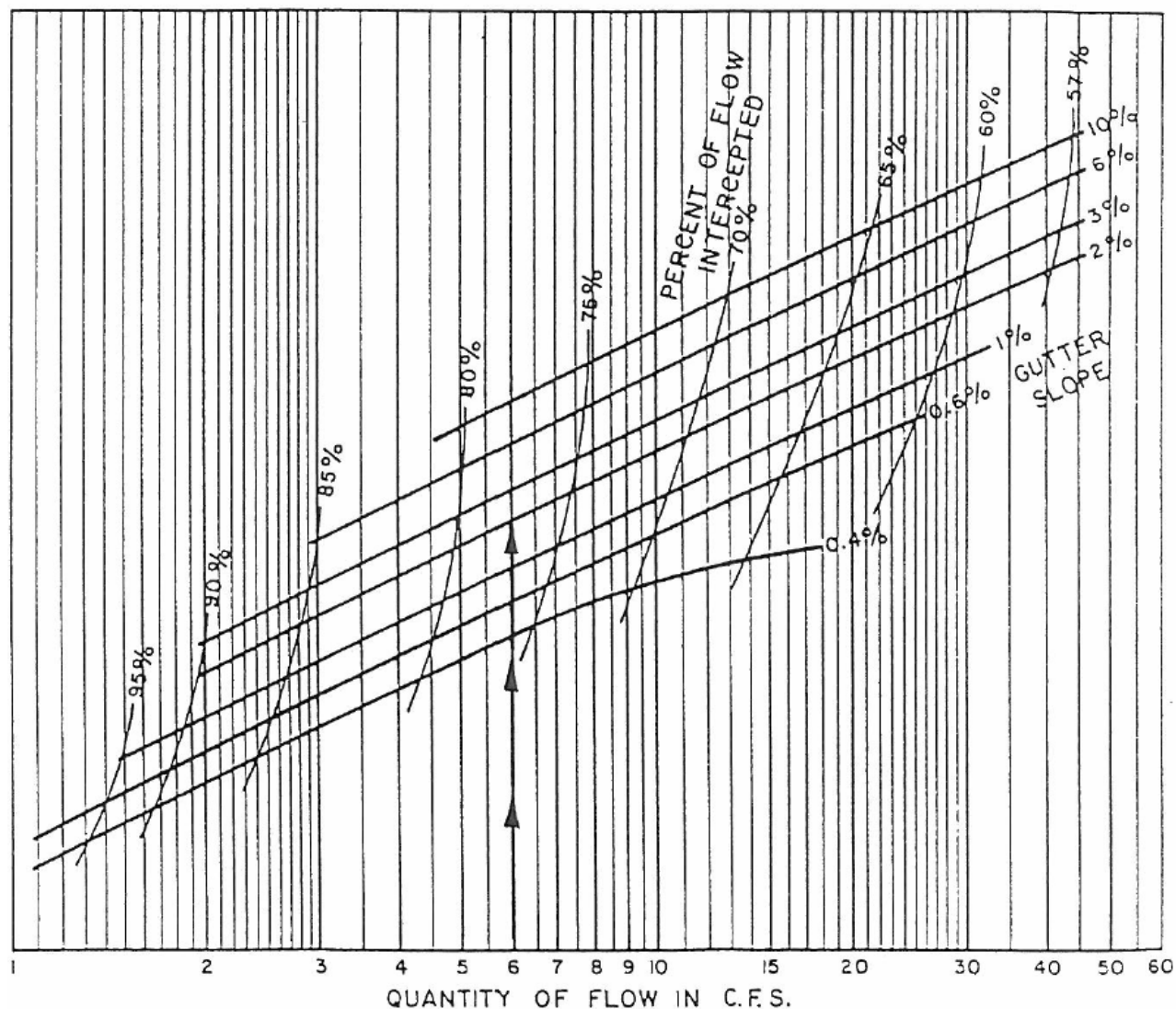
Read Percent of Flow Intercepted = 77%

77% of 6.0 c.f.s. = 4.6 c.f.s.

as Capacity of Four Grate Inlet

Remaining Gutter Flow =

6.0 c.f.s. - 4.6 c.f.s. = 1.4 c.f.s.



FOUR GRATE INLET  
CAPACITY CURVES  
ON GRADE

**FIGURE 3.18: SIX (6) GRATE INLET CAPACITY CURVES ON GRADE**

**EXAMPLE**

**Known:**

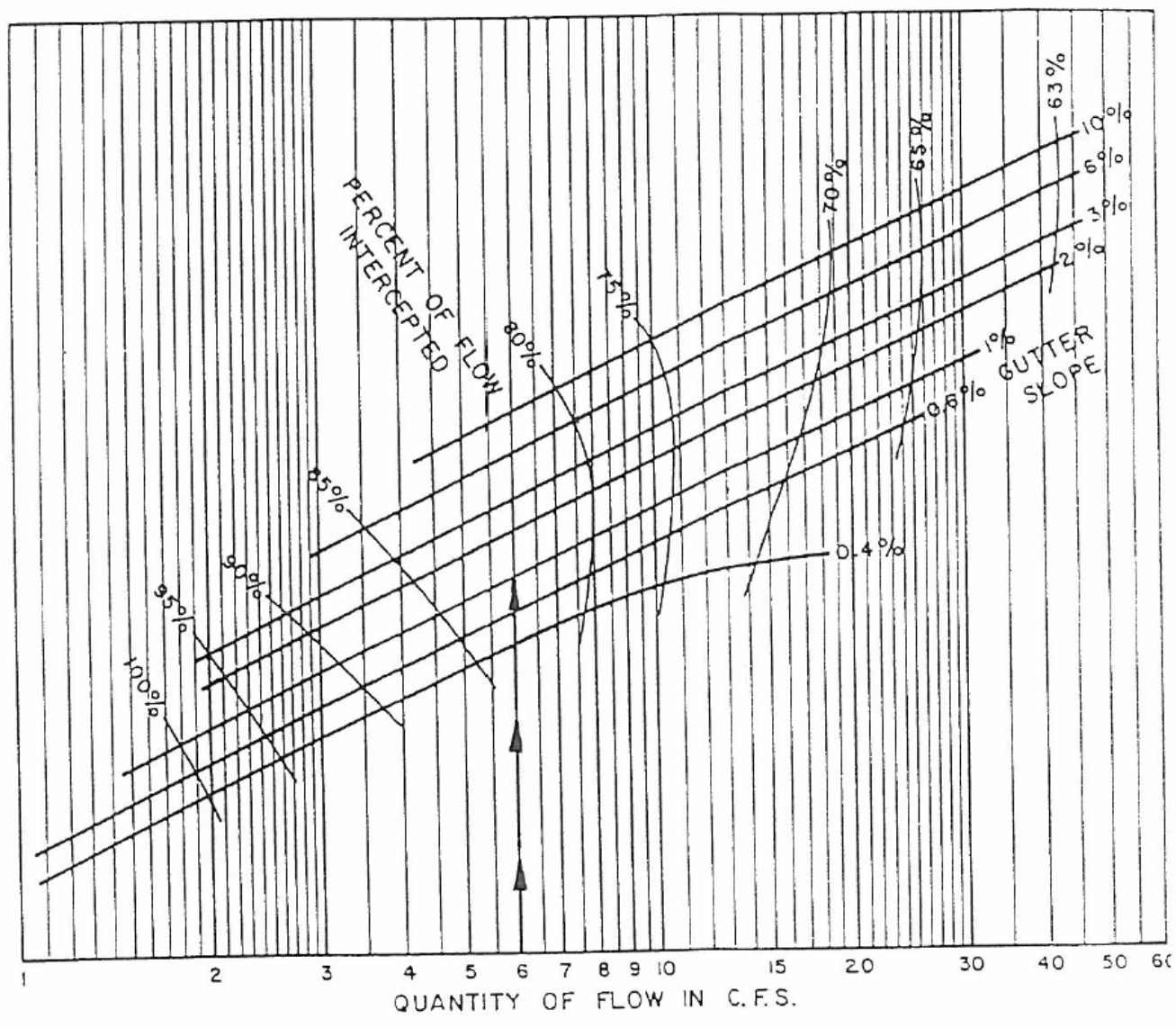
Quantity of Flow = 6.0 c.f.s.  
 Gutter Slope = 1.0%

**Find:**

Capacity of Six Grate Inlet

**Solution:**

Enter Graph at 6.0 c.f.s.  
 Intersect Slope = 1.0%  
 Read Percent of Flow Intercepted = 82 %  
 82 % of 6.0 c.f.s. = 4.9 c.f.s.  
 as Capacity of Six Grate Inlet  
 Remaining Gutter Flow =  
 6.0c.f.s. - 4.9 c.f.s. = 1.1 c.f.s.



**SIX GRATE INLET  
 CAPACITY CURVES  
 ON GRADE**



FIGURE 3.19: GRATE INLET CAPACITY CURVES AT LOW POINT

**EXAMPLE**

**Known:**

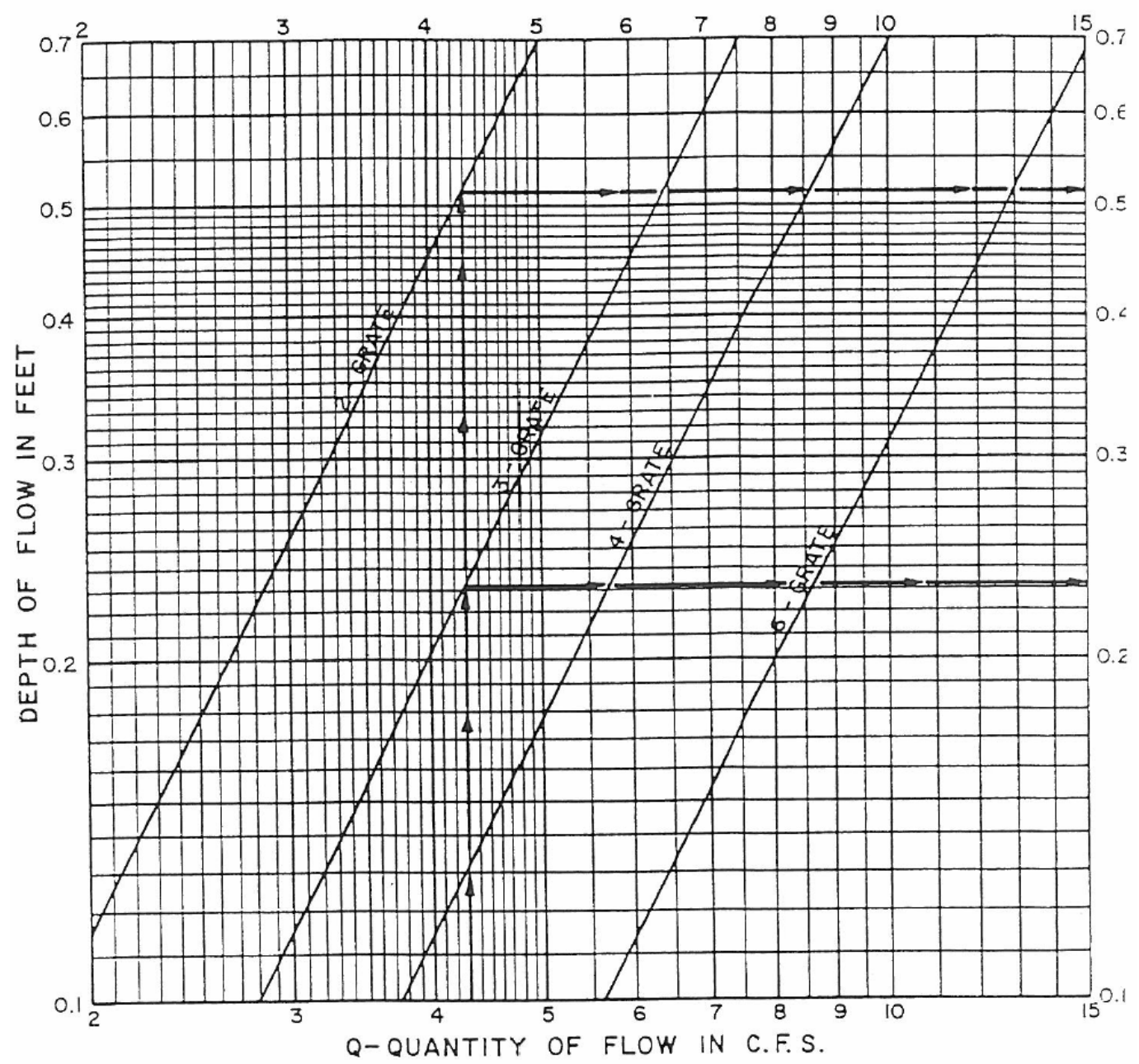
Quantity of Flow = 4.3 c.f.s.  
 Maximum Depth of Flow Desired  
 at Low Point = 0.3'

**Find:**

Inlet Required

**Solution:**

Enter Graph at 4.3 c.f.s.  
 Intersect 3 - Grate at 0.23'  
 Intersect 2 - Grate at 0.51'  
 Use 3 - Grate



GRATE INLET  
 CAPACITY CURVES  
 AT LOW POINT



FIGURE 3.20: COMBINATION INLET CAPACITY CURVES AT LOW POINT

**EXAMPLE**

**Known:**

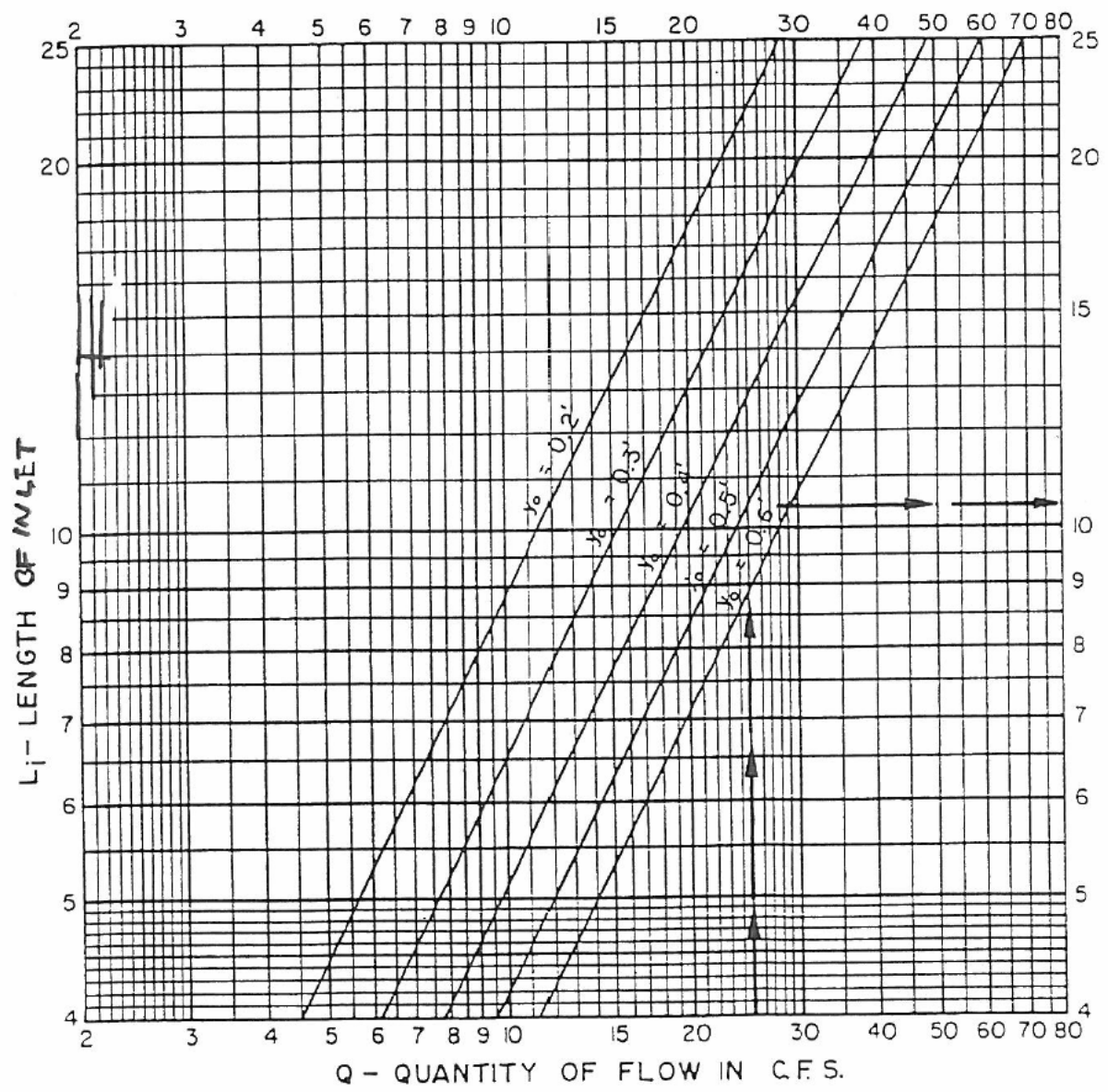
Quantity of Flow = 25.0 c.f.s.  
 Maximum Depth of Flow Desired  
 At Low Point ( $y_0$ ) = 0.5'

**Find:**

Length of Inlet Required ( $L_i$ )

**Solution:**

Enter Graph at 25.0 c.f.s.  
 Intersect  $y_0 = 0.5'$   
 Read  $L_i = 10.4'$   
 Use 12' Inlet



ROUGHNESS COEFFICIENT $n = .0175$	
STREET WIDTH	CROWN TYPE
ALL	Straight and Parabolic

COMBINATION INLET  
 CAPACITY CURVES  
 AT LOW POINT



## SUBSECTION 3.02.11 | FLOW IN STORM DRAIN CONDUITS AND THEIR APPURTENANCES

### SUBSECTION 3.02.11.01 | HYDRAULIC GRADIENT OF CONDUITS

A storm drainage conduit must have sufficient capacity to discharge a design storm with a minimum of interruption and inconvenience to the public using streets and thoroughfares. The size of the conduit is determined by accumulating runoff from contributing inlets and calculating the slope of a hydraulic gradient from *Manning's Equation*: [EQUATION 3.23](#)

#### EQUATION 3.23: MANNING'S EQUATION

$$S_f = \frac{Qn^2}{1.49AR^{2/3}}$$

#### WHERE

Q = FLOW IN CONDUIT, (CFS)

n = MANNING'S ROUGHNESS COEFFICIENT; VALUE = 0.013

A = CROSS SECTIONAL AREA OF FLOW, (FEET<sup>2</sup>)

R = HYDRAULIC RADIUS, (FEET)

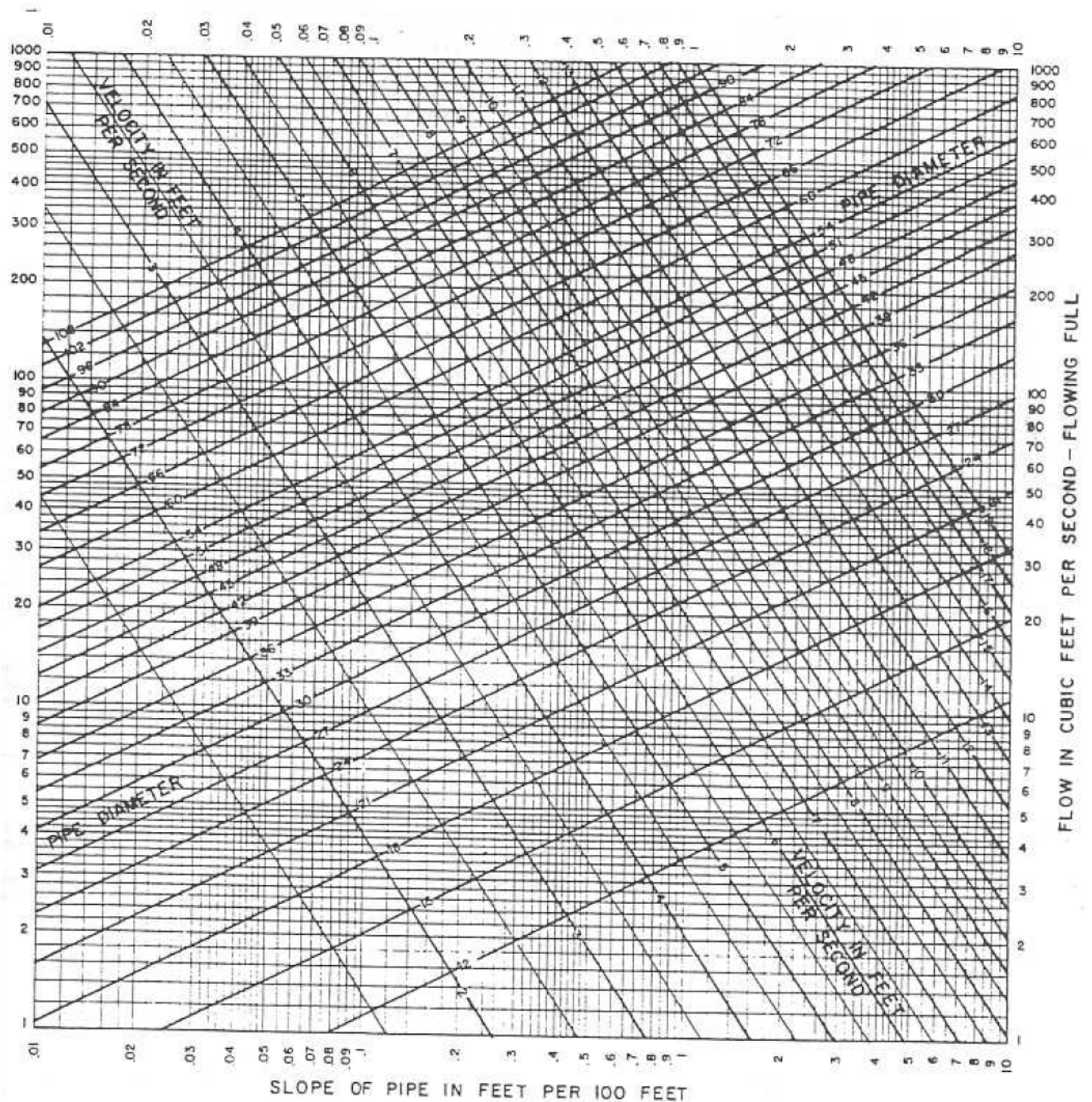
S<sub>f</sub> = HYDRAULIC FRICTION SLOPE, (FEET/FEET)

Hydraulic gradient for the selected conduit size shall be a minimum of 1.50-feet below gutter (*2.00-feet below top of curb*) for each contributing inlet to ensure that the selected conduit will carry the design flow at an elevation below the gutter profile. As the conduit size is selected and the hydraulic gradient is plotted between each inlet pickup point, a head loss due to a change in velocity and pipe size must be incorporated in the gradient profile.

At an outfall/headwall the starting hydraulic grade line (HGL) for a conduit system shall be set to the greater of the following: the conduit soffit or the 100-year water surface elevation for the receiving channel or detention pond.

Concrete pipe conduit shall be used to carry the storm water, and flow chart, [FIGURE 3.21](#), based on *Manning's Equation* may be used to determine the various hydraulic elements including the pipe size, the hydraulic gradient and the velocity. Special hydraulic calculators are also available for solution of *Manning's Equation*. All public storm lines shall be sized to carry the 100-year flow or greater. The hydraulic grade line is not allowed to be above of the public storm water pipe.

FIGURE 3.21: CAPACITY OF CIRCULAR PIPES FLOWING FULL



CAPACITY OF CIRCULAR  
PIPES FLOWING FULL

A GRAPHICAL SOLUTION  
OF  
MANNING'S EQUATION

$$V = \frac{1.486}{n} R^{2/3} S^{1/2}$$

n = 0.013



The roughness coefficient 'n' for storm sewer conduit shall be 0.013.

With the hydraulic gradient established, considerable latitude is available for establishment of the conduit flow line. The inside top of the conduit must be at or below the hydraulic gradient thus allowing the conduit to be lowered where necessary. The hydraulic gradient at every inlet should be plotted directly on the construction plan profile worksheet and adjusted as necessary.

There will be hydraulic conditions, which cause the conduits to flow partially full, and where this occurs, the hydraulic gradient should be shown at the inside crown (soffit) of the conduit. This procedure will provide a means for conservatively selecting a conduit size, which will carry the flood discharge.

All public storm sewer systems shall be reinforced concrete pipe. Storm sewer pipe, with two (2) feet or less of cover, are required to be Class IV reinforced concrete pipe. All storm pipes and laterals are required to have a plan and profile on engineering plans. All flow data ( $Q_{100}$ ,  $Q_{cap}$ , *velocity*, *hydraulic slope*) is required at every change in pipe size, slope and/or change in flow rate.

#### SUBSECTION 3.02.11.02 | MINOR HEAD LOSSES

When establishing the hydraulic grade line of a storm sewer, minor head losses at points of turbulence shall be calculated and included in the computation of the hydraulic grade line.

#### ENTRANCE LOSSES

Entrance losses to a closed storm sewer system from an open channel or lake shall be calculated using [EQUATION 3.24](#).

#### EQUATION 3.24: ENTRANCE LOSSES TO A CLOSED STORM SEWER SYSTEM FROM AN OPEN CHANNEL OR LAKE

$$H_L = K_E \frac{V_1^2}{2g}$$

WHERE:

$H_L$  = HEAD LOSS (FT)

$K_E$  = HEAD LOSS COEFFICIENT (SEE [TABLE 3.8](#)).

$V_1$  = VELOCITY IN THE DOWNSTREAM CONDUIT (FEET/SECOND)

$g$  = THE ACCELERATION OF GRAVITY (32.3 FT/S<sup>2</sup>)

**TABLE 3.8: ENTRANCE LOSS COEFFICIENTS**

TYPE OF STRUCTURE AND DESIGN OF ENTRANCE	COEFFICIENT (K <sub>e</sub> )
<b>PIPE (CONCRETE)</b>	
PROJECTING FROM FILL, SOCKET END (GROOVE-END)	0.2
PROJECTING FROM FILL, SQUARE CUT END	0.5
<b>HEADWALL OR HEADWALL AND WINGWALLS</b>	
SOCKET END OF PIPE (GROOVE-END)	0.2
SQUARE-EDGE	0.5
ROUNDED (RADIUS = 1/12D)	0.2
MITERED TO CONFORM TO FILL SLOPE	0.7
END-SECTION CONFORMING TO FILL SLOPE	0.5
BEVELED EDGES, 33.7- OR 45-DEGREE BEVELS	0.2
SIDE- OR SLOPE-TAPERED INLET	0.2
<b>PIPE, OR PIPE-ARCH, (CORRUGATED METAL)</b>	
PROJECTING FROM FILL (NO HEADWALL)	0.9
HEADWALL OR HEADWALL AND WINGWALLS SQUARE-EDGE	0.5
MITERED TO CONFORM TO FILL SLOPE, PAVED OR UNPAVED SLOPE	0.7
END-SECTION CONFORMING TO FILL SLOPE	0.5
BEVELED EDGES, 33.7-DEGREE OR 45-DEGREE BEVELS	0.2
SIDE- OR SLOPE-TAPERED INLET	0.2
<b>BOX (REINFORCED CONCRETE)</b>	
<b>HEADWALL PARALLEL TO EMBANKMENT (NO WINGWALLS)</b>	
SQUARE-EDGED ON 3 EDGES	0.5
ROUNDED ON 3 EDGES TO RADIUS OF 1/12 BARREL DIMENSION OR BEVELED EDGES ON 3 SIDES	0.2
<b>WINGWALLS AT 30- TO 75-DEGREES TO BARREL</b>	
SQUARE-EDGED AT CROWN	0.4
CROWN EDGE ROUNDED TO RADIUS OF 1/12 BARREL DIMENSION, OR BEVELED TOP EDGE	0.2
<b>WINGWALL AT 10- TO 25-DEGREES TO BARREL</b>	
SQUARE-EDGED AT CROWN	0.5
<b>WINGWALL PARALLEL (EXTENSION OF SIDES)</b>	
SQUARE-EDGED AT CROWN	0.7
SIDE- OR SLOPE-TAPERED INLET	0.2

**INLET LOSSES**

Inlet losses shall be calculated using [EQUATION 3.25](#).

**EQUATION 3.25: INLET LOSSES**

$$H_L = 1.25 \frac{V_{Lat}^2}{2g}$$

**WHERE**

H<sub>L</sub> = HEAD LOSS (FT)

V<sub>Lat</sub> = VELOCITY IN THE LATERAL (FT/S)

g = THE ACCELERATION OF GRAVITY (32.2 FT/S<sup>2</sup>)

**EXPANSION LOSSES**

For pipe size expansions, head loss shall be calculated using the following [EQUATION 3.26](#).

**EQUATION 3.26: EXPANSION LOSSES**

$$H_L = \left( 1 - \left( \frac{D_1}{D_2} \right)^2 \right) \frac{V_1^2}{2g}$$

**WHERE**

H<sub>L</sub> = HEAD LOSS (FT)

V<sub>1</sub> = UPSTREAM VELOCITY (FT/S)

D<sub>1</sub> = UPSTREAM CONDUIT DIAMETER (FT)

D<sub>2</sub> = DOWNSTREAM CONDUIT DIAMETER (FT)

g = THE ACCELERATION OF GRAVITY (32.2 FT/S<sup>2</sup>)



### MANHOLE AND BEND LOSSES

Head losses associated with manholes for pipe direction changes and bends in pipes of equal diameter shall be calculated using [EQUATION 3.27](#).

#### EQUATION 3.27: MANHOLE AND BEND LOSSES

$$H_L = K_j \frac{V_2^2}{2g}$$

#### WHERE

H<sub>L</sub> = HEAD LOSS (FT)

K<sub>e</sub> = HEAD LOSS COEFFICIENT FROM [TABLE 3.9](#).

V<sub>2</sub> = DOWNSTREAM VELOCITY (FT/S)

g = THE ACCELERATION OF GRAVITY (32.2 FT/S<sup>2</sup>)

### JUNCTION LOSSES

Head losses associated with wye connections or manholes with branch laterals entering the main line shall be calculated by using [EQUATION 3.28](#).

#### EQUATION 3.28: JUNCTION LOSSES

$$H_L = \frac{V_2^2}{2g} - K_j \frac{V_1^2}{2g}$$

#### WHERE

H<sub>L</sub> = HEAD LOSS (FT)

V<sub>1</sub> = VELOCITY IN THE UPSTREAM CONDUIT (FT/S)

V<sub>2</sub> = VELOCITY IN THE DOWNSTREAM CONDUIT (FT/S)

K<sub>e</sub> = HEAD LOSS COEFFICIENT FROM [TABLE 3.8](#).

g = THE ACCELERATION OF GRAVITY (32.2 FT/S<sup>2</sup>)



TABLE 3.9: VELOCITY HEAD LOSS COEFFICIENTS FOR CLOSED CONDUITS

MANHOLE AT CHANGE IN PIPE DIRECTION		
DESCRIPTION	ANGLE	HEAD LOSS COEFFICIENT $K_j$
<p>D1 = D2</p>	90°	0.55
	60°	0.48
	45°	0.42
	30°	0.3
	0°	0.05
BENDS IN PIPES		
DESCRIPTION	ANGLE	HEAD LOSS COEFFICIENT $K_j$
	90°	0.5
	60°	0.43
	45°	0.37
	30°	0.25
JUNCTION		
DESCRIPTION	ANGLE	HEAD LOSS COEFFICIENT $K_j$
	0°	1
	22 1/2°	0.75
	45°	0.5
	60°	0.35
	90°	0.25





### SUBSECTION 3.02.11.03 | MINIMUM GRADES

Storm drains should operate with flow velocities sufficient to prevent excessive deposits of solid materials; otherwise objectionable clogging may result. The controlling velocity with regard to sediment deposition is near the bottom of the conduit and considerably less than the mean velocity of the storm. Storm drains shall be designed to have a minimum mean velocity flowing full of 2.50-feet per second (FPS). [TABLE 3.10](#) indicates the minimum grades for concrete pipe with “Manning’s “n” = 0.013 and flowing at 2.5 FPS.

**TABLE 3.10: MINIMUM GRADES FOR STORM DRAIN PIPELINES**

PIPE DIAMETER (INCHES)	SLOPE (FOOT/FOOT)	PIPE DIAMETER (INCHES)	SLOPE (FOOT/FOOT)
18	0.0018	48	0.0005
21	0.0015	54	0.0005
24	0.0013	60	0.0004
27	0.0011	66	0.0004
30	0.0009	72	0.0003
33	0.0008	78	0.0003
36	0.0007	84	0.0003
39	0.0006	90	0.0002
42	0.0006	96	0.0002
45	0.0005	102	0.0002

### SUBSECTION 3.02.11.04 | MINIMUM GRADES

The slope of a storm sewer should also be such that excessive velocities will not damage the pipeline or drainage structures. [TABLE 3.11](#) delineates the maximum desirable velocities for storm sewer.

**TABLE 3.11: MAXIMUM VELOCITIES IN CLOSED CONDUITS**

TYPE OF CONDUIT	MAXIMUM VELOCITY
CULVERTS	15 FPS
INLET LATERALS	15 FPS
STORM SEWER PIPE	12.5 FPS

*NOTE: THE MAXIMUM VELOCITIES SHALL BE THE ACTUAL VELOCITY, FULL OR PARTIAL FLOW.*

### SUBSECTION 3.02.11.05 | DISCHARGE OF STORM DRAIN PIPE

Storm drain pipes discharging into Lake Ray Hubbard shall be set such that the top of the pipe shall be set at elevation 435.5 or otherwise approved by the City Engineer. Discharge into Lake Ray Hubbard will require approval from the City of Dallas. Pipes discharging into the lake shall run to the lake to prevent erosion of the shoreline ([FIGURE 3.22 BELOW; CITY OF DALLAS](#)).

For discharging into retention ponds or lakes other than Lake Ray Hubbard, the outfall must be at minimum the same level of the normal water surface elevation. Pipes may not be designed or discharged to retain water within the pipe longer than 48-hours.

Where storm drain pipes discharge into water courses, the invert of the pipe shall be at the same grade as the low point of the water course and angled a maximum of 60-degrees to flow downstream. Adequate grouted rock riprap or other erosion protection shall be provided, no matter the velocity. Storm sewers shall discharge into open channels at a maximum velocity allowed within the channel material type per [TABLE 3.13](#).

### SUBSECTION 3.02.11.06 | MANHOLES

Storm drain manholes shall be located at intervals not to exceed 500-feet for all public underground storm conduit systems. Manholes shall also be placed at locations where CCTV and Vac-con equipment can inspect/clean entire system without getting stuck or unable to make bends/wye connection turns. Therefore, manholes shall also be placed where there is no more than one (1) bend or wye connection between manholes or inlets. Inlet and manhole lids shall be 24-inches with locking lids.



#### SUBSECTION 3.02.11.07 | LATERAL LINES

The minimum size of public reinforced concrete storm sewer line from the inlet box to the collector lines shall be 18-inches in diameter for a discharge of less than ten (10) CFS. Where discharge exceeds ten (10) CFS and/or connects to a ten (10) foot inlet, lateral lines shall be a minimum of 21-inches in diameter.

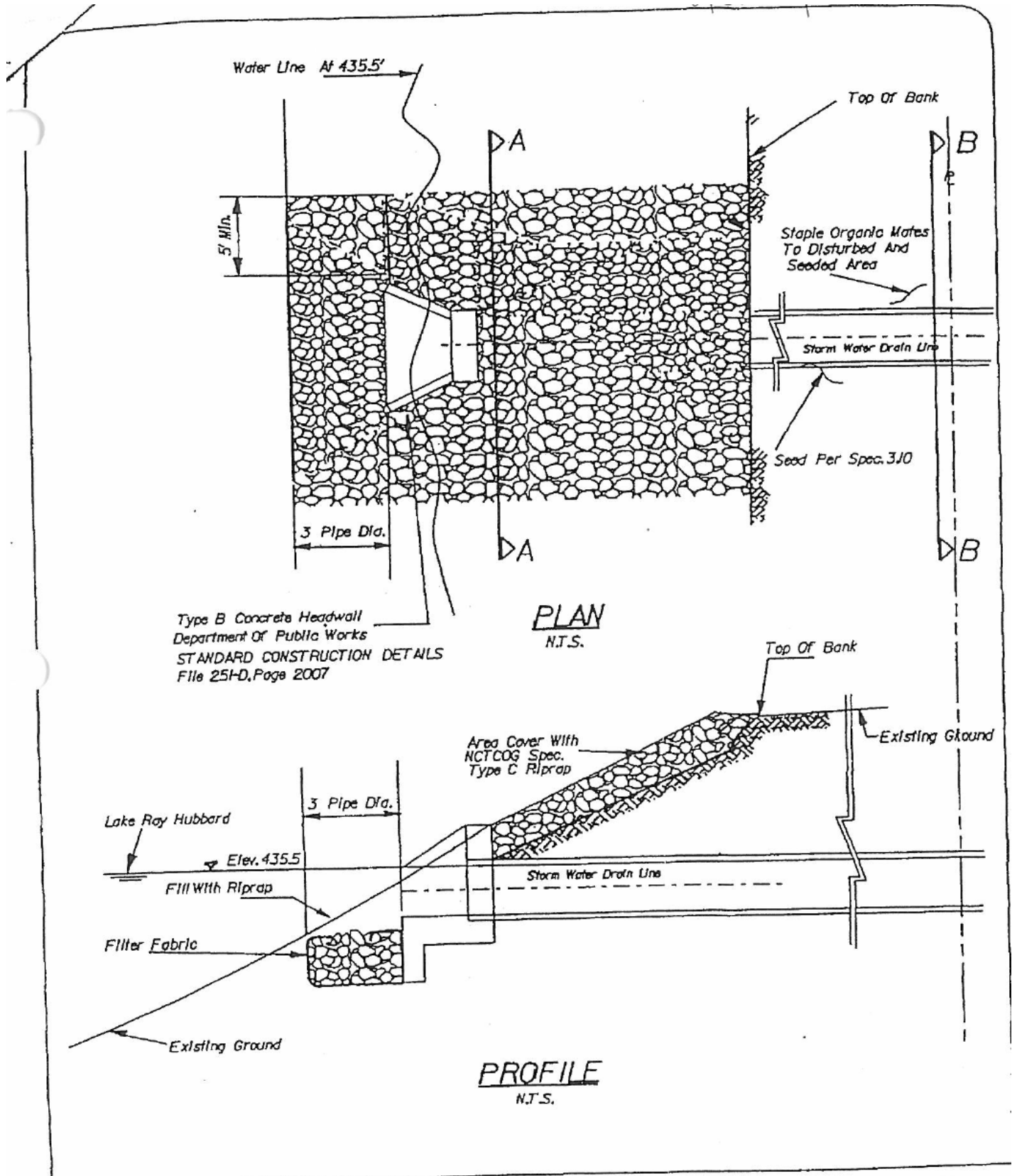
#### SUBSECTION 3.02.11.08 | UNDERDRAINS/FRENCH DRAINS

The minimum size of underdrains/French drain shall be six (6) inches in diameter. Piping shall be installed per standard detail R-6080 and connect to the nearest downstream inlet. Cleanout shall be placed at the most upstream point and at a maximum spacing of 400 feet. Horizontal location shall be adjusted as needed in order to prevent conflict with other proposed or existing utilities within corridor. 90-degree bends in small lines are prohibited. 45-degree bends or clean outs are recommended.

Any private underdrains/French drains that are discharging into City right-of-way or easements shall connect to the closest City underdrain, storm drain pipe or inlet. A clean out shall be placed at the right-of-way line to the private underdrain lateral. If a private underdrain is not in close proximity to a larger storm drain pipe or inlet system, a pop-up drain shall be installed in private property. No cutting or "punching" into City curb with pipes will be allowed.



FIGURE 3.22: LAKE RAY HUBBARD TYPICAL STORM SEWER INSTALLATION



LAKE RAY HUBBARD - TYPICAL STORM SEWER INSTALLATION



#### SUBSECTION 3.02.11.09 | FEDERAL 100-YEAR FLOOD ZONES

Where the Federal Emergency Management Administration (FEMA) has defined a flood hazard area with regard to a drainage course as shown on the effective Flood Insurance Rate Maps (FIRMs), the flood hazard zone and the floodplain, floodway, cross-section lines and water surface elevations at each cross-section, if available, shall be shown on the plat and engineering plans a minimum of every 300-feet.

#### SUBSECTION 3.02.11.10 | LOCAL 100-YEAR FLOOD ZONES

Where flood information has not been determined for streams, creeks, channels, or impoundments located within or adjacent to a proposed development, the 100-year fully developed flood elevations and flood boundaries shall be determined by the developers' engineers. The local floodplain, cross-section lines and water surface elevations at each cross-section shall be shown on the plat and engineering plans a minimum of every 300-feet. Source of the floodplain information shall be referenced.

#### SUBSECTION 3.02.11.11 | FLOODPLAIN MARKERS

The City will provide floodplain markers to be installed by the developer which shall be placed at the property corners and points of intersection of each lot adjacent to the flood plain and a maximum distance apart of 300-feet along the floodplain line.

#### SUBSECTION 3.02.11.12 | INLET MARKERS

The City will provide *No Dumping, Drains to Waterway* inlet markers to be installed on each inlet by the developer. Installation to be done at the developer's expense.

#### SUBSECTION 3.02.11.13 | DUMPSTERS

The dumpster site area shall drain through a private oil/water separator prior to connecting to the storm water system. All dumpster surface area must drain into a private slot or area drain to prevent any drainage from leaving the dumpster area. This private system shall discharge into a storm system and cannot discharge into a wastewater system or surface drain.

#### SUBSECTION 3.02.11.14 | FUELING STATIONS

If there is a fueling station on the site, the storm line serving the fueling station drainage area shall include an oil/water separator. This private system shall discharge into a storm system and cannot discharge into a wastewater system or surface drain.

#### SUBSECTION 3.02.11.15 | TESTING

All storm sewers, laterals and underdrains shall be visually inspected by video/camera at the contractor's expense prior to final acceptance by the City of Rockwall. Any sags, open joints, cracked pipes, etc. shall be repaired or removed by the contractor at the contractor's expense. Pipes shall be cleaned prior to videoing the pipe. The contractor shall furnish a DVD or flash drive of the video to the Engineering Department inspector for review. Where applicable, the storm line shall be videoed after the franchise utilities have been installed for the site.

#### SUBSECTION 3.02.12 | STORM SEWER DESIGN (CLOSED CONDUIT)

##### SUBSECTION 3.02.12.01 | GENERAL

To facilitate the design of closed conduit storm sewers, design will be based on the calculations called out in this section and the instructions for [FORM 3.3, STORM SEWER CALCULATIONS](#). [FORM 3.3](#) in its entirety shall be included in the plans and calculations shall be provided for each system including laterals.



**FORM 3.3: STORM SEWER CALCULATIONS TABLE**

SYSTEM ID	CONDUIT PROPERTIES										
	COLLECTION POINT STATION		LENGTH	# OF BARRELS	PIPE SIZE	BOX		TYPE	AREA	WETTED PERIMETER (P <sub>w</sub> )	HYDRAULIC RADIUS
	U/S	D/S				SPAN	RISE				
			FEET		INCHES	FEET	FEET		FEET <sup>2</sup>	FEET	FEET
(1)	(2)	(3)	(4)	(5)	(6)	(7)	(8)	(9)	(10)	(11)	(12)

CONDUIT PROPERTIES				INCREMENTAL DRAINAGE AREA				ACCUMULATED (C*A)	UP-STREAM (T <sub>c</sub> )	DESIGN STORM FREQUENCY
MANNING'S (n)	FLOWLINE ELEVATION		SLOPE	INLET ID	AREA	RUNOFF COEFFICIENT (C)	INCREMENTAL (C*A)			
	UP-STREAM	DOWN-STREAM						FEET/FEET	ACRES	MINUTES
(13)	(14)	(15)	(16)	(17)	(18)	(19)	(20)	(21)	(22)	(23)

INTENSITY (I)	RUNOFF (Q)	CONDUIT CAPACITY (Q <sub>c</sub> )	PARTIAL FLOW	VELOCITY (V)	TIME IN CONDUIT	FRICTION SLOPE (S <sub>f</sub> )	FRICTION HEAD-LOSS	HGL		HEADLOSS CALCULATIONS	
								U/S	D/S	$\frac{V_1^2}{2g}$	$\frac{V_2^2}{2g}$
INCH/HOUR	CFS	CFS	YES/NO	FEET/SECOND	MINUTES	FEET/FEET	FEET			FEET	FEET
(24)	(25)	(26)	(27)	(28)	(29)	(30)	(31)	(32)	(33)	(34)	(35)

HEADLOSS CALCULATIONS			DESIGN HGL	TOP OF CURB ELEVATION	HGL DEPTH BELOW (T/C)	REMARKS
JUNCTION TYPE	COEFFICIENT (K <sub>j</sub> )	HEAD-LOSS (H <sub>L</sub> )				
		FEET			FEET	
(36)	(37)	(38)	(39)	(40)	(41)	(42)



### INSTRUCTIONS FOR FORM 3.3: INLET DESIGN CALCULATIONS

COLUMN (1)	SYSTEM ID, IF PRIVATE LABEL (EX. LINE-A, LINE-B, ....; LAT-A1, LAT-A2, ....)
COLUMN (2)	STORM SEWER LINE STATION AT THE UPSTREAM END OF CONDUIT SECTION
COLUMN (3)	STORM SEWER LINE STATION AT THE DOWNSTREAM END OF CONDUIT SECTION
COLUMN (4)	LENGTH OF CONDUIT SEGMENT, EQUAL TO COLUMN (2) MINUS COLUMN (3)
COLUMN (5)	NUMBER OF BARRELS OF CONDUIT
COLUMN (6)	SIZE OF PIPE IN INCHES
COLUMN (7)	SPAN OF BOX CONDUIT
COLUMN (8)	RISE OF BOX CONDUIT
COLUMN (9)	CONDUIT TYPE (EX. RCP, RCB, PVC, HDPE, ....)
COLUMN (10)	CONDUIT AREA
COLUMN (11)	WETTED PERIMETER
COLUMN (12)	EQUAL TO COLUMN (10) DIVIDED BY COLUMN (11)
COLUMN (13)	MANNING'S ROUGHNESS COEFFICIENT
COLUMN (14)	CONDUIT FLOWLINE ELEVATION AT THE UPSTREAM END OF CONDUIT SECTION
COLUMN (15)	CONDUIT FLOWLINE ELEVATION AT THE DOWNSTREAM END OF CONDUIT SECTION
COLUMN (16)	CONDUIT SLOPE IN FEET/FEET
COLUMN (17)	THE INCREMENTAL DRAINAGE AREA ID CONTRIBUTING TO THE CONDUIT SECTION
COLUMN (18)	THE INCREMENTAL DRAINAGE AREA IN ACRES CONTRIBUTING TO THE CONDUIT SECTION
COLUMN (19)	THE INCREMENTAL DRAINAGE AREA RUNOFF COEFFICIENT CONTRIBUTING TO THE CONDUIT SECTION
COLUMN (20)	EQUAL TO COLUMN (18) MULTIPLIED BY COLUMN (19)
COLUMN (21)	EQUAL TO COLUMN (20) PLUS COLUMN (21) OF THE UPSTREAM CONDUIT SECTION
COLUMN (22)	EQUAL TO INLET TC OF MOST UPSTREAM CONDUIT SECTION, OR THE SUM OF UPSTREAM CONDUIT SECTION COLUMN (22) AND COLUMN (29)
COLUMN (23)	DESIGN STORM FREQUENCY SHALL BE 100-YR
COLUMN (24)	SHALL BE TAKEN FROM <a href="#">FIGURE 3.1</a> USING COLUMNS (22) AND (23)
COLUMN (25)	SOLUTION OF <a href="#">EQUATION 3.1</a> USING COLUMNS (21) AND (24)
COLUMN (26)	SOLUTION OF MANNING'S <a href="#">EQUATION 3.8</a> WHERE THE CONDUIT IS FLOWING FULL ( <i>DEPTH OF FLOW IS EQUAL TO HEIGHT OF CONDUIT</i> )



COLUMN (27)	YES, IF COLUMN (25) < COLUMN (26). NO, IF COLUMN (25) ≥ COLUMN (26)
COLUMN (28)	THE ACTUAL VELOCITY WITHIN THE CONDUIT
COLUMN (29)	EQUAL TO COLUMN (4) DIVIDED BY COLUMN (28) DIVIDED BY 60 SEC/MIN
COLUMN (30)	SOLUTION OF <a href="#">EQUATION 3.23</a>
COLUMN (31)	EQUAL TO COLUMN (4) MULTIPLIED BY COLUMN (30)
COLUMN (32)	UPSTREAM HYDRAULIC GRADE LINE. EQUAL TO COLUMN (33) PLUS COLUMN (31)
COLUMN (33)	THIS IS THE BEGINNING HYDRAULIC GRADIENT OF THE LINE. IT IS EQUAL TO THE DESIGN HGL COLUMN (38) FOR THE NEXT DOWNSTREAM SEGMENT, OR THE BEGINNING HGL OF THE SYSTEM.
COLUMN (34)	VELOCITY HEAD OF THE INCOMING PIPE AT THE WYE, JUNCTION, INLET OR MANHOLE.
COLUMN (35)	VELOCITY HEAD OF THE OUTGOING PIPE ( <i>THE PIPE SEGMENT BEING ANALYZED</i> ) AT THE WYE, JUNCTION, INLET OR MANHOLE.
COLUMN (36)	UPSTREAM JUNCTION TYPE ( <i>EX. INLET, 60° WYE, 30° BEND, JCT. BOX, ....</i> )
COLUMN (37)	TAKEN FROM <a href="#">TABLE 3.9</a>
COLUMN (38)	TAKEN FOR <a href="#">EQUATION 3.25</a> , <a href="#">EQUATION 3.26</a> , <a href="#">EQUATION 3.27</a> , AND <a href="#">EQUATION 3.28</a> DEPENDING ON JUNCTION TYPE
COLUMN (39)	UPSTREAM HYDRAULIC GRADE LINE DESIGN POINT OF THE CONDUIT SEGMENT. COLUMN (24) PLUS COLUMN (32)
COLUMN (40)	THE TOP OF CURB ELEVATION AT WHICH THE INLET IS LOCATED
COLUMN (41)	EQUAL TO THE COLUMN (40) MINUS COLUMN (39)
COLUMN (42)	SPECIAL DESIGN COMMENTS ARE ENTERED HERE.

### SUBSECTION 3.02.13 | STORM SEWER DESIGN (OPEN CHANNELS)

#### SUBSECTION 3.02.13.01 | GENERAL

All channels, proposed or existing, shall be designed to have a minimum bottom width of six (6) feet and based on a maximum flow and a minimum flow line slope of one (1) percent. Side slopes of channels shall not be steeper than one (1) foot rise to four (4) feet horizontal distance. Where slopes are steeper than four (4) to one (1) [*i.e.* 4:1], the slopes shall be concrete lined for slope protection. In unlined open channels, the side slopes and channel slopes shall be such that erosion is controlled and the channel is stable. Channels discharging into Lake Ray Hubbard must have City of Dallas approval and shall have inverts a minimum of two (2) feet below normal conservation pool level (*i.e.* 435.5). Channels discharging into water courses shall have the same invert level as the water course.

The instructions for [FORM 3.4. OPEN DRAINAGE CHANNEL CALCULATIONS TABLE](#), have been included in this section to facilitate the hydraulic design of an open channel.







**INSTRUCTIONS FOR FORM 3.4: OPEN DRAINAGE CHANNEL CALCULATIONS**

COLUMN (1)	DOWNSTEAM LIMIT OF THE SECTION OF CHANNEL UNDER CONSIDERATION.
COLUMN (2)	UPSTREAM LIMIT OF THE SECTION OF CHANNEL UNDER CONSIDERATION.
COLUMN (3)	TYPE OF CHANNEL AS SHOWN SHALL BE EITHER TYPE I NATURAL UNIMPROVED CHANNEL, TYPE II UNLINED WITH MAINTENANCE SECTION, (CONCRETE PILOT CHANNEL) OR TYPE III, CONCRETE LINED CHANNEL.
COLUMN (4)	FLOW IN THE SECTION OF CHANNEL UNDER CONSIDERATION.
COLUMN (5)	ROUGHNESS COEFFICIENT OF THE CHANNEL CROSS-SECTION TAKEN FROM <a href="#">TABLE 3.12</a> .
COLUMN (6)	SLOPE OF THE CHANNEL WHICH IS MOST OFTEN PARALLEL TO SLOPE OF THE HYDRAULIC GRADIENT.
COLUMN (7)	SQUARE ROOT OF COLUMN (6).
COLUMN (8)	CALCULATION IS MADE USING THE VALUES IN COLUMNS (4), (5) AND (7).
COLUMN (9)	ASSUMED WIDTH OF THE BOTTOM WIDTH OF THE CHANNEL.
COLUMN (10)	ASSUMED DEPTH OF FLOW.
COLUMN (11)	ASSUMED SLOPE OF THE SIDES OF THE CHANNEL.
COLUMN (12)	AREA OF FLOW WHICH IS CALCULATED BASED ON COLUMNS (9), (10) AND (11).
COLUMN (13)	WETTER PERIMETER CALCULATED FROM COLUMNS (9), (10) AND (11).
COLUMN (14)	VALUE IS CALCULATED FROM COLUMNS (12) AND (13).
COLUMN (15)	COLUMN (14) RAISED TO 2/3 POWER.
COLUMN (16)	PRODUCT OF COLUMN (13) TIMES COLUMN (15).
<p><b>NOTE:</b> WHEN THE VALUE OF COLUMN (16) EQUALS THE VALUE OF COLUMN (8) THE CHANNEL HAS BEEN ADEQUATELY SIZED. WHEN THE VALUE OF COLUMN (16) EXCEEDS THE VALUE OF COLUMN (8) BY MORE THAN FIVE PERCENT, THE CHANNEL WIDTH OR DEPTH SHOULD BE DECREASED AND ANOTHER TRIAL SECTION ANALYZED.</p>	
COLUMN (17)	CALCULATION IS BASED ON THE VALUES OF COLUMNS (4) AND (12)
COLUMN (18)	CALCULATION IS BASED ON COLUMN (17)
COLUMN (19)	REMARKS CONCERNING THE CHANNEL SECTION ANALYZED MAY BE ENTERED.



TABLE 3.12: ROUGHNESS COEFFICIENTS FOR OPEN CHANNELS AND MAXIMUM VELOCITY

Channel Description	Roughness Coefficient			Maximum Velocity
	Minimum	Normal	Maximum	
<u>Minor Natural Streams - Type I Channel</u>				
Moderately Well Defined Channel				
Grass and Weeds, Little Brush	0.025	0.030	0.033	8
Dense Weeds, Little Brush	0.030	0.035	0.040	8
Weeds, Light Brush on Banks	0.030	0.035	0.040	8
Weeds, Heavy Brush on Banks	0.035	0.050	0.060	8
Weeds, Dense Willows on Banks	0.040	0.060	0.080	8
Irregular Channel with Pools and Meanders				
Grass and Weeds, Little Brush	0.030	0.036	0.042	8
Dense Weeds, Little Brush	0.036	0.042	0.048	8
Weeds, Light Brush on Banks	0.036	0.042	0.048	8
Weeds, Heavy Brush on Banks	0.042	0.060	0.072	8
Weeds, Dense Willows on Banks	0.048	0.072	0.096	8
Flood Plain, Pasture				
Short Grass, No Brush	0.025	0.030	0.035	8
Tall Grass, No Brush	0.030	0.035	0.050	8
Flood Plain, Cultivated				
No Crops	0.025	0.030	0.035	8
Mature Crops	0.030	0.040	0.050	8
Flood Plain, Uncleared				
Heavy Weeds, Light Brush	0.035	0.050	0.070	8
Medium to Dense Brush	0.070	0.100	0.160	8
Trees with Flood State below Branches	0.080	0.100	0.120	8
<u>Major Natural Streams - Type I Channel</u>				
The roughness coefficient is less than that for minor streams of similar description because banks offer less effective resistance.				
Moderately Well Defined Channel	0.025	---	0.060	8
Irregular Channel	0.035	---	0.100	8
<u>Unlined Vegetated Channels - Type II Channel</u>				
Mowed Grass, Clay Soil	0.025	0.030	0.035	8
Mowed Grass, Sandy Soil	0.025	0.030	0.035	6
<u>Unlined Non-Vegetated Channels - Type II Channel</u>				
Clean Gravel Section	0.022	0.025	0.030	8
Shale	0.025	0.030	0.035	10
Smooth Rock	0.025	0.030	0.035	15
<u>Lined Channels - Type II</u>				
Smooth Finished Concrete	0.013	0.015	0.020	15
Riprap (Rubble)	0.030	0.040	0.050	12

**SUBSECTION 3.02.14 | CULVERT DESIGN**

**SUBSECTION 3.02.14.01 | GENERAL**

The design of culverts shall be sized to convey the discharge of the design flood frequency of 100-year fully-developed watershed. The hydraulic calculations shall be entered into [FORM 3.5](#), which is further described herein. If computer modeling software is used in culvert design such as *HY-8*, *HEC-RAS*, etc. all input and output parameters shall be included in the plans, or in a certified report referenced in the plans.

Where a parallel culvert is to be placed in a roadside ditch the culvert headwalls shall start at the end of the curb return or driveway radius and extend beyond the return. All driveway culverts are to be maintained, repaired, and replaced by the property owner or HOA.

Minimum Culvert Diameter shall be 18-inch and be reinforced concrete pipe.

(A) Information in the upper right of form:

- Culvert Location. This is a word description of the physical location.
- Length. The actual length of the culvert.
- Total Discharge (Q). This is the flow computed on [FORM 3.1](#).
- Design Storm Frequency. 100-year storm
- Roughness Coefficient (n). Value = 0.013.
- Maximum Discharge Velocity. Obtained from [TABLE 3.13](#).
- Tailwater. This is the design depth of water in the downstream channel and is obtained in connection with the channel design performed on [FORM 3.4](#).
- D.S. Channel Width. This is the bottom width of the downstream channel. The culvert should be sized to approximate this width whenever possible.
- Entrance Description. This is a listing of the actual condition as shown in the *Culvert Entrance Data* shown on the calculation sheet.
- Roadway Elevation. The elevation of the top of curb at the upstream end of culvert.
- U.S. Culvert F.L. The flow line of the culvert at the upstream end.
- Difference. The difference in elevations of the roadway and the upstream flow line.
- Required Freeboard. The vertical distance required for safety between the upstream design water surface and the roadway elevation or such other requirements, which may occur because of particular physical conditions.
- Allowable Headwater. This is obtained by subtracting the freeboard from the difference shown immediately above.
- D.S. Culvert F.L. The flow line elevation of the downstream end of the culvert.
- Culvert Slope (S). This is the physical slope of the structure calculated as indicated.

The instructions for [FORM 3.5](#): Culvert Design Calculations Table have been included in this section to facilitate the hydraulic design of a culvert.

**TABLE 3.13: CULVERT DISCHARGE VELOCITIES**

CULVERT DISCHARGES ON	MAXIMUM ALLOWABLE VELOCITY (FPS)
EARTH (SANDY)	6
EARTH (CLAY)	8
SODDED EARTH	8
CONCRETE	15
SHALE	10
ROCK	15

\*Note: Velocities are based on actual velocity - partial or full flow



FORM 3.5: CULVERT DESIGN CALCULATIONS TABLE

### CULVERT DESIGN CALCULATIONS

#### INLET CONTROL

CASE I  
INLET NOT SUBMERGED

CASE II  
INLET SUBMERGED

#### OUTLET CONTROL

CASE III  
OUTLET SUBMERGED

CASE IV  
OUTLET NOT SUBMERGED

#### CULVERT ENTRANCE DATA

CONCRETE BOX CULVERT

TYPE	FLARE ANGLE	ENTRANCE EDGE	K <sub>e</sub>
1A	30° to 75°	Square	0.4
1B	30° to 75°	Round	0.3
2A	15° to 30° & 75° to 90°	Square	0.5
2B	15° to 30° & 75° to 90°	Round	0.3
3A	0° (Extension of Sides)	Square	0.7
3B	0° (Extension of Sides)	Round	0.5

CONCRETE PIPE

TYPE	ENTRANCE DESCRIPTION	K <sub>e</sub>
4	Spigot End With Headwall	0.5
5	Bell End With Headwall	0.2
6A	Bell End Projecting With No Headwall	0.3
6B	Spigot End Projecting With No Headwall	0.6

CULVERT LOCATION: \_\_\_\_\_ LENGTH, L \_\_\_\_\_

TOTAL DISCHARGE, Q \_\_\_\_\_ DESIGN STORM FREQ. \_\_\_\_\_

ROUGHNESS COEFF., n \_\_\_\_\_ MAX. VEL. \_\_\_\_\_

TAILWATER \_\_\_\_\_ D.S. CHANNEL WIDTH \_\_\_\_\_

ENTRANCE DESCRIPTION \_\_\_\_\_

RDWY. ELEV. \_\_\_\_\_ U.S. CULV. F.L. \_\_\_\_\_

U.S. CULV. F.L. \_\_\_\_\_ D.S. CULV. F.L. \_\_\_\_\_

DIFFERENCE \_\_\_\_\_ DIFFERENCE \_\_\_\_\_

REDD. FREEBOARD \_\_\_\_\_ FT. CULV. SLOPE, S<sub>o</sub> \_\_\_\_\_ DIFF. FT. \_\_\_\_\_

ALLOW. HEADWATER \_\_\_\_\_ FT. S<sub>o</sub> \_\_\_\_\_

#### HEADWATER CALCULATION

OUTLET CONTROL (See Figures 27, 28, 29, & 30)

Trial Area of Opening $T_A = \frac{W \times D}{4}$ (sq. ft.)	DEPTH RANGE D.R.		No. of Openings	Width of Box "B" (feet)	Box Depth or Pipe Dia. "D" (feet)	Total Culvert Area "A <sub>c</sub> " (sq. ft.)	"O" Each Opening (c.f.t.)	INLET CONTROL (See Figure 25B26)		OUTLET CONTROL (See Figures 27, 28, 29, & 30)						The Greater Head Controlling														
	Channel Width "W" (feet)	T <sub>Ac</sub> / W (feet)						AHW (feet)	Depth "D" (feet)	Entrance Type	Case No.	$\frac{D}{B}$ (c.f.t.)	$\frac{HW}{D}$ (figure 25B26)	Entrance Coeff. K <sub>e</sub>	HW (feet)		HW + H + TW (figure 27B28)	L x S <sub>o</sub> (feet)	"HW" (feet)	HW + H + hg - L x S <sub>o</sub> (feet)	HW x $\frac{dc}{2}$ or hg - TW (use larger) (figure 27B30)	L x S <sub>o</sub> (feet)	"HW" (feet)	Water (Inlet or Outlet) (feet)	SELECTED CONDUIT SIZE					
1	2	3	4	5	6	7	8	9	10	11	12	13	14	15	16	17	18	19	20	21	22	23	24	25	26	27	28	29		



## INSTRUCTIONS FOR FORM 3.5: CULVERT DESIGN CALCULATIONS

**NOTE:** COLUMNS 1 THROUGH 10 DEAL WITH SELECTION OF TRIAL CULVERT SIZE AND ARE EXPLAINED AS FOLLOWS:

COLUMN (1)	TOTAL DESIGN DISCHARGE, Q, PASSING THROUGH THE CULVERT DIVIDED BY THE ALLOWABLE MAXIMUM VELOCITY GIVES TRIAL TOTAL AREA OF CULVERT OPENING.
COLUMN (2)	CULVERT WIDTH SHOULD BE REASONABLY CLOSE TO THE CHANNEL BOTTOM WIDTH, W, DOWNSTREAM OF THE CULVERT.
COLUMN (3)	LOWER RANGE FOR CHOOSING CULVERT DEPTH IS TRIAL AREA OF CULVERT OPENING, COLUMN (1) DIVIDED BY CHANNEL WIDTH, COLUMN (2).
COLUMN (4)	ALLOWABLE HEADWATER OBTAINED FROM UPPER RIGHT OF SHEET.
COLUMN (5)	TRIAL DEPTH, D, OF CULVERT CORRESPONDING TO AVAILABLE STANDARD SIZED AND BETWEEN THE NUMERICAL VALUES OF COLUMNS (3) AND (4).

**NOTE:** COLUMNS (6), (7) AND (8) ARE SOLVED SIMULTANEOUSLY BASED ON PROVIDING A TOTAL AREA EQUIVALENT TO THE TRIAL AREA OF OPENING IN COLUMN (1).

COLUMN (6)	NUMBER OF CULVERT OPENINGS.
COLUMN (7)	INSIDE WIDTH OF ONE OPENING.
COLUMN (8)	INSIDE DEPTH OF ONE OPENING IF CULVERT IS BOX STRUCTURE OR DIAMETER IF CULVERT IS PIPE.
COLUMN (9)	COLUMN 6 MULTIPLIED BY COLUMN (7) AND COLUMN (8).
COLUMN (10)	TOTAL DISCHARGE DIVIDED BY NUMBER OF OPENINGS SHOWN IN COLUMN (6).

**NOTE:** COLUMNS (11) THROUGH (15) (INLET CONTROL) AND (16) THROUGH (27) (OUTLET CONTROL) DEAL WITH HEADWATER CALCULATIONS WHICH VERIFY HYDRAULICS OF TRIAL CULVERT SELECTED AND ARE EXPLAINED AS FOLLOWS.

COLUMN (11)	OBTAINED FROM UPPER RIGHT OF SHEET.
COLUMN (12)	WHEN THE ALLOWABLE HEADWATER IS EQUAL TO OR LESS THAN THE VALUE IN COLUMN (8), ENTER CASE I. WHEN THE ALLOWABLE HEADWATER IS MORE THAN THE VALUE IN COLUMN (8), ENTER CASE II.
COLUMN (13)	COLUMN 10 DIVIDED BY COLUMN (7).
COLUMN (14)	OBTAINED FROM <a href="#">FIGURE 3.23</a> FOR BOX CULVERTS OR <a href="#">FIGURE 3.24</a> FOR PIPE CULVERTS.
COLUMN (15)	COLUMN (14) MULTIPLIED BY COLUMN (8).
COLUMN (16)	OBTAINED FROM UPPER PART OF SHEET.
COLUMN (17)	OBTAINED FROM <a href="#">FIGURE 3.25</a> FOR BOX CULVERTS AND <a href="#">FIGURE 3.26</a> FOR PIPE CULVERTS.
COLUMN (18)	TAILWATER DEPTH FROM UPPER RIGHT OF SHEET.
COLUMN (19)	CULVERT SLOPE, S, MULTIPLIED BY CULVERT LENGTH, BOTH OBTAINED FROM UPPER RIGHT OF SHEET.
COLUMN (20)	SUM OF COLUMNS (17) AND (18), MINUS COLUMN (19).
COLUMN (21)	OBTAINED FROM <a href="#">FIGURE 3.25</a> FOR BOX CULVERTS AND <a href="#">FIGURE 3.26</a> FOR PIPE CULVERTS.
COLUMN (22)	CRITICAL DEPTH OBTAINED FROM <a href="#">FIGURE 3.27</a> FOR BOX CULVERTS AND <a href="#">FIGURE 3.28</a> FOR PIPE CULVERTS.
COLUMN (23)	SUM OF COLUMNS (22) AND (8) DIVIDED BY (2).



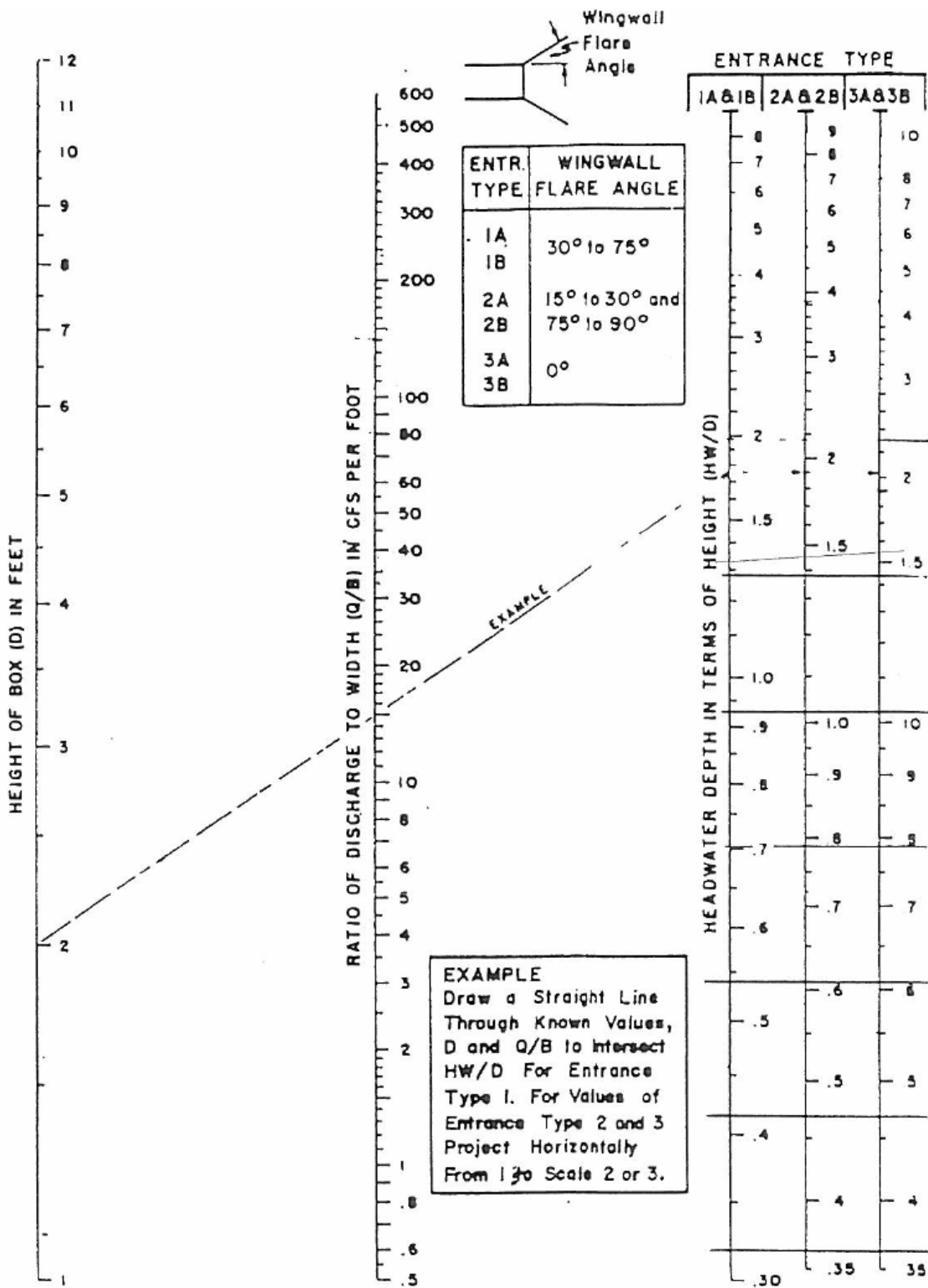
---

COLUMN (24)	TAILWATER DEPTH FROM UPPER RIGHT OF SHEET.
COLUMN (25)	ENTER THE LARGER OF THE TWO VALUES SHOWN IN COLUMN (23) OR COLUMN (24).
COLUMN (26)	PREVIOUSLY CALCULATED IN COLUMN (19) AND MAY BE TRANSPOSED.
COLUMN (27)	THE SUM OF COLUMNS (21) AND (25) MINUS COLUMN (26).
COLUMN (28)	ENTER THE LARGER OF THE VALUES FROM EITHER COLUMN (15), COLUMN (20) OR COLUMN (27). THIS DETERMINES THE CONTROLLING HYDRAULIC CONDITIONS OF THE PARTICULAR SIZE CULVERT INVESTIGATED.
COLUMN (29)	WHEN THE ENGINEER IS SATISFIED WITH THE HYDRAULIC INVESTIGATIONS OF VARIOUS CULVERTS AND HAS DETERMINED WHICH WOULD BE THE MOST ECONOMICAL SELECTION; THE DESCRIPTION SHOULD BE ENTERED.

---



FIGURE 3.23: HEADWATER DEPTH FOR CONCRETE BOX CULVERT WITH INLET CONTROL

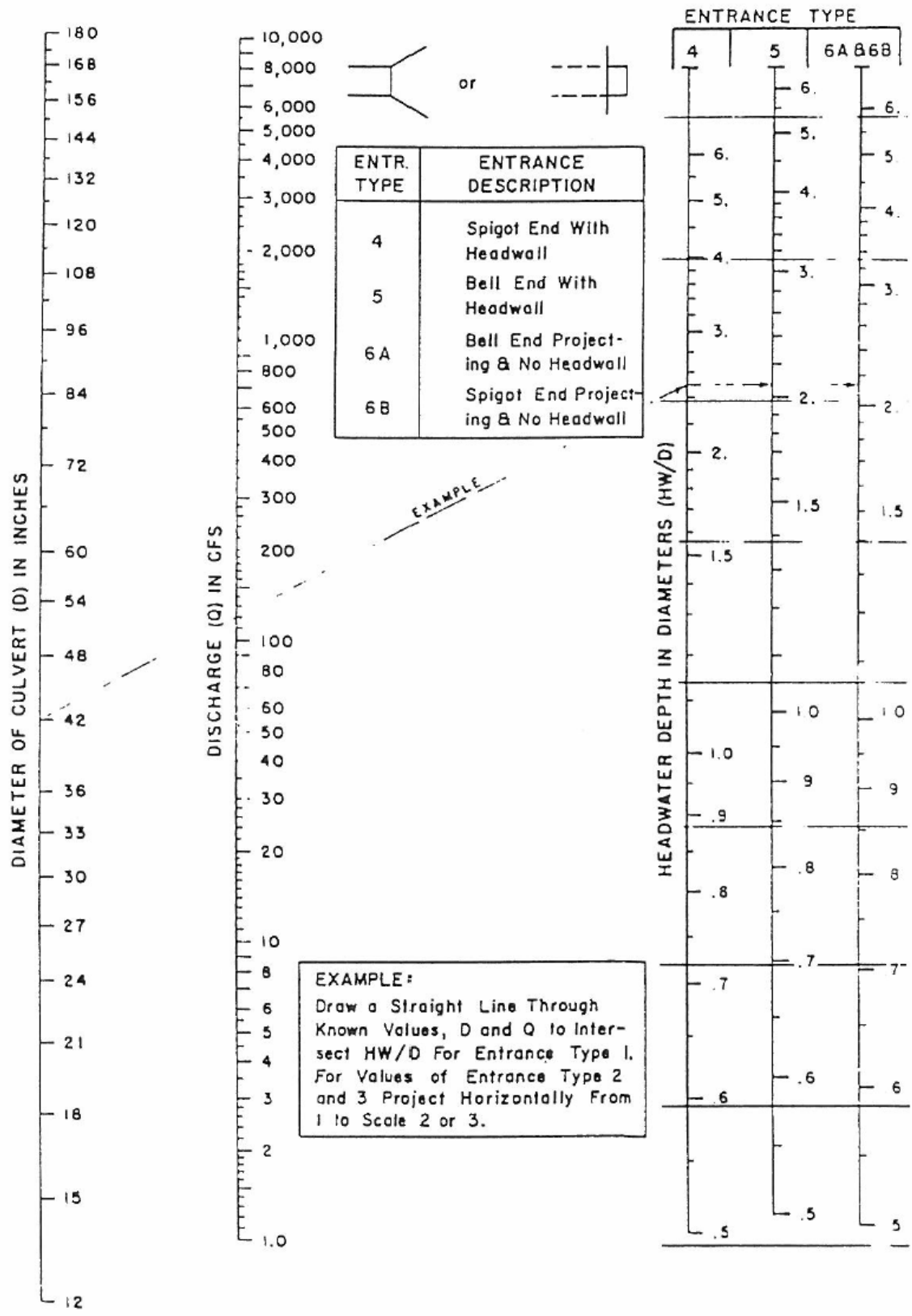


BUREAU OF PUBLIC ROADS JAN 1963

HEADWATER DEPTH FOR CONCRETE BOX CULVERT WITH INLET CONTROL



FIGURE 3.24: HEADWATER DEPTH FOR CONCRETE PIPE CULVERT WITH INLET CONTROL



**EXAMPLE:**  
 Draw a Straight Line Through Known Values, D and Q to Intersect HW/D For Entrance Type 1. For Values of Entrance Type 2 and 3 Project Horizontally From 1 to Scale 2 or 3.

HEADWATER DEPTH FOR CONCRETE PIPE CULVERTS WITH INLET CONTROL



FIGURE 3.25: HEAD FOR CONCRETE BOX CULVERT FLOWING FULL

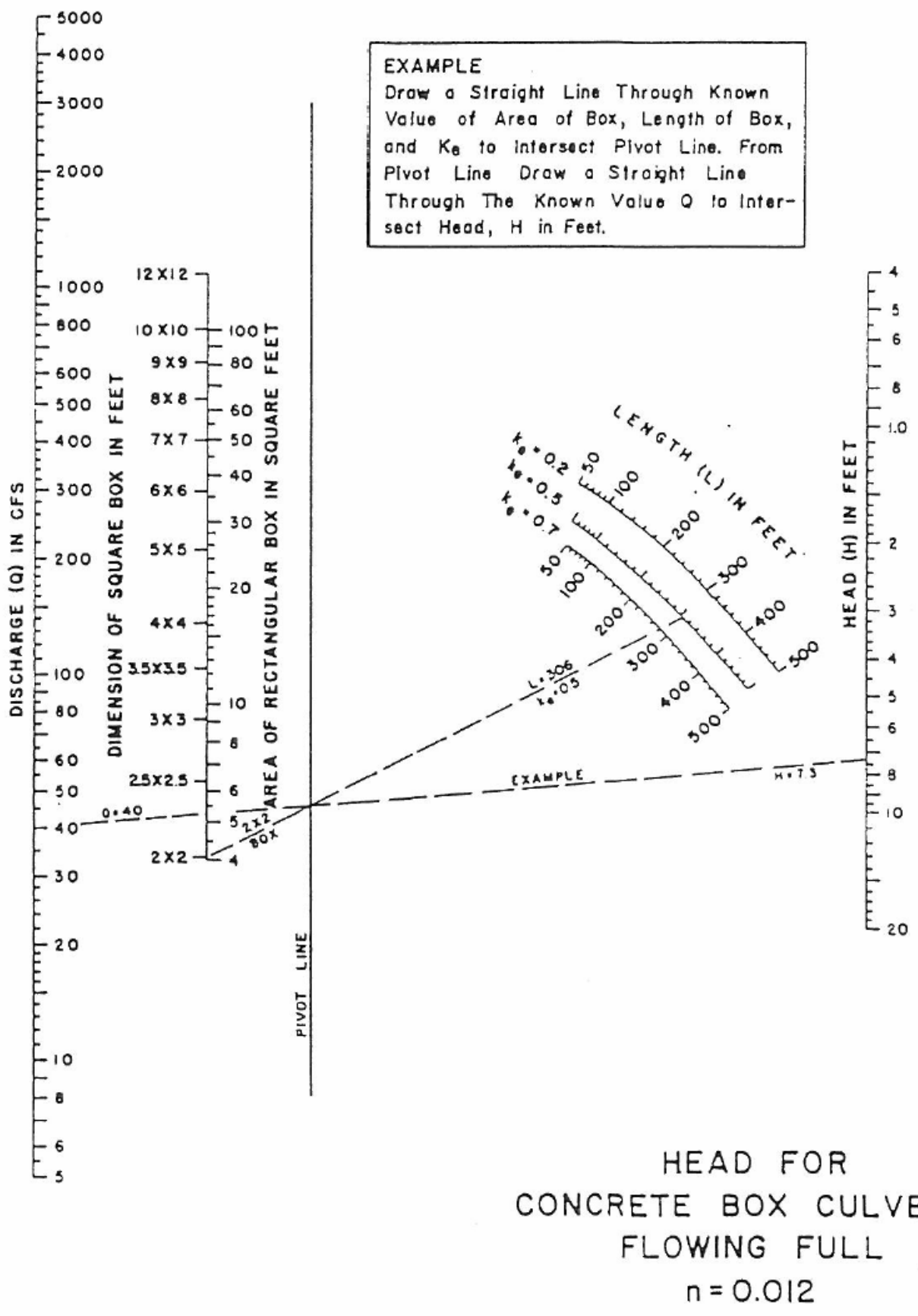
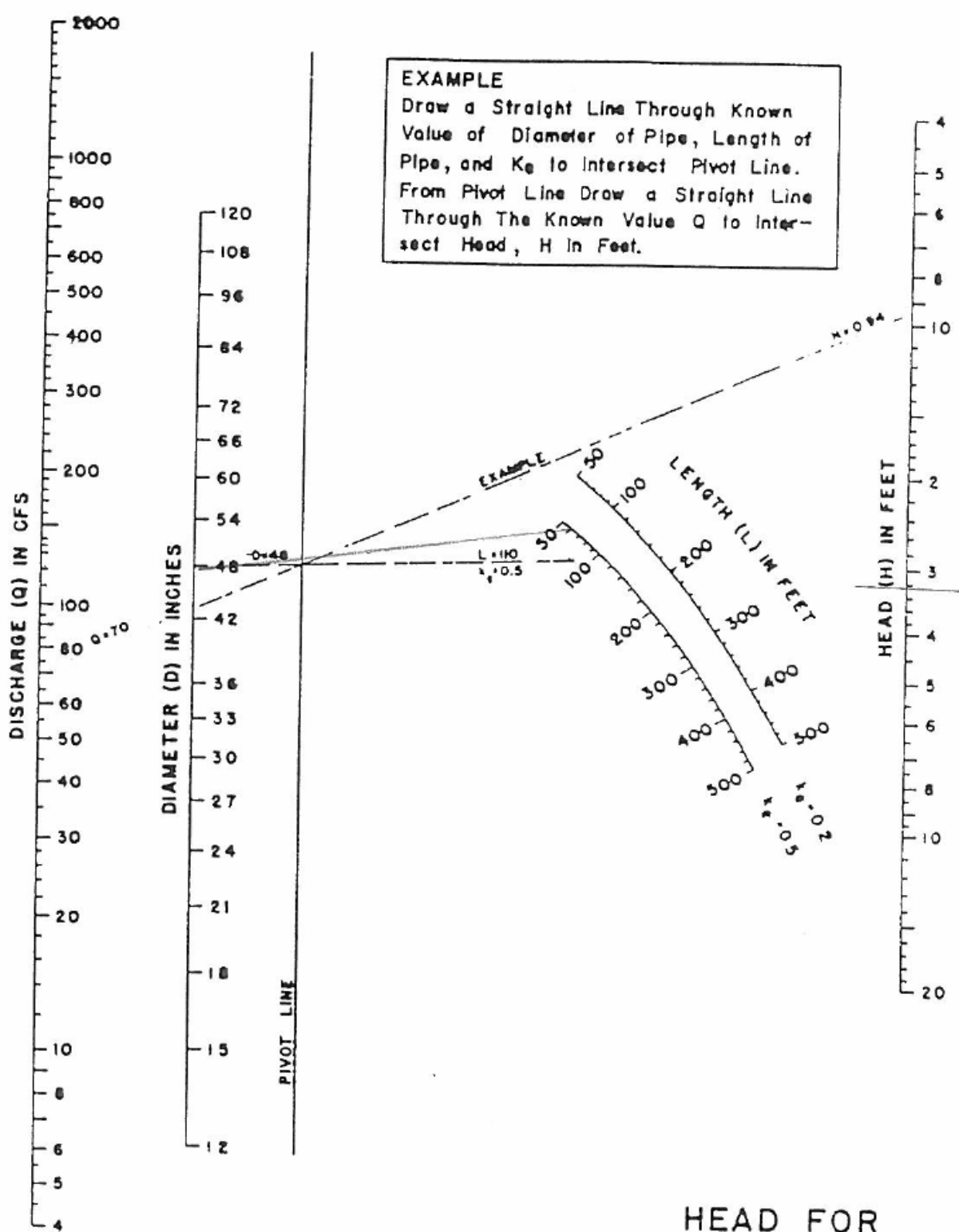


FIGURE 3.26: HEAD FOR CONCRETE PIPE CULVERTS FLOWING FULL



**EXAMPLE**  
 Draw a Straight Line Through Known Value of Diameter of Pipe, Length of Pipe, and  $K_e$  to Intersect Pivot Line. From Pivot Line Draw a Straight Line Through The Known Value  $Q$  to Intersect Head,  $H$  In Feet.

HEAD FOR  
 CONCRETE PIPE CULVERTS  
 FLOWING FULL  
 $n = 0.012$

BUREAU OF PUBLIC ROADS JAN 1963

FIGURE 3.27: CRITICAL DEPTH OF FLOW FOR RECTANGULAR CONDUITS

**EXAMPLE**

**Known:**

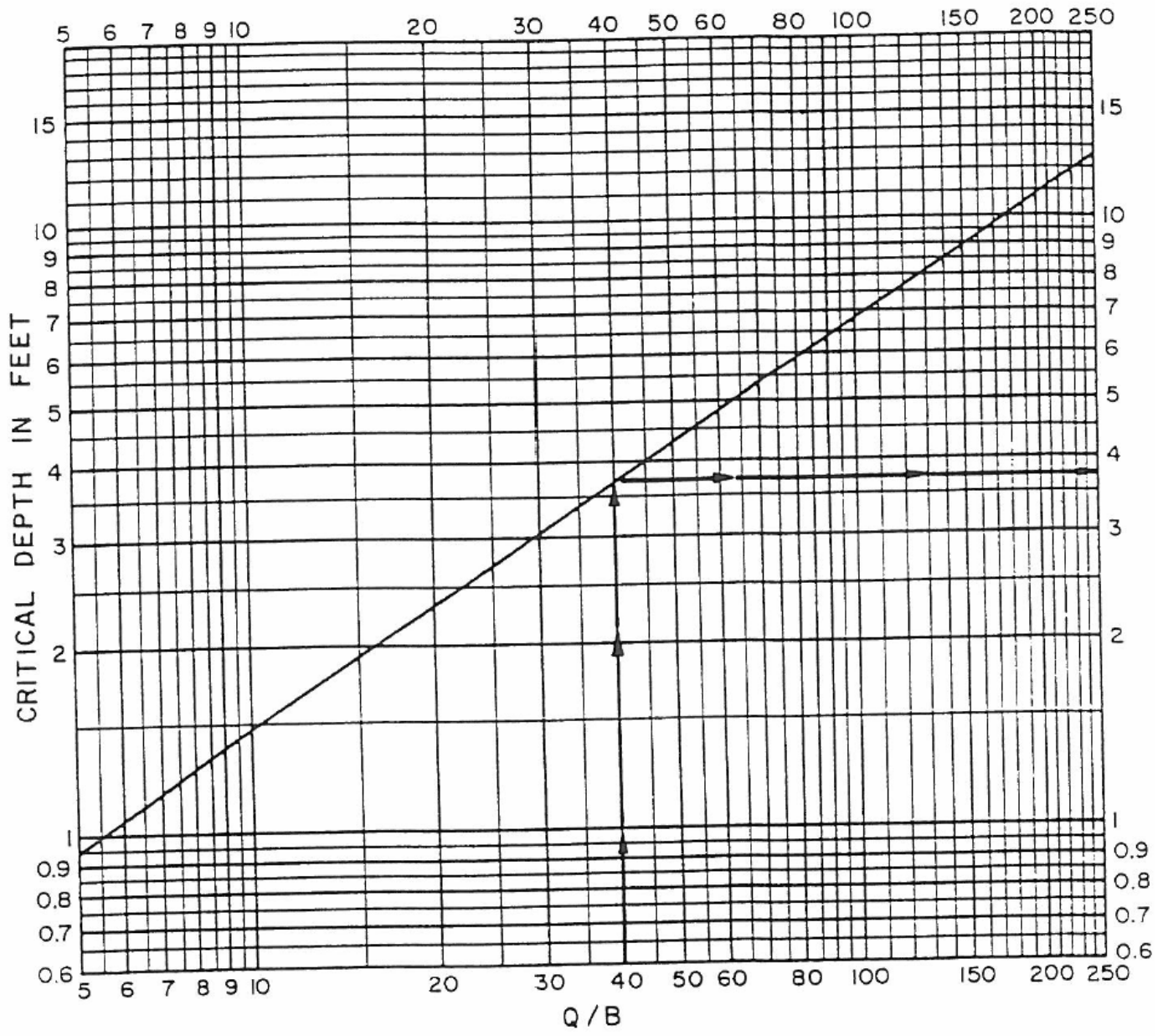
- Discharge = 200 c.f.s.
- Width of Conduit = 5'
- $Q/B = 40$

**Solution:**

- Enter Graph at  $Q/B = 40$
- Intersect Critical Depth at 3.7

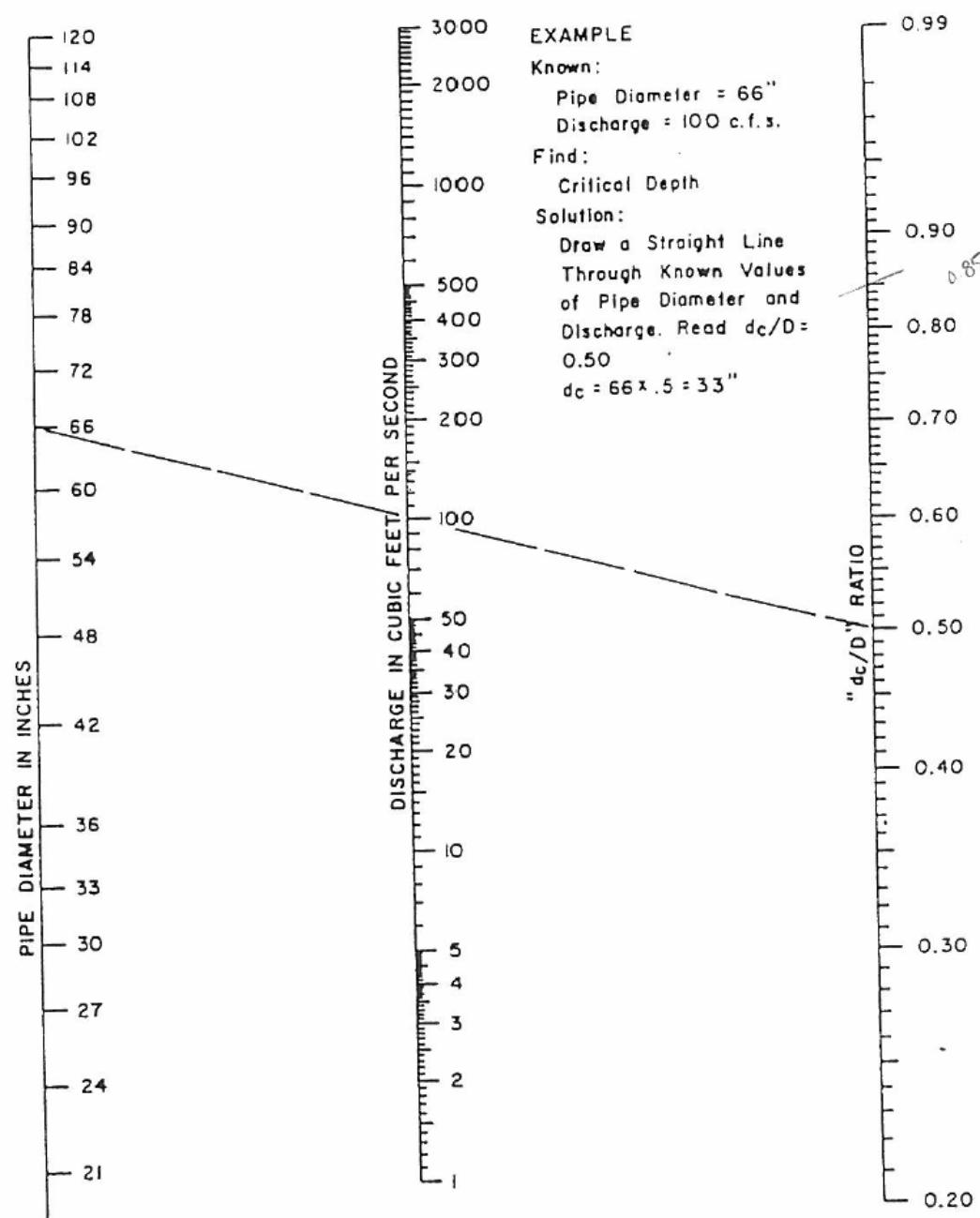
**Find:**

Critical Depth



CRITICAL DEPTH OF FLOW FOR RECTANGULAR CONDUITS

FIGURE 3.28: CRITICAL DEPTH OF FLOW FOR CIRCULAR CONDUITS



**EXAMPLE**  
 Known:  
 Pipe Diameter = 66"  
 Discharge = 100 c.f.s.  
 Find:  
 Critical Depth  
 Solution:  
 Draw a Straight Line  
 Through Known Values  
 of Pipe Diameter and  
 Discharge. Read  $d_c/D =$   
 0.50  
 $d_c = 66 \times .5 = 33''$

$d_c$  = Critical Depth of Flow in Inches  
 $D$  = Pipe Diameter in Inches

CRITICAL DEPTH OF FLOW  
 FOR  
 CIRCULAR CONDUITS



### SUBSECTION 3.02.15 | BRIDGE DESIGN

- (A) A scour analysis shall be performed and submitted in or with the design plans.
- (B) For all bridges a flood study report shall be prepared and provided to the City Engineer, documenting the methodology, assumptions, derivation of all data used, and results of the study.
- (C) The 100-year projected fully developed water surface elevation shall not be increased upstream or downstream of the bridge.
- (D) If utilities are connected to a bridge, utility shall be connected to the downstream side of bridge support members.

### SUBSECTION 3.02.16 | EROSION HAZARD SETBACK

#### SUBSECTION 3.02.16.01 | DEFINITION AND PURPOSE

Erosion hazard setbacks shall be determined for every stream and creek (*flowing or not*) in which natural channels are to be preserved. The purpose of this erosion hazard setback is to reduce the potential for any damage to a private lot, building, utilities or street right-of-way caused by the natural erosion of the creek bank and to minimize the expenditure of public funds for stream bank stabilization projects. The erosion hazard setback shall be included within the drainage easement and in its own lot and block. The erosion hazard setback shall be maintained by the property owner. Erosion hazard setback and easement may not be located on a single-family residential lot in a new subdivision.

#### SUBSECTION 3.02.16.02 | DEFINITION AND PURPOSE

The erosion hazard setback shall be determined by the following steps:

- Locate the toe of the natural stream bank. The toe may be located outside of the low flow channel.
- Project at a 4(H):1(V) line sloping away from the center of the creek/stream until it intersects natural ground or the new proposed elevation, whichever results in the greater setback.
- From this intersecting point continue an additional 15-foot horizontally away from bank. This shall set the limit of the erosion hazard setback.
- In certain scenarios, the calculated erosion hazard setback is within the 100-year fully developed floodplain. In these scenarios, the 100-year fully developed floodplain access area shall govern for setting the drainage/floodplain easement.
- The typical erosion hazard setback established by steps above is shown in [FIGURE 3.29](#).

Proof of determination of the above shall be included in the Engineering Plan set. It shall include the following:

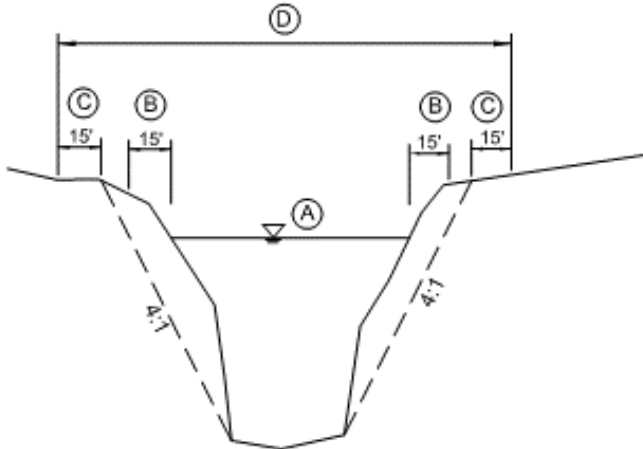
- Locating and labeling of the toe of the natural stream bank. If trapezoidal in nature both toes shall be identified.
- Existing one-foot topographic contours of the entire site.
- Projected hypothetical one-foot contours representing the 4(H):1(V) line sloping away from the center of the creek/stream until it intersects natural ground or the new proposed elevation
- Show and label hypothetical projected intersecting point/top of 4:1 slope line.
- Show and label Erosion Hazard Setback (*15-foot offset away from bank of intersecting point/top of 4:1 slope line*)
- Show and label 100-year fully developed floodplain.
- Show and label 15-foot offset from 100-year fully developed floodplain to establish the floodplain access area.
- Show and label the required *Drainage/Floodplain Easement*. The easement will be the greater of the 15-foot erosion hazard setback and 15-foot floodplain access area. Easement is a minimum 15-feet on both sides of the floodplain or erosion hazard setback. Wider easement may be required by City Engineer.



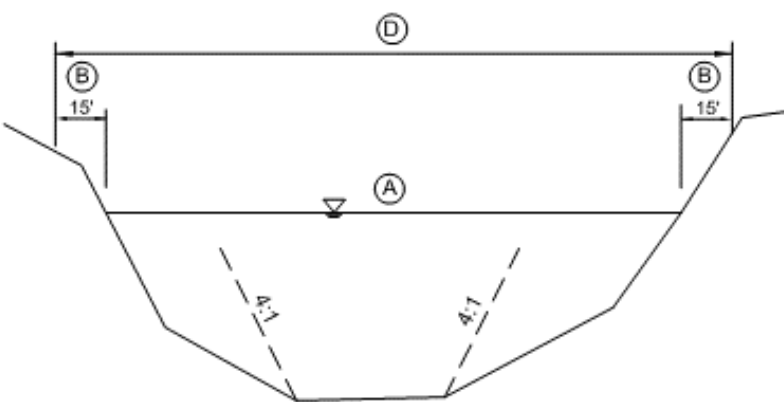
FIGURE 3.29: EROSION HAZARD SETBACKS AND DRAINAGE EASEMENTS

**NATURAL CREEKS/CHANNELS: SETBACKS AND EASEMENTS**

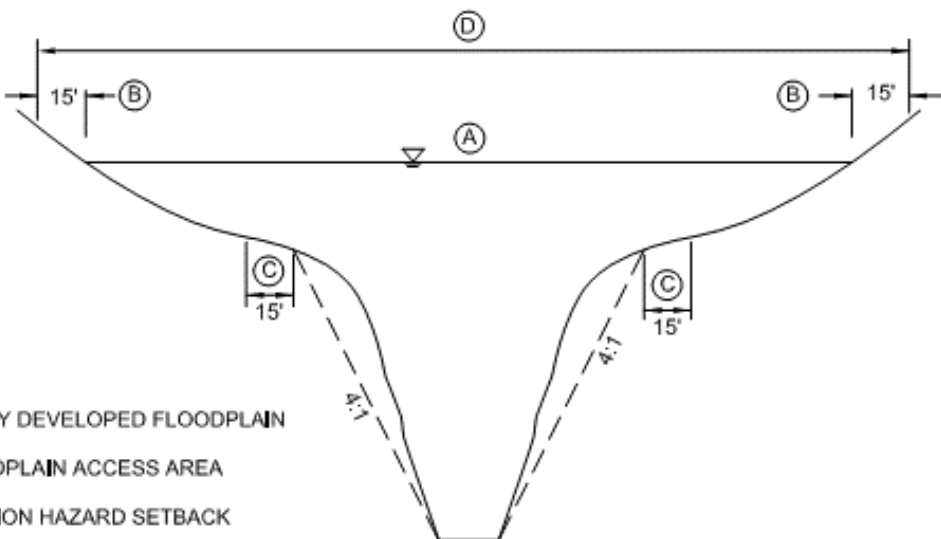
**SCENARIO 1 (Floodplain within Erosion Hazard Setback)**



**SCENARIO 2 (Erosion Hazard Setback within Floodplain)**



**SCENARIO 3 (Erosion Hazard Setback within Floodplain)**



**NOTES:**

- (A) 100 YEAR FULLY DEVELOPED FLOODPLAIN
- (B) 15 FOOT FLOODPLAIN ACCESS AREA
- (C) 15 FOOT EROSION HAZARD SETBACK
- (D) EXTENTS OF DRAINAGE/FLOODPLAIN EASEMENT



### SUBSECTION 3.02.16.03 | NON-PERMITTED STRUCTURES

The following are non-permitted structures within the drainage/floodplain/erosion hazard setback easement: building, wall, parking lot, driveway, fences, decks, swimming pools, signage, monumentation, detention structures/ponds or other structures. Water and wastewater lines shall be placed beneath the projected 4:1 slope line. The pipe shall be concrete encased when there is less than four (4) foot of cover from the 4:1 slope line.

### SUBSECTION 3.02.16.04 | MODIFICATIONS

Any modifications to the erosion hazard setback will require the following items and approval by the City Engineer:

- A geotechnical and stream geomorphological stability analysis signed and sealed by a licensed *Professional Geotechnical Engineer* within the State of Texas.
- Structural plans, calculations and report of the permanent stream bank stabilization measures signed and sealed by a licensed *Professional Structural Engineer* within the State of Texas.
- Grading permit.
- Adequate access to maintain the stream bank stabilization measures indefinitely.



## SECTION 3.03 | MINIMUM FREE BOARD REQUIREMENTS

To help prevent flood damages and protect public safety, all design elevation requirements related to water surface elevations and flood elevations shall be based, at a minimum, on the 100-year flood, fully-developed watershed conditions. The difference between a minimum design elevation and the 100-year flood elevation is commonly referred to as minimum freeboard. [TABLE 3.14](#) provides a summary of absolute minimum freeboard requirements for design and construction in the City of Rockwall. However, prudent engineering in setting design elevations should be incorporated into any design. In some situations, a greater freeboard than those listed in [TABLE 3.14](#) may be required by the City, at the discretion of the City Engineer, or as required by State and Federal regulations and guideline, depending of flood hazard potential in relation to property damages and public safety. The City's minimum freeboard requirements are not intended to take precedence over State and Federal regulations (*except when the City's requirements exceed those set by State and Federal regulations*). The minimum elevations of all flood protection levees and all dams must meet requirements of all State and Federal regulations and guidelines. If the minimum floor elevation based on floodplain is less than that based on roadway gutter elevation, the higher elevation of the frontage portion of the roadway shall be the minimum elevation.

**TABLE 3.14: MINIMUM FREE BOARD REQUIREMENTS**

DESCRIPTION	MINIMUM FREEBOARD ABOVE 100-YEAR FLOOD ELEVATION (FT) <sup>1</sup>
<b>MINIMUM FLOOR ELEVATIONS (INCLUDING BASEMENTS AND SUNKEN FLOOR AREAS):</b>	
RESIDENTIAL	2.0
NON-RESIDENTIAL (UNLESS FLOOD PROOFED; SEE FLOOD DAMAGE PREVENTION ORDINANCE)	2.0
BUILDING PAD ELEVATIONS FOR STRUCTURES (AT LOWEST ADJACENT STRUCTURE GRADE)	1.0
<b>DAMS (FREEBOARD ABOVE EFFECTIVE CREST ELEVATION OF DAM, AFTER ALLOWING FOR SETTLEMENT AND CONSOLIDATION OF EMBANKMENT):</b>	
LESS THAN OR EQUAL TO 5-FT MAXIMUM HEIGHT	1.0
MORE THAN 5-FT MAXIMUM HEIGHT (MUST MEET STATE AND FEDERAL REQUIREMENTS)	2.0
DAMS WITH ENTIRE EMBANKMENT HAVING OVERFLOW PROTECTION (SUCH AS CONCRETE)	1.0
<b>DETENTION AND RETENTION PONDS (FREEBOARD ALONG ALL SHORELINE AREAS AROUND THE POND):</b>	
PER DAM HEIGHT:	
WITH DAMS LESS THAN OR EQUAL TO 5-FT MAXIMUM HEIGHT	1.0
WITH DAMS MORE THAN 5-FEET MAXIMUM HEIGHT	2.0
INCISED PONDS (NO DAM)	1.0
PER AREA DRAINING TO POND:	
1 ACRE OR LESS DRAINAGE AREA	0.0
5 ACRES TO 1 ACRE DRAINAGE AREA	1.0
GREATER THAN 5 ACRES	2.0
<b>FLOOD PROTECTION LEVEES, DIKES, OR WALLS (CITY ENGINEER APPROVAL REQUIRED):</b>	
SIGNIFICANT OR HIGH HAZARD FLOOD DAMAGE OR PUBLIC SAFETY POTENTIAL	3.0
LOW HAZARD FLOOD DAMAGE POTENTIAL OR PUBLIC SAFETY POTENTIAL	2.0
PUBLIC ROADWAYS, ALLEYS, PARKING LOTS, COMMERCIAL DRIVEWAYS AND RESIDENTIAL DRIVEWAYS (AS MEASURED FROM EDGE OF PAVEMENT/TOP OF CURB)	1.0
CHANNELS	1.0
BRIDGES (AS MEASURED FROM LOWEST POINT OF LOW CHORD)	1.0
CULVERTS (AS MEASURED FROM EDGE OF PAVEMENT/TOP OF CURB)	1.0
SANITARY SEWER AND WATER MANHOLE COVERS	2.0

### NOTES:

<sup>1</sup>: THE 100-YEAR FLOOD ELEVATIONS AS DETERMINED BASED ON DISCHARGES RESULTING FROM A FULLY-DEVELOPED WATERSHED. GREATER FREEBOARD MAY BE REQUIRED, AT DISCRETION OF CITY ENGINEER (DEPENDING ON FLOOD HAZARD POTENTIAL) OR BY STATE AND FEDERAL REGULATIONS.

## SECTION 3.04 | DETENTION

### SUBSECTION 3.04.01 | INTENT

It is the City's intent to utilize detention (*or detention/retention*) of storm water runoff as a solution towards control of potential hazards created by storm water runoff including: [1] a reduction in the impact on downstream storm water drainage facilities, [2] prevention of erosive conditions in water drainage ways, [3] protection against downstream and adjacent property damage, and [4] preservation of existing floodplains along major creeks. Detention basins may also improve water quality by allowing some sediment to settle out.

### SUBSECTION 3.04.02 | WHERE IS DETENTION REQUIRED?

(A) All non-residential and multi-family developments (*or other redevelopment areas that will impact the storm water flow*) shall construct detention facilities.





- (B) Residential developments shall construct detention facilities if it is determined that the downstream system does not have adequate hydraulic capacity for the proposed developed flow and the capacity of the downstream system cannot be increased to allow the conveyance of the proposed developed flows.
- (C) All development within the Squabble Creek, Buffalo Creek and Little Buffalo Creek watersheds will construct detention facilities and provide a flood study using hydrology and hydraulic models, to prove that the proposed development will not cause any increase in peak flood discharge rates and flood elevations at all computed points downstream of the proposed development. For Squabble Creek this study shall extend downstream to Lake Ray Hubbard, for Buffalo Creek it shall extend downstream through Rockwall Lake Dam, for Little Buffalo Creek it shall extend downstream to the crossing of Horizon Road (FM-3097).

### SUBSECTION 3.04.03 | TYPE OF DETENTION FACILITIES

The following detention facilities are to be utilized for detention.

- (A) Site of ½-Acre or Less
- (1) Underground
  - (2) On concrete Parking Surface (*maximum one [1] foot water depth*)
- (B) Site of Greater Than ½-Acre, On-site
- (1) Underground
  - (2) On concrete Parking Surface (*maximum one [1] foot water depth*)
  - (3) Detention Basin
    - Side slopes to be four (4) to one (1) [4:1] or flatter(*no fencing allowed*).
    - Area to be Landscaped
    - Retaining walls not allowed within detention pond
    - Maintained by Developer
    - Additional Amenities Preferred
    - Ownership Stays with Property Owner
    - Dams over five (5) foot to be approved by State. Dam must meet state dam safety guidelines.
- (C) Greater Than ½-Acre, Off-site Shared
- (1) Detention Basin Shared with Other Developments
    - May Expand Existing Pond
    - No Increase in 100-Year Flood Plain Elevation
    - Capacity Expanded Above Existing Water Surface
    - Need Engineering Study
  - (2) Flow to Regional Detention Basin
    - Regional facility manager (*owner of facility*) must approve improvements unless drainage is already accounted for in original design
    - Developer/s fund improvements to regional basin
    - Developer/s improves storm water conveyance system to basin (*based on fully-developed 100-year flow*)
    - Dams over five (5) foot to be approved by State. Dam must meet state dam safety guidelines.
    - Dam cannot be over 15-feet tall
    - Basins with water retention to have stored water depth of at least four (4) feet
    - Requires landscaping and amenity features (*Approved by Planning Department*)
    - Facility manager to assure good retained water quality
    - Trash collectors required at outfall structures
    - Side slopes to be four (4) to one (1) [4:1] or flatter.



- Developer/Owner owns and maintains basin
- Facility Manager to develop and perform maintenance program
- Underground (*preferred*), natural open channel (*existing creek with 100-year developed capacity*), Developer's to obtain additional drainage easement for 100-year developed flow area (*no concrete or gabion sidewalls*).
- Possible Pro-rata from other developments that utilize the basin

(3) Existing Lake

- Lake manager must approve
- Developer/s to fund improvements to lake
- Developer/s improves to the storm water conveyance system to lake (*developed 100-year flow*): Underground (*preferred*); Natural Open Channel (*existing creek with developed 100-year capacity*); Developers to obtain additional drainage easement for 100-year developed flow area; no concrete or gabion channel sidewalls
- Additional storage out of 100-year storage

(D) Existing Ponds

(1) Developer/s improve existing undesirable detention facilities

- Remove fencing where possible
- Provide concrete flume in bottom of pond
- Provide landscaping
- Improve maintenance access
- Reconstruct with underground system
- Remove pond by conveying storm water flow to shared detention facility without adverse impacts to other properties.

### SUBSECTION 3.04.04 | GEOMETRY, RESTRICTIONS, AND APPURTENANCES

- (A) Detention ponds shall have a side slope of four (4) to one (1) [4:1] or flatter. No retaining walls are allowed in detention ponds unless a variance is approved by the Planning and Zoning Commission in accordance with the procedures contained in [SECTION 09, EXCEPTIONS AND VARIANCES, OF ARTICLE 11, DEVELOPMENT APPLICATIONS AND REVIEW PROCEDURES, OF THE UNIFIED DEVELOPMENT CODE \(UDC\)](#) prior to the installation of the retaining walls. Retaining walls installed without an approved variance shall be removed.
- (B) The detention pond bottom grade shall be at a minimum of one (1) percent slope unless a detention/retention pond. A four (4) inch thick concrete low flow flume shall be installed from the pond's inlet structure/structures to the outfall structure.
- (C) All detention ponds and reserved shoreline shall have the appropriate amount of freeboard as called out in [TABLE 3.14, MINIMUM FREEBOARD REQUIREMENTS](#), from the 100-year water surface, based on flood inflows determined assuming fully-developed watershed conditions (*without consideration of any future upstream detention*), including incised ponds (*without embankment/dams*), or a higher design criterion if required by the State.
- (D) The State of Texas has jurisdiction of all dams, regardless of dam height or impoundment storage size, if they are classified by State regulations and guidelines with hazard classifications as "high – or significant-hazard". [*Reference: Texas Administrative Code, Title 30, Part 1, Chapter 299, Subchapter A, (a)(3)*]. Dams with maximum height of over five (5) feet must be approved by the State, unless the dam maximum height is less than 15-feet and a registered professional engineer licensed in Texas adequately shows, with an engineering study using the State of Texas Dam Safety guidelines and regulations, that a sudden breach of the dam during a major flood event, as specified and determined by the State's procedures, would not cause any significant increase in flooding or significant increase in flood damages as compared to a non-breach of the dam during a non-breach flood event. For dams permanently impounding water, the study should also determine the extent of additional flooding that would be caused by a sudden breach of the dam during non-flooding events. If the breach of the dam can be proven to not cause any significant flood damages (*other than to the dam embankment*), then it can be proven to be classified as a "low-hazard" dam by State definition, and the dam may be exempt, at the City Engineer's discretion, from requiring State review and approval. However, regardless of whether the dam design is reviewed by the State, all dams, regardless of size, must have an emergency spillway and be designed, constructed, maintained, and operated per State Dam Safety Guidelines, including emergency action management. The maximum height of the dam, hazard classifications, and "significant" increased flooding (*as related to embankment breach analyses*) are determined based on the State's definitions and regulations.



- (E) No detention is allowed in the FEMA 100-year nor local 100-year fully developed floodplain.
- (F) No detention pond is allowed with outlet elevation below a receiving stream's or channel's 100-year fully developed flood elevation.
- (G) No franchise utilities (*Gas, Electric, Cable, Telephone, Communications, etc.*), public water lines and wastewater lines are allowed in detention ponds, and detention easements.
- (H) Underground detention systems must be a fully enclosed pipe system.
- (I) The detention pond shall have an emergency overflow in case the main outfall structure gets clogged. The emergency overflow shall be sized to pass the fully-developed 100-year flood at a minimum, or greater based on State Dam Safety requirements. City-approved erosion protection shall be placed along the length of the emergency overflow to the flowline of the receiving structure, creek or channel, and extended as necessary to prevent erosion of the dam structure.
- (J) The detention systems are to be installed and verified for design compliance along with the associated storm sewer and outfall structures and drainage channels, prior to any paving operations. All constructed detention ponds, drainage ways, and open channels shall have the sides and bottom stabilized with sod or anchored seeded matting prior to any paving construction (including building slab). The matting or sod shall be anchored at high velocity locations if deemed necessary. Erosion protection is to be placed at the pond's outflow structure along with any associated erosion BMP's noted on the erosion control plan.
- (K) Sometimes a detention facility will be utilized by several developments, and then a pro-rata agreement/detention masterplan may be entered into with the development constructing the facility and the other developments utilizing the facility Without a pro-rata agreement/detention master plan of all parties in advance of construction of all combined developments, no new proposed development will be allowed to take credit for any "over detention" of a previous development or the reduction of discharges from a previous development within the watershed in the determination of detention requirements.
- (L) Detention pond outfall structures shall be fitted with a trash rack.
- (M) Detention ponds shall be designed to be fully emptied within 24-hours.
- (N) Detention ponds shall be designed, graded and maintained so that standing water does not remain after the designed discharge timeframe.
- (O) Detention ponds shall be irrigated.
- (P) Detention ponds for new single-family residential subdivisions shall be located within a HOA maintained lot. Detention ponds and associated easements may not be located on a non-HOA lot. Non-single family residential development's detention system shall be maintained, repaired, and replaced by property owner.

#### SUBSECTION 3.04.05 | DETENTION CALCULATIONS

The detention design calculations and outfall rating curves shall be included in the plans and flood study. Increased peak discharges from the detention basin are not allowed for the 5-year, 10-year, 25-year, 50-year and 100-year frequency floods based on existing off-site conditions.

#### SUBSECTION 3.04.05.01 | METHODOLOGY

Detention facilities that have a drainage area of less than 20-acres shall be sized using the *Modified Rational Method*. If the drainage area is equal to or greater than 20-acres then the *Unit Hydrograph Method* shall be used. The *Modified Rational* method may be used for drainage areas more than 20-acres but the *Unit Hydrograph Method* must be performed as a comparison. The more conservative of the two methods shall be used to design the pond (*and technical documentation of both methods should be provided to the City for review and verification of the most conservative method selected*).

The following conditions shall be used when implementing the *Modified Rational Method*.

- (A) The proposed development will construct detention facilities to detain the increase in runoff between the existing 100-year flows (*C-undeveloped, TC = 20 minute*) and the fully developed flows (*C – depends on zoning, TC = 10 minute*). The "C" value is based on zoning, not pervious/impervious areas. Large area of park land dedicated to City can be considered by City in this value.
- (B) Storm rainfall intensity (inch/hour) for different storm years shall be as shown in [TABLE 3.15](#).



TABLE 3.15: STORM RAINFALL INTENSITY (INCHES/HOUR)

	100 YEAR	50 YEAR	25 YEAR	10 YEAR	5 YEAR	2 YEAR
10 MINUTES	9.8	9.0	8.3	7.1	6.1	5.3
15 MINUTES	9.0	8.1	7.5	6.5	5.5	4.5
20 MINUTES	8.3	7.5	6.6	5.9	4.9	3.9
30 MINUTES	6.9	6.1	5.5	4.8	4.1	3.3
40 MINUTES	5.8	5.2	4.6	4.0	3.4	2.6
50 MINUTES	5.0	4.5	4.0	3.5	2.8	2.3
60 MINUTES	4.5	3.9	3.5	3.0	2.6	1.9
70 MINUTES	4.0	3.7	3.3	2.8	2.4	1.8
80 MINUTES	3.7	3.5	3.1	2.6	2.3	1.7
90 MINUTES	3.5	3.3	2.9	2.5	2.1	1.6
100 MINUTES	3.4	3.0	2.7	2.4	1.9	1.5
110 MINUTES	3.2	2.9	2.5	2.3	1.8	1.4

(C) The following is an example calculation on how the *Modified Rational Method* is performed to determine detention volume:

### MODIFIED RATIONAL METHOD DETENTION BASIN DESIGN

*Given:* A ten (10) acre site, currently agricultural use, is to be developed for townhouses. The entire area is the drainage area of the proposed detention basin.

*Determine:* Maximum release rate and required detention storage.

#### Solution:

(A) Determine 100-year peak runoff rate prior to site development. This is the maximum release rate from site after development.

*NOTE:* WHERE A BASIN IS BEING DESIGNED TO PROVIDE DETENTION FOR BOTH ITS DRAINAGE AREA AND A BY-PASS AREA; THE MAXIMUM RELEASE RATE IS EQUAL TO THE PEAK RUNOFF RATE PRIOR TO SITE DEVELOPMENT FOR THE TOTAL OF THE AREAS MINUS THE PEAK RUNOFF RATE AFTER DEVELOPMENT FOR THE BY-PASS AREA. THIS RATE FOR THE BY-PASS AREA WILL VARY WITH THE DURATION BEING CONSIDERED.

(B) Determine inflow hydrograph for storms of various durations in order to determine maximum volume required with release rate determined in Step 1.

*NOTE:* INCREMENTALLY INCREASE DURATIONS BY 10 MINUTES TO DETERMINE MAXIMUM REQUIRED VOLUME. THE DURATION WITH A PEAK INFLOW LESS THAN MAXIMUM RELEASE RATE OR WHERE REQUIRED STORAGE IS LESS THAN STORAGE FOR THE PRIOR DURATION IS THE LAST INCREMENT.

### PROCEDURE

#### STEP 1. PRESENT CONDITIONS (AGRICULTURAL)

$$Q = C \cdot I \cdot A$$

$$C = 0.35$$

$$T_c = 20 \text{ MINUTES}$$

$$I_{100} = 8.3 \text{ INCHES/HOUR}$$

$$Q_{100} = (0.35)(8.3)(10 \text{ ACRES}) = 29.05 \text{ CFS (MAXIMUM RELEASE RATE)}$$

#### STEP 2. FUTURE CONDITIONS (TOWNHOUSES)

$$C = 0.80$$

$$T_c = 10 \text{ MINUTES}$$

$$I_{100} = 9.8 \text{ INCHES/HOUR}$$

$$Q_{100} = (0.80)(9.8)(10 \text{ ACRES}) = 78.40 \text{ CFS}$$

Check various duration storms:

MINUTES	I	Q
15	9.0	(0.80)(9.0)(10 acres) = 72.0 CFS



20	8.3	(0.80)(8.3)(10 acres) = 66.4 CFS
30	6.9	(0.80)(6.9)(10 acres) = 55.2 CFS
40	5.8	(0.80)(5.8)(10 acres) = 46.4 CFS
50	5.0	(0.80)(5.0)(10 acres) = 40.0 CFS
60	4.5	(0.80)(4.5)(10 acres) = 36.0 CFS
70	4.0	(0.80)(4.0)(10 acres) = 32.0 CFS
80	3.7	(0.80)(3.7)(10 acres) = 29.6 CFS
90	3.5	(0.80)(3.5)(10 acres) = 28.0 CFS
100	3.4	(0.80)(3.4)(10 acres) = 27.2 CFS
110	3.2	(0.80)(3.2)(10 acres) = 25.6 CFS

*Maximum Storage Volume* is determined by deducting the volume of runoff released during the time of inflow from the total inflow for each storm duration.

MINUTES	INFLOW (IN)	OUTFLOW (OUT)	STORAGE VOLUME (IN-OUT = SV)
10	(10)(78.4 CFS)(60 SEC/MIN) = 47,040 CF	(0.5)(20 MIN)(29.05 CFS)(60 SEC/MIN) = 17,430 CF	29,610 CF
15	(15)(72.0 CFS)(60 SEC/MIN) = 64,800 CF	(0.5)(25 MIN)(29.05 CFS)(60 SEC/MIN) = 21,788 CF	43,012 CF
20	(20)(66.4 CFS)(60 SEC/MIN) = 79,680 CF	(0.5)(30 MIN)(29.05 CFS)(60 SEC/MIN) = 26,145 CF	53,535 CF
30	(30)(55.2 CFS)(60 SEC/MIN) = 99,360 CF	(0.5)(40 MIN)(29.05 CFS)(60 SEC/MIN) = 34,860 CF	64,500 CF
40	(40)(46.4 CFS)(60 SEC/MIN) = 111,360 CF	(0.5)(50 MIN)(29.05 CFS)(60 SEC/MIN) = 43,575 CF	67,785 CF
50	(50)(40.0 CFS)(60 SEC/MIN) = 120,000 CF	(0.5)(60 MIN)(29.05 CFS)(60 SEC/MIN) = 52,290 CF	67,710 CF
60	(60)(36.0 CFS)(60 SEC/MIN) = 129,600 CF	(0.5)(70 MIN)(29.05 CFS)(60 SEC/MIN) = 61,005 CF	68,595 CF
70	(70)(32.0 CFS)(60 SEC/MIN) = 134,400 CF	(0.5)(80 MIN)(29.05 CFS)(60 SEC/MIN) = 69,720 CF	64,680 CF
80	(80)(29.6 CFS)(60 SEC/MIN) = 142,080 CF	(0.5)(90 MIN)(29.05 CFS)(60 SEC/MIN) = 78,435 CF	63,645 CF
90	(90)(28.0 CFS)(60 SEC/MIN) = 151,200 CF	(0.5)(100 MIN)(29.05 CFS)(60 SEC/MIN) = 87,150 CF	64,050 CF
100	(100)(27.2 CFS)(60 SEC/MIN) = 163,200 CF	(0.5)(110 MIN)(29.05 CFS)(60 SEC/MIN) = 95,865 CF	67,335 CF
110	(110)(25.6 CFS)(60 SEC/MIN) = 168,960 CF	(0.5)(120 MIN)(29.05 CFS)(60 SEC/MIN) = 104,580 CF	64,380 CF

The maximum volume required is 68,595 CF at the 60-minute storm duration.

#### **SUBSECTION 3.04.05.02 | OUTFALL STRUCTURES**

Detention out fall structures shall be multi-staged and designed to detain the 5-year, 10-year, 25-year, 50-year, and 100-year storm events without increasing the peak discharge. A chart shall be furnished by the design engineer showing the allowable flows verses the actual flows through the detention pond outflow structure for 5-year, 10-year, 25-year, 50-year, and 100-year storm events.

When the design is based on the Modified Rational Method, outfall structures shall be designed in accordance to the equations established in *Hydraulic Engineering Circular No. 22, Urban Drainage Design Manual (HEC-22)*. The Engineer shall include all calculations/ equations for the outfall structure in the plans, including each stage of the structure (5-year, 10-year, 25-year, 50-year, and 100-year storm events).

When the detention pond and outfall structure is designed using a *Unit Hydrograph Method (hydrology model)* and a hydraulic model is being prepared (such as for a detention pond with dam located across a stream for which flood elevations will be determined), the outfall structure discharges may be determined with the hydraulic model. All flow characteristics and conditions of the outfall structure should be adequately represented in the hydraulic model or other calculations to account for orifice flow conditions, weir flow conditions, and full-pipe and partially-full pipe flow conditions for all discharge openings, pipes, and overflow areas of both the discharge structure and the dam. The resulting discharge versus pond flood elevation data should be adequately represented in the hydrology model to ensure that the flood elevations computed with the hydrology model reasonably agree with those computed by the hydraulic model for all ranges of discharges.

City approved erosion protection shall be placed around the outfall structure and shall extend downstream the entire flow path length to the flowline of the receiving structure, creek or channel. The erosion protection shall extend to two (2) feet above the 100-yr water surface elevation.



### SECTION 3.05 | FLOODPLAIN STUDIES, RECLAMATION, AND MODIFICATION

All floodplain studies, reclamation, modification, flood boundary delineations and design of structures within or adjacent to creeks or streams shall meet the following guidelines set forth in this section and the most current *Flood Hazard Damage Prevention and Control Ordinance*.

- (A) A qualified professional engineer licensed in the State of Texas shall prepare a flood study report documenting all data, methodology, and assumptions used in the study. The study report shall be properly signed and sealed, and include a concluding statement certifying that the hydrologic and hydraulic study is based on standard engineering practice, that the project is constructed, or proposed to be constructed, as shown in certified engineering plans used in the study such that there will be no adverse increases in flooding or flood damages on other properties and that the project meets the requirements of all parts of the City's current *Flood Hazard Damage Prevention and Control Ordinance*.
- (B) Flood studies shall follow the general procedures set by FEMA for applying for a LOMR or CLOMR, including hydrologic and hydraulic modeling; drainage area workmap; floodplain workmap; annotated FIRM; FEMA forms; and complete technical documentation of all data used in the study, including, but not limited to, calculations of times of concentrations or lag times and calculations of other runoff parameters such as NRCS curve numbers. Other requirements are contained in *Unit Hydrograph Method* Section of these standards. These procedures shall be performed even for flood studies not being submitted to FEMA.
- (C) Floodplains and watersheds shall be modeled using standard practice engineering models that are public domain. The use of computer modeling software that is not public domain will require approval by the City Engineer. [*The most recent versions of HEC-HMS and HEC-RAS are currently the City's required hydrology and hydraulic models for flood studies. The use of these models is required in cases where a conversion from older models is desired or in previously-unstudied areas where new models are to be created*].
- (D) All design elevations shall be based on computed flood elevations using flood discharges for 100-year projected fully-developed watershed conditions, including the effects of changes in storm water runoff and effects of encroachment and changes in flood valley storage caused by the proposed project.
- (E) All flood study models shall utilize the most current available models from the City or FEMA as base models (*if available*) and shall incorporate all additional modifications that have occurred since the last update of these models. Conversion of base models to newer approved digital models is allowed, as noted below.
- (F) Results of hydrology and floodplain hydraulic computer models shall be summarized in tabular form, to show differences in computed 100-year flood discharges and flood elevations. The computer model results to be included in the comparison tables include:
  - (1) The original effective base hydrology and hydraulic models, if available, as provided by the City or FEMA.
  - (2) Improved modeling procedures may be allowed and included, such as conversion of original models to newer versions of computer modeling software, such as conversion of HEC-2 models to HEC-RAS and conversion of TR-20 or HEC-1 models to HEC-HMS. Conversion to computer software that is not free public domain software and that is not on FEMA's approved list of computer modeling software must receive approval by the City Engineer. Results of conversion to improved modeling should be performed prior to any updates or corrections to the model data and compared in tabular form with the original base model results.
  - (3) Corrected hydrologic and hydraulic models (*commonly referred to as "corrected effective" models by FEMA procedures*) to include any improved data or needed corrections, such as new surveyed floodplain cross sections, inclusion of additional cross sections, or improved topographic mapping, but should not include and man-made changes to the watershed or floodplain.
  - (4) Pre-project hydrologic and hydraulic models, to update the computer models by adding man-made changes that have occurred in the watershed and floodplain since the date of the original effective base models. [*If there are no updates based on man-made changes, then the "corrected effective" and "pre-project" models are the same*].
  - (5) Post-project hydrologic and hydraulic models, to include all changes that are included in the pre-project models, plus hydrologic and hydraulic characteristics that are representative of changes based on the project's proposed final completed construction. The post-project hydrology should include changes in runoff conditions related to modifications of land cover and grading, changes in times of concentration or lag times, alteration of stream channels and floodplain areas (*including changes in floodplain valley storage and changes in flow velocities*), changes in drainage areas and drainage patterns, and any proposed mitigation to prevent increases in flood discharges. The post-project hydraulic models should include effects to floodplain hydraulic characteristics, including changes in floodplain and channel configuration, such as encroachments, excavations, channelization, proposed hydraulic structures, clearing of areas that will be continually maintained, and changes in hydrology (*flood discharges*). The effects of temporary clearing of vegetation in areas that will not be maintained should not be included.



- (6) Hydrologic and hydraulic computer modeling must be provided for both existing watershed conditions (*both pre-project and post-project conditions*), with summary comparisons of various steps (*“a” through “e”, above*) shown in tabular form, to include computed 100-year discharges and flood elevations. The results of hydrology and hydraulic post-project models will be compared with results of pre-project models to verify compliance of City Standards requiring no increased flooding on other properties. Additionally, hydrology and hydraulic models must be provided based on fully-developed watershed conditions with the proposed project. The results of the fully-developed condition models, will be used to determine compliance with the City’s design elevation standards. When construction of a project will be in phases, the City Engineer may require flood studies to be submitted for each phase.
- (G) When transferring discharges computed by the hydrology models as input data entered into the hydraulic models, round-off of discharges is allowed only to the nearest one (1) CFS. All hydrology models should be set to compute discharges to the nearest one (1) CFS and flood elevations (*such as in ponds*) to the nearest 0.01-feet. All hydraulic models should be set to compute flood elevations to the nearest 0.01 ft. Locations of flow changes in the hydraulic model should be carefully determined to avoid undue under-calculation of flood elevations. For example, in order to prevent unreasonable under-calculations of flood elevations along portions streams, discharges computed at sub-basin outlets along a stream should normally be used in the hydraulic model for a reasonable extended portion of the upstream floodplain reach, in order to avoid neglecting all of the lateral inflow within the upper stream reach in the hydraulic model computations.
- (H) The completed flood study, including detailed technical documentation; printed hydraulic and hydrological model input data and output results, digital model files (*as listed in “F”, above, for both existing and projected future fully-developed watershed conditions*), supporting calculations, drainage area maps, floodplain boundary maps, certification statement (*as noted in “A.”, above*) and all CAD/GIS data shall be submitted to the City for review.
- (I) The watershed work map(s) should include the following:
- (1) Multiple watershed work maps may be submitted for pre-project and proposed project conditions, as long as all of the following items are provided.
  - (2) Total watershed drainage area and sub-basin drainage delineation boundaries, including those representative of the original base hydrology model, the corrected drainage delineations (*if any*), and proposed project changes in drainage delineations and any added sub-basins. All sub-areas should be labeled in agreement with sub-area labels used in the hydrology models.
  - (3) Topography overlaid on high-resolution aerial photography, with elevation contour labeling.
  - (4) Delineation of hydrologic soil groups and land cover conditions (*these may be included on a separate map, with drainage delineations*).
  - (5) Property boundaries of the tract of land where the proposed project is located, including any proposed division lines for the current and future project phases.
  - (6) Proposed project, with proposed grading and changes in land cover.
  - (7) Stream channel centerline flow path, with flow direction indicated.
  - (8) Flow path used in determining times-of-concentration or lag times (both pre-project and modifications based on proposed construction).
  - (9) Title block, legend, north arrow, and bar scale.
- (J) The floodplain work map(s) should include the following:
- (1) Multiple floodplain work maps may be submitted, as long as all of the following items are provided.
  - (2) Floodplain cross sections, with location and orientation relative to the floodplain, with labels in agreement with the stations referenced in the hydraulic models. If the study involves a stream that has been previously studied, stream stationing should be in general agreement with stationing used in the previous study. For streams with no previous flood studies, the stream stationing should be based on channel distance upstream from the stream’s point of termination (downstream location of where the stream enters a larger receiving stream or major lake (such as Lake Ray Hubbard).
  - (3) Topography overlaid on high-resolution aerial photography, with elevation contour labeling.
  - (4) Floodplain boundaries and flood elevations for the 100-year flood using discharges for both pre-project existing watershed conditions and modifications based on proposed project discharges.
  - (5) Floodplain boundaries identified on the Flood Insurance Rate Maps as Special Flood Hazard Areas, and floodplain boundaries from previous studies (*if available from the City*) with 100-year flood elevations.



- (6) Floodplain boundaries and flood elevations for the 100-year flood based on projected fully-developed watershed conditions, with the proposed project.
  - (7) Stream channel centerline (*invert*) with direction of flow indicated (*for both pre-project and any changes in stream channel centerline based on the proposed construction*).
  - (8) Property boundaries of the tract of land where the proposed project is located, including any proposed division lines for the current and future project phases. Include drainage easements and erosion hazard setbacks.
  - (9) Title block, legend, north arrow, and bar scale.
- (K) In order for the City to maintain and update their hydrology and hydraulic computer models, after construction is completed, the developer's engineer must update and submit to the City their final certified flood study report, with hydrology and hydraulic models, along with all supporting calculations, maps, report, AutoCAD (.*dwg files*), and GIS files and other exhibits to adequately represent as-built conditions. If the project has been submitted to FEMA, the updated models and revisions to flood study reports should include all modifications that were approved by FEMA.
- (L) The City Engineer will determine whether the proposed development will require a LOMR or CLOMR. All documentation prepared for submitting to FEMA (*LOMRs/CLOMRs*) will be reviewed by the City. The City will not approve the flood study prepared for a LOMR, nor sign a LOMR application form, until construction grading associated with the LOMR has been completed, certified "as-built" plans are submitted to the City, construction has been verified by onsite inspection(s), and all required Local, Federal, and State permits and approvals have been received. Lots that overlap the existing floodplain will not be permitted until final LOMR is approved by City and FEMA and effective removing the lots from the floodplain.
- (M) The City will utilize an engineering consulting firm to assist City staff in the review of a flood study. The cost of this consultant review shall be borne by the developer, engineer, or property owner submitting the flood study. Before the review begins, the developer, engineer, or property owner submitting the flood study shall deposit with the City funds required for the review of the flood study. The City shall disburse the funds to the consulting engineer as the review progresses. Should the consultant fees exceed the initial estimate, the developer, engineer or property owner submitting the flood study shall be informed of the shortage to complete the flood study review. Additional funds will then be deposited with the City by the developer, engineer or property owner submitting the flood study to cover the remaining reviews before the review of the study resumes. Any unused funds to be reimbursed to the developer, engineer or property owner submitting the flood study.

## SECTION 3.06 | STORM DRAINAGE MANAGEMENT PLAN

### SUBSECTION 3.06.01 | GENERAL

Storm drainage facilities shall include all elements of a drainage system consisting of streets, alleys, storm drains, channels, culverts, bridges, swales and any other facility through which or over which storm water flows, all of which the City must have a legal access, either in the form of a dedicated right-of-way, floodway or drainage easements.

### SUBSECTION 3.06.02 | SITE DRAINAGE

All new subdivisions shall provide as part of the subdivision review process a complete storm drainage management plan. This plan will include, but not be limited to, the following: a complete review of all on-site, upstream and downstream drainage within the impacted watershed; determine all on-site and downstream drainage facility improvements due to the increased runoff from the proposed development and future upstream and downstream developments; and contain calculations necessary to determine compliance with the Standards of Design herein. Detention will be required if the downstream storm system is not capable of handling the proposed drainage flows and areas designated in [SUBSECTION 3.04.02](#) of this document. The plan shall be done, using current zoning conditions or land use prescribed by the City's Land Use Plan (whichever creates the greatest storm water runoff), with maximum development considered throughout the watershed. The storm drainage plan shall show all necessary improvements with flow data provided at each point of interception of water. As part of the storm drainage plan, the developer shall show a lot grading plan to direct all water to proper intersection points prohibiting cross flow of water from lot to lot. Drainage may not be impeded or blocked from following natural paths, causing standing water or damage on adjacent property. All upstream discharge shall be intercepted and carried through the proper intersection points prohibiting cross flow of water from lot to lot. All upstream discharge shall be intercepted and carried through the proposed development in compliance with the Standards of Design herein. Upstream drainage shall not cross into or through any single-family lot. It shall be collected in an engineered designed ditch/swale or pipe system and conveyed downstream. All discharge from the proposed development shall be designed in accordance with the Standards of Design herein with all necessary improvements being installed by the developer to protect downstream property and adjacent properties from damage. The determination of necessary





improvements to existing drainage facilities downstream of a proposed development shall be reviewed by the City Engineer for compliance and adequacy. If a storm drainage plan has been completed prior to new proposed development in question, the developer may use this plan if the City Engineer deems the existing plan is adequate.

### SUBSECTION 3.06.03 | SUBDIVISION DEVELOPMENT

All subdivision developments shall be built in complete compliance with a storm drainage plan as outlined herein. All lots shall be graded at the time of development in accordance with the plan. All grading shall not exceed a slope of four (4) to one (1) [*i.e.* 4:1] unless approved by the City Engineer. Approved erosion control shall be provided as part of the development construction on any or all lots within the development to protect the drainage, lot development and adjacent property.

The finish building pad for all subdivision developments shall be elevated to a minimum of one (1) foot above the crown of the road. In no circumstance shall a building pad and finish floor of any structure be placed below any adjacent street or alley invert grade. An open space/HOA lot may not be used as a buffer from an adjacent street or alley to alleviate this requirement unless approved by the City Engineer.

### SUBSECTION 3.06.04 | CONSTRUCTION EROSION CONTROLS

*Construction Erosion Controls* shall follow the guidelines set out in NCTCOG's *iSWMTM Technical Manual: Construction Controls April 2010, Revised September 2014* or more recent revision.

In order to address the requirements of pollution reduction at construction sites, a variety of controls should be employed to reduce soil erosion, reduce sediment loss from the site, and manage construction-generated waste and construction related toxic materials. Controls consist of both temporary and permanent methods to reduce pollution from a construction site. The majority of controls address loss of soil from the site. Soil loss in the form of erosion and sediment due to storm events and wind constitute the majority of pollution generated from construction sites. Controls that address erosion and sediment are typically more site specific than waste and toxics management. Erosion and sediment controls are dependent on-site slopes, drainage patterns and drainage quantities along with other site-specific conditions. Materials and waste management consists primarily of "good housekeeping" practices which are dependent on the type of construction and the quantity and type of building materials.

Control measures shall follow the control selection guide set forth in the iSWM manual and TCEQ. Control measures from each of the three categories; *Erosion Controls*, *Sediment Controls* and the *Material and Waste Controls* shall be used in the design of an *Erosion Control Plan* for a site. Standard details called out in *Division 1000 of NCTCOG's Standard Specifications and Standard drawings* and the City details shall be utilized as well in the development of an erosion control plan.

Control measures (*such are silt fences, inlet protection, rock berms, etc.*) shall be removed from the site once grass cover has been established to an efficient level. Types of erosion control may be removed depending on amount of disturbed area remaining. Erosion control shall remain and be maintained when the overall project has reached the minimum amount of disturbed area, one (1) acre. Grass cover shall be determined by the [VEGETATION](#) section of these *Standards*.

Erosion control for a development shall remain until the phase has the minimum disturbed area, one (1) acre, for the overall phase, not individual lots. By approval of City Engineer, erosion control may remain in place after phase is complete in anticipation of future phases.

Erosion control shall be inspected by the contractor weekly, and before and after rain events. Deficiencies shall be corrected within a timely manner. If a deficiency is identified before a rain event, it shall be corrected before the end of the day or before the rain begins. Types of deficiencies include, but not limited to, holes or tears in silt fencing, fallen silt fencing, debris or sediment clogging erosion control device, rock check dams or construction entrance rock sedimented over or covered, and required inlet protectors missing. Silt fence, construction entrance, and all other approved construction site erosion control devices shall be maintained to SWP3 and City Engineering Inspector requirements.

- (1) Construction Entrance. No crushed or recycled concrete is allowed and rock must be a minimum of 12-inches thick using well graded rock with minimum diameters of four (4) to six (6) inches.
- (2) Silt Fence. No wooden stakes to be allowed on any erosion control device. Silt fence should not be installed within a 100-year floodplain.
- (3) Hay Bales. No hay bales to be allowed as an erosion control device.



- (4) Performance. Erosion from construction sites can be a significant water quality problem. Developing areas are cleared of vegetation during construction leaving the soil exposed and susceptible to erosion. Runoff then transports eroded sediment from these areas and deposits it downstream. The accumulation of silt in streams and ponds is a form of water pollution that is unattractive and impedes drainage.

Prevention is a key aspect of erosion control. Many of the control methods presented herein can be placed in a manner that will protect highly erodible areas such as steep slopes. The prevention of erosion requires prior planning to ascertain the placement of selected control methods. The rewards of this planning will be a significant reduction in soil loss. Not only can soil loss be prevented, but eroded soil can be recovered on the construction site and used for fill.

The particulate material in construction site runoff is generally heavier and larger than particulates in urban runoff. These attributes facilitate the removal of the material whether the removal is by settling in a sediment trap or by filtration through a filter fence. Temporary sediment traps, filters and routing devices can effectively control erosion for construction sites if properly applied. These methods are even more effective when permanent management techniques are used in an effort to control temporary increases in sediment loads.

Keep dirt/mud/debris off of all public streets and fire lanes. It is required to have sufficient equipment and materials on-site to safely remove dirt/mud/debris from the public streets and fire lanes. Such equipment includes but not limited to: traffic control items, brooms, shovels, and personal protection equipment.

Required documents and permits prior to construction:

- Storm Water Pollution Prevention Plan (SWP3). A copy of the executed SWP3 is to be submitted electronically to the City, if the project disturbs one (1) acre or more of land.
- Storm Water Notice of Intent (NOI). An electronic copy of the executed NOI will be required to be submitted to the City, if the disturbed area of land of the project is five (5) acres or more, or if the project will disturb land one (1) or more acres, but less than five (5) acres and is a part of a larger common plan of development or sale that will disturb 5-acres of land.
- TPDES General Permit No. TXR 150000. Provide an electronic executed copy of the general permit to the City if the project is one (1) acre and less than five (5) acres of disturbed land.
- Administrative Policy (97-03). An executed copy of the Administrative Policy shall be submitted to the City.

### SUBSECTION 3.06.05 | LOT DEVELOPMENT

All lot developments shall include a drainage plan preventing all diversion of water from the approved path of discharge. The builder at the time of permit application shall furnish a grading plan in compliance with the appropriate chapter of the building code adopted by the City, the as-built grading plan for the development, and the as-built storm drainage plan approved for that particular development. All structures or mechanical equipment installed after site/civil construction shall not block or divert drainage. If the re-grading of a lot is necessary, the builder shall be required to furnish a new drainage plan indicating the diversion and rerouting of the affected storm water. When the re-grading of a lot prevents the drainage from flowing to the proper structures as designated in the drainage plan, then the builder will furnish a registered engineer's review for adequacy of existing structures to which the water is diverted. If improvements are necessary to provide for adequate drainage due to re-grading of a lot, then the improvement must be made at the builder's expense before a grading permit or other permits for construction will be issued by the City. The City Engineer will review the information submitted for compliance with the approved grading and drainage management plan. Accepted City streets are not to be used as an erosion control. No inlet protection is allowed in an accepted City street.

- (A) Off-Site Cost Sharing. The developer shall be fully responsible for the construction of off-site drainage improvements necessary for his/her subdivision and the surrounding area, unless other provisions are approved by the City Council. Provisions for reimbursement of cost in excess of those necessary to serve the development, and any other provisions, shall be made a part of a facilities agreement. For any subsequent development utilizing such facilities, any cost due to prior developers shall be pro-rated based on the increased contribution of storm water runoff. Such pro-rated amounts shall be made a part of any subsequent agreement, collected by the City and repaid to the original developer making such improvements.

The original developer shall provide the City with acceptable documentation of actual construction cost from which calculation of reimbursable amounts will be made for inclusion in the facilities agreement.

- (B) Exemptions. When a development is of two lots or less and in the City Engineer's opinion does not affect existing drainage facilities or affect the adjacent property, the City Engineer may allow the developer to waive any off-site pro-rata costs.



- (C) All City rights-of-way shall be sodded where disturbed. No artificial grass is allowed in any City right-of-way and/or easements.
- (D) Before acceptance of streets and alleys silt fencing shall be placed at the back of curb/edge of all pavement.





## CHAPTER 4 | VEGETATION

### SECTION 4.01 | GENERAL

All seeding, sodding and fertilizer requirements are to be done in accordance with the North Central Texas Council of Governments (NCTCOG) *Standards and Specifications (Under Item 202)* as modified by the City of Rockwall.

### SECTION 4.02 | COVERAGE

The developer shall establish grass and maintain the seeded area, including watering, until a *Permanent Stand of Grass* is obtained at which time the project will be accepted by the City. A *Stand of Grass* shall consist of 75% to 80% coverage of the whole project area and a minimum of one (1) inch in height as determined by the City. There shall not be more than one (1) acre of land without proper grass coverage at the time of City acceptance. Re-seeding will be required in all washed areas and areas that have not established.

All City rights-of-way shall be sodded if disturbed. No artificial grass is allowed in any City right-of-way and/or easements.

### SECTION 4.03 | PLANTING SEASON

TYPE NO.	VARIETY	HULLED OR UNHULLED	WEIGHT/ACRE	PLANTING SEASON
TYPE I	BERMUDA GRASS	HULLED	50 LBS/ACRE	APRIL THROUGH JUNE
TYPE II	ANNUAL RYE GRASS	N/A	40 LBS/ACRE	SEPTEMBER THROUGH MARCH
TYPE III	BERMUDA GRASS	UNHULLED	50 LBS/ACRE	JANUARY THROUGH MARCH & JULY THROUGH AUGUST

### SECTION 4.04 | ADDITIONAL INFORMATION

For a public utility less than ten (10) inches in size no tree shall be planted within five (5) feet (*horizontally*) of the utility and for a utility greater than or equal to ten (10) inches in size no tree shall be planted within ten (10) feet (*horizontally*) of the utility. If trees are approved by the Planning and Zoning Department and/or Planning and Zoning Commission to be within the right-of-way then a City approved root barrier will be required to be installed in order to keep roots from degrading the pavement structure. Vegetation over two (2) feet in height shall not be planted in any visibility easement or potential sight visibility (*including medians*).





## CHAPTER 5 | WATER AND WASTEWATER SYSTEMS

### SECTION 5.01 | GENERAL REQUIREMENTS

The design and construction of the water and wastewater system to serve the development shall be in accordance with good engineering principles, with these *Standards of Design and Construction*, and the *Standard Details* and with the requirements of the Texas Commission on Environmental Quality (TCEQ).

All on-site and off-site water and wastewater mains shall be sized and located to conform to projected demands in accordance with the current *Water Master Plan* and *Wastewater Master Plan* and the computer model with regard to the impact of each development on the existing and proposed water system. The alignment of future water and wastewater lines in the *Master Water and Wastewater Plans* may vary depending on design or layout. The water and wastewater lines in the Master Plans shall be minimums and should connect to the systems shown in the Plans.

No construction shall commence prior to the approval of the plans and specifications by the City.

The term “water main” shall refer to a water system that water meters, hydrants, and fire lines are connected to. Water mains may be located on private property but shall be within an easement and maintained by the City.

The term “wastewater main” shall refer to a wastewater system that serves more than one (1) property. Wastewater mains may be located on private property but shall be within an easement and maintained by the City. If a system serves only one (1) property and is located on private property it shall be a private sewer service and not a wastewater main and therefore considered private unless to serve off-site properties. Manholes or cleanouts on a sanitary sewer line does not indicate or require the system to be a wastewater main.

Water and wastewater mains should not cross a single-family lot unless along a street right-of-way within an easement. Mains crossing between rights-of-way within a residential subdivision shall be within right-of-way or within an easement, within a HOA owned and maintained lot.

#### SUBSECTION 5.01.01 | SYSTEM CAPACITY STUDIES

A *Water and Wastewater System Capacity Study* shall be performed for all developments or re-developments that propose a change in existing land use (*change in density or higher water and sewer usage*) that does not conform to the City’s current *Water and Wastewater System Master Plan*.

The City will utilize an engineering consulting firm to assist City staff in performing *Water and Wastewater System Capacity Studies*. The cost of this study, by the consultant, shall be borne by the developer, engineer, or property owner requesting the proposed change in land use. Before the study begins, the developer, engineer, or property owner submitting for a change in land use shall deposit with the City for the reviews. The City shall disburse the funds to the consulting engineer as the study progresses. Should the consultant fees exceed the initial estimate, the developer, engineer or property owner submitting for the change in land use shall be informed of the shortage for the consultant engineer to complete the study. Additional funds will then be deposited with the City by the developer, engineer or property owner to cover the remaining reviews. Any unused funds to be reimbursed to the developer, engineer or property owner submitting for a change in land use. If review process is performed by City staff, the City will submit a cost estimate for the study at time of the initial submittal.

#### SUBSECTION 5.01.02 | CONNECTIONS FOR FUTURE ADJACENT DEVELOPMENTS

All development shall accommodate future adjacent and upstream/downstream developments by extending water and wastewater lines across the proposed development in order to create water and wastewater systems connectivity. This connectivity will be provided for an ease of future development and limited disturbance to existing developments. These extensions of the water and wastewater facilities shall match the City’s *Water Master Plan* and *Wastewater Master Plan*.

If the property adjacent to the proposed development is a Utility owned or City owned property, extension may be required across the subject property.



### SUBSECTION 5.01.03 | EASEMENTS

If a water or wastewater main is located on private property the mains shall be within an easement that conforms to the minimum width in [TABLE 5.1](#). The utility shall be centered within the easement, or have a minimum of half the required easement width on both sides of utility.

TABLE 5.1: MINIMUM WIDTH FOR WATER AND WASTEWATER LINE EASEMENTS

		MINIMUM EASEMENT WIDTH (FT)	
CONDUIT SIZE	<= 48" DIAMETER	20'	
	> 48" DIAMETER	APPROVAL CITY ENGINEER	
DEPTH OF CONDUIT	< 14'	20'	
	14' - 16'	25'	
	17' - 20'	30'	
	21' - 23'	35'	
	> 23'	40'	

### SUBSECTION 5.01.04 | SEPERATION OF WATER AND WASTEWATER LINES

All water lines and wastewater lines shall be separated ten (10) foot horizontally and per TCEQ Rules and Regulations. Refer to the following for additional requirements:

- [CHAPTER 290, PUBLIC DRINKING WATER SUBCHAPTER D: RULES AND REGULATIONS FOR PUBLIC WATER SYSTEMS, §290.38 - 290.47](#)
- [CHAPTER 217, DESIGN CRITERIA FOR DOMESTIC WASTEWATER SYSTEMS SUBCHAPTER C: CONVENTIONAL COLLECTION SYSTEMS, §217.51 - 217.70](#)

For separation between storm lines, a spacing of five (5) foot horizontal shall be maintained from outside dimension of storm pipe to the water or wastewater line.

### SUBSECTION 5.01.05 | WATER AND WASTEWATER LINES WITHIN TXDOT RIGHT-OF-WAY

Water and wastewater lines within or crossing a Texas Department of Transportation (TXDOT) right-of-way (ROW) shall meet the requirements of the TXDOT District Office and the TXDOT Utility Manual. Utility permits for lines within or crossing TXDOT rights-of-way shall be processed through the City's Engineering Department. TXDOT permit plan sets shall be 11-inch by 17-inch in size and signed and sealed by a licensed professional engineer with the State of Texas. Plan sets shall include all applicable TXDOT standard details and traffic control plans sheets to construct the lines.

New proposed utility lines shall be outside of TXDOT ROW, on private property, within an easement.

### SUBSECTION 5.01.06 | BORING, JACKING, AND TUNNELING

All water and wastewater mains to be installed in steel casing under existing Texas Department of Transportation (TXDOT) and City maintained arterial roadways, railroads, and creeks and shall be installed by a method other than open cut, unless otherwise approved by the City Engineer. Casing pipe may also be required where deemed necessary by the City Engineer. All crossings, regardless of casing, of existing City maintained pavement shall be installed by a method other than open cut, unless otherwise approved by the City Engineer, all boring of water and wastewater lines shall be by dry bore methods. No wet bores will be allowed.

Steel casing thickness and diameter size shall be designed by the engineer of record for construction and maintenance of the carrier pipe per the requirements below. Raci patented casing spacers, or approved equal, shall be used. No bends and/or curves are permitted with casing pipes. The construction bore and receiving pit shall be located at a minimum distance of four (4) feet behind the back of curb. The engineer of record shall provide a distance greater than four (4) feet where there is no curb or barrier protection at the edge of pavement. Additional bore setback distances or shoring shall be required to maintain roadway integrity and the safety of construction





personnel. When bore and receiving pits are located on private property, permanent water and wastewater easements for the pits will be required for the installation and future maintenance of the line.

The engineer of record shall design the pipe casing for the following loading conditions and/or applicable combinations thereof:

- Cooper's E-80 Railway loading or AASHTO HS20 loading, as applicable.
- Earth loading with the height of fill above the casing as shown on the plans as existing or finish grade whichever is greater.
- All other applicable loading conditions, including loads applied during transportation and handling.
- Max casing deflection of ½-inch from the above loading conditions.

Engineer of records shall consider the location, size, and depth of bore and receiving pits relative to existing utilities when establishing the beginning and ending stations.

Manufacturers: Paint Manufacturers for pipe casing shall be 46-465 H.B. Tnemecol; Tnemec Inc. or approved equal.

### SUBSECTION 5.01.07 | CROSSINGS

#### SUBSECTION 5.01.07.01 | CITY ROADWAY CROSSINGS

All City roadway crossings shall be by dry bore. Open cut is by City Engineer written approval only, and shall require full panel concrete replacement at a minimum.

#### SUBSECTION 5.01.07.02 | CULVERT CROSSINGS

A steel encasement pipe shall be used to encase the carrier pipe with a minimum vertical clearance of two (2) feet from the bottom of the culvert and casing pipe. The encasement pipe shall be extended a minimum of five (5) feet from the outside edge of a box culvert or the outside diameter edge of the storm sewer for future maintenance of the carrier pipe. All culvert crossing shall be profiled.

#### SUBSECTION 5.01.07.03 | CREEK CROSSINGS

Water and wastewater lines at creek crossing shall be design to go under the flowline of the crossing. The lines shall be in steel encasement pipe with a minimum vertical clearance of four (4) feet from the encasement pipe and the flowline of the creek to protect from future creek undercutting. The encasement pipe shall be extended to the creek's erosion hazard set back line for future maintenance of the carrier pipe. Where an erosion hazard set back does not exist due to a shallow creek the encasement pipe shall extend 15-feet on either side of the main channel of the creek. All creek crossings shall be profiled and shall show the erosion hazard set back line along with the projected 4(H):1(V) sloping line and 15-foot buffer from the intersecting point of the ground. Aerial crossing of water lines is not allowed.

Aerial crossings for wastewater lines may be used only when all other alternatives have been evaluated and determined not to be feasible. Aerial crossings of wastewater lines require approval of the City Engineer. If an aerial crossing is to be installed, reference additional requirements in the Wastewater System Section. No syphons are allowed.

#### SUBSECTION 5.01.07.04 | TXDOT HIGHWAY CROSSING

A steel encasement pipe shall be used to encase the carrier pipe at all TXDOT highway crossings. The crossing shall be at 90-degree (*perpendicular*) to the highway. All boring of water and wastewater lines shall be by dry bore methods. No wet bores will be allowed unless approved in writing by the TXDOT District Office.

#### SUBSECTION 5.01.07.05 | RAILROAD CROSSINGS

Prior to the design of any railroad crossing, the engineer of record shall contact the railroad and the appropriate regulatory agency to determine if there are any special design and/or construction requirements and shall copy the City Engineer on all correspondence with each regulatory agency and approved permits.

### SECTION 5.02 | WATER SYSTEM



### SUBSECTION 5.02.01 | GENERAL

All facilities shall be sufficient size to provide adequate capacity for ultimate development as called out in the latest copy of the *Water Master Plan*. The water mains shall be sized to meet the maximum instant domestic requirements plus an appropriate allowance for fire protection water. The design criteria for water demand shall be submitted to the City with the plans and specifications. The City reserves the right to require larger water mains than required for the proposed development in order to provide capacities for areas outside the development. The developer will be responsible to construct water mains adjacent to his property in accordance with the latest *Water Master Plan* or as required by the City Engineer.

### SUBSECTION 5.02.02 | CONNECTIONS TO EXISTING DISTRIBUTION SYSTEM

Preliminary discussions concerning take-off points in the water system should be conducted with the City of Rockwall Engineering Department or its designated representative prior to finalizing the preliminary designs of the water system, which will serve the development. Connections to the City's existing water system will be allowed only at locations where sufficient quantity and pressures are available to meet the projected requirements of the development. In general, the connections to the existing water system shall be made in such a manner to keep "shut-downs" to a minimum. Preference should be given to a tapping valve connection.

In a proposed development where City water is not adjacent to the property but is accessible, the developer shall provide, at their expense, a minimum of eight (8) inch water main, an off-site water main of sufficient size to serve his development, or as shown on the City's *Water Master Plan*, whichever is larger. The City can participate (*if funds are available*) or collect pro-rata for the oversize of the required line. The City participation must be approved by the City Council. The proposed development may require a loop into the existing water system in order to provide adequate water pressure. The loop will be at the developer's expense. All water main shall be extended to the property lines for future connections.

In general, the City will not approve a development, which cannot be served by extensions to the City water system. Some areas in the City are served by water supply corporations. The *Developer* shall contact these water supply corporations for notification of future development. The *Developer* shall still be responsible to construct water facilities that meet City requirements and as shown on the City's *Water Master Plan*. The City will inspect the water facilities. All water facilities must pass North Texas Municipal Water District testing prior to acceptance of said facility.

Under unusual circumstances, the City may consider approval of a private water system, which will supply an adequate quantity of potable water to every lot in a residential development. Such systems must meet the approval of the City, the TCEQ, the State Board of Insurance and other appropriate regulatory agencies. In addition, an agreement between the City and the developer must be executed whereby the City may acquire the system at such time as it can be connected into the City's owned and operated distribution network. In all cases, the engineering drawings shall show the source of water for the development.

### SUBSECTION 5.02.03 | SIZING OF WATER MAINS

- (A) Water mains shall be sized to have maximum velocities of seven (7) feet per second for maximum daily demands and maximum velocities of ten (10) feet per second for combined maximum daily demand and fire flow demands.
- (B) [TABLE 5.2](#) provides the water demand for residential land uses and non-residential land uses and shall apply for any development where the lot layout has not been finalized. Land uses not listed shall be classified by the land use they most nearly resemble in [TABLE 5.2](#) or calculated by the engineer in accordance with the anticipated use. The engineer shall submit the maximum daily demand and the maximum hourly demand to the City Engineer for review and approval. The City reserves the right to assign a higher water usage rate, population per unit, and/or units per acre to be used for developments anticipated to generate higher than typical usage rates.
- (C) The engineer shall sufficiently size all water mains to provide adequate capacity for ultimate development as called out in the latest copy of the City's *Water Master Plan*. For all developments, re-developments, and any type of facility tying into the City's water distribution system, the following guidelines shall be used:
  - (1) The engineer shall obtain the available record drawings. When record drawings are not available, field investigations and verifications shall be required prior to construction.
  - (2) The standard water main sizes that shall be used are noted in the [TABLE 5.3](#).
  - (3) The minimum water main size to serve residential areas shall be eight (8) inches in diameter



- (4) The minimum water main size serving commercial, business, industrial, etc. shall be eight (8) inches.
- (5) Fire Flow Demands for all districts shall be calculated with a minimum residual pressure of 20 PSI under combined fire and domestic (*Maximum Daily Demand*) water flow conditions and/or the latest requirement by the TCEQ. The developer shall provide facilities sufficient for fire flows in accordance with the minimum criteria set for by the City’s Fire Marshal Office.
- (6) Mains are to be sized to ensure less than one (1) foot of head loss per 1,000-feet of water main using a Hazen Williams coefficient of C = 110 for the *Maximum Hourly Demand* flow rates within the subdivision internal distribution system.
- (7) Mains shall be sized to provide service to adjacent properties.

**TABLE 5.2: WATER DEMAND RATES**

LAND USE	UNITS PER ACRE	POPULATION PER UNIT	MAX DAY PER CAPITA (GPCD)	MAX HOUR PER CAPITA (GPCD)	MAX DAY PER ACRE (GPAD)	MAX HOUR PER ACRE (GPAD)
<b>RESIDENTIAL</b>						
SINGLE FAMILY - LOW DENSITY	3.5	2.87	350	700		
SINGLE FAMILY - MEDIUM DENSITY	8.0	2.87	350	700		
SINGLE FAMILY - HIGH DENSITY	18.0	2.87	350	700		
TOWNHOME	4.0	2.50	350	700		
MULTI FAMILY	12.0-16.0	2.00	350	700		
MOBILE HOME PARK	8.7	2.87	200	360		
<b>NON-RESIDENTIAL</b>						
MIXED USE / LIVE WORK / DOWNTOWN			350	700		
COMMERCIAL RETAIL / BUSINESS CENTER					1,500	3,000
PUBLIC / QUASI-PUBLIC					1,500	2,000
COMMERCIAL INDUSTRIAL					2,000	3,000
SPECIAL COMMERCIAL CORRIDOR / TECHNOLOGY EMPLOYMENT CENTER					3,000	3,900
LIGHT MANUFACTURING <sup>1</sup>					2,000	3,000
HEAVY MANUFACTURING <sup>1</sup>					2,500	3,000
SCHOOLS (ELEMENTARY)			39 PER STUDENT	52 PER STUDENT		
SCHOOLS (MIDDLE / HIGH SCHOOLS / COLLEGES)					1,500	2,000
HOSPITALS			720 GPD PER BED	864 GPD PER BED		
NURSING HOMES / ASSISTED LIVING			240 GPD PER BED	288 GPD PER BED		
RESTAURANTS					1,500	3,000
PARKS AND OPEN SPACE					1,500	1,500
GOLF COURSE <sup>2</sup>					1,000	1,000

**NOTES:**

<sup>1</sup>: ENGINEER SHALL PROVIDE THE MAXIMUM DAILY DEMAND AND MAXIMUM HOURLY DEMAND FLOWS AND/OR THE NUMBER AND SIZE OF WATER METERS PROPOSED FOR THE PARTICULAR LAND USE FOR REVIEW BY THE CITY.  
<sup>2</sup>: ENGINEER SHALL PROVIDE THE NUMBER AND SIZE OF WATER AND IRRIGATION METERS PROPOSED FOR THE GOLF COURSE FOR REVIEW BY THE CITY.



**TABLE 5.3: STANDARD WATER MAIN SIZES**

8-Inch	10-Inch	12-Inch	14-Inch	18-Inch
20-Inch	24-Inch	30-Inch	36-Inch	48-Inch
48-Inch	54-Inch	60-Inch	66-Inch	72-Inch

**SUBSECTION 5.02.04 | WATER MAINS LOCATION/ALIGNMENT**

Water pipelines shall be located in the parkways between the back of the curb and the street right-of-way. The location shall be six (6) feet from the back of curb on the north side of east-west streets and on the west side of north-south streets. When horizontal curvature is used the minimum radius of curvature shall be equal to that recommended by the pipe manufacturer. No water main less than ten (10) inches shall be located nearer than five (5) feet from any tree. No water main ten (10) inches or greater shall be located nearer than ten (10) feet from any tree.

Water mains should not be designed to pass through single-family lots or between single-family lots unless fully within a HOA owned and maintained lot.

A blue EMS Locator Pad will be located as shown in the *Standard Drawings*. Water mains shall have blue EMS locator pads at every 250-feet, change in direction, valve, curb stop, and service connection to the main water main.

**SUBSECTION 5.02.05 | DEPTH OF COVER**

The minimum depth of cover for water mains are indicated in [TABLE 5.4](#).

**TABLE 5.4: DEPTH OF COVER TO TOP OF PIPE**

PIPE SIZE	MINIMUM DEPTH OF COVER
6-INCH THROUGH 10-INCH	4.0- FEET
12-INCH THROUGH 18-INCH	5.0- FEET
20-INCH OR LARGER	6.0- FEET

The engineer shall consider the ultimate roadway elevations in determining the depth of cover. Additional depth of cover shall be required for future development and as directed by the City Engineer. Depths of cover greater than eight (8) feet shall be approved by the City Engineer. Water mains should be installed as close to the minimum as possible. If a proposed development's proposed grading changes the depth of an existing water main, the water main may be required to be relocated.

**SUBSECTION 5.02.06 | PIPE MATERIAL AND EMBEDMENT**

Water mains shall be PVC pipe conforming to the *Standard Specifications for Construction*. In general, the water pipelines shall be AWWA C900-16 PVC Pipe (*blue in color*) for all sizes, DR 14 (PC 305) for pipeline sizes 12-inch and smaller, and DR 18 (PC 235) for 14-inch and larger water pipelines. All pipes shall be installed in embedment material as shown on the *Standard Drawings* and in conformance with the *Standard Specifications for Construction*.

**SUBSECTION 5.02.07 | VALVES**

Valves shall be installed on the main to isolate pipe at a minimum of every fire hydrant and on both sides of all public roadways. All gate valves shall comply with the approved list or an approved equal with resilient seat only and shall conform to and shall be installed according to the *Standard Specifications for Construction*.

- (A) Valves shall be placed in straight run sections at spacing no greater than 500-feet.
- (B) All valve boxes shall be encased in a concrete pad that shall be minimum 12-inches by 12-inches by six (6) inches and reinforced with No. 3 steel bars. Valves larger than eight (8) inches may require larger concrete pads.
- (C) Valve extensions shall be 316 stainless-steel.
- (D) Unless otherwise requested by the developer and approved by the City, valves shall be located in the northwest quadrant of the street intersection.



- (E) Valves shall be placed at or near the ends of mains in such a manner that a shutdown can be made for a future main extension without causing loss of service on the existing main. A minimum of 20-feet of main shall be installed past the valve and mechanical pipe thrust restraints shall be used to anchor it.
- (F) Valves should not be placed in vehicle parking spaces.
- (G) Where fire lines are connected to the water main, valves shall be installed on one side of the connection of the main to provide the ability to isolate the main line and continue to provide water to the fire line. The fire line shall be provided with a valve at the connection with the main line.
- (H) Valve boxes shall be provided for buried valves. They shall be three (3) piece screw-type cast iron boxes of the extension type. The three pieces shall consist of the top section, bottom section, and cover.
- (I) Two-inch square nuts that would be over four (4) feet deep shall have stainless-steel valve stem extensions. In these cases, the two (2) inch square valve operating nut shall be no greater than two (2) feet from the finish grade. Valve box extensions may be cast iron or C-900 PVC.
- (J) Additional valves may be required by the City Engineer. Additional valves may be required for fire support or isolation purposes.

#### SUBSECTION 5.02.07.01 | GATE VALVES

Valves 12-inches and under shall be Resilient Wedge Gate Valves (RWGV). Valves are required to have 316 stainless-steel hardware. Gate valves shall be located outside the paved streets and shall be six (6) feet from back of curb of the intersecting street. In general, gate valves shall be located at street intersections (*except for fire hydrant leads*).

#### SUBSECTION 5.02.07.02 | BUTTERFLY VALVES

Valves greater than 12-inches shall be flanged butterfly type spaced at a maximum of 1,000-foot intervals. All valves shall have horizontal mounted actuators with a manhole for access to the actuators.

#### SUBSECTION 5.02.07.03 | AIR RELEASE, AIR/VACUUM, AND COMBINATION AIR VALVES

- (A) Air release valves, air/vacuum, and combination air valves shall be required on 16-inch and larger water mains and as necessary for proper system operation. There are three (3) primary functions of the valves that the engineer shall consider as follows:
  - (1) To vent large volumes of air during filling of the line;
  - (2) To allow air into the pipe during emptying for maintenance and/or repairs; and,
  - (3) To vent small volumes of air that come out of solution during service.
- (B) Typically, these are installed at high points where the pipeline has a vertical change in gradient. Additional installation locations may be required by the City Engineer.
- (C) A fire hydrant shall be required at high points on 12-inch water mains for air relief and flushing maintenance operations. When a fire hydrant cannot be used, an air release valve may be approved by the City Engineer.

#### SUBSECTION 5.02.08 | FITTINGS

Mega-lugs or approved equal shall be installed. No compaction fittings allowed. Fittings shall be ductile iron in accordance with AWWA C110 or AWWA C153. All buried metal shall be wrapped in polyethylene tube wrap.

#### SUBSECTION 5.02.09 | CONNECTION TO EXISTING WATER MAINS

##### SUBSECTION 5.02.09.01 | TAPPING SLEEVES AND VALVES

- (A) Size on size tapping sleeves are not allowed. The largest allowable tapping sleeve shall be the main line size less one (1) standard pipe size (*Example: 16-inch by 12-inch, eight [8] inch by six [6] inch, etc.*). If a size on size connection is required, then a cut-in connection shall be used.
- (B) Connections to an existing line shall be made with full body stainless-steel tapping sleeve and valve. A resilient wedge gate valve shall be flanged to the tapping sleeve.



- (C) Age, material, or condition of existing main may prohibit the use of a tapping sleeve for connections. Older mains can have major failures when tapping is attempted.

#### SUBSECTION 5.02.09.02 | CUT-IN CONNECTION

When connecting to an existing main, it may be required to provide a cut-in connection with a tee and valve being installed into the existing main in lieu of a tapping sleeve and valve where there is not an existing main line valve between proposed water connection locations as directed by the City Engineer. A test shut down of the existing water main(s) shall be conducted by the Water Department. The requirement for a test shutdown may be waived with approvals of the City Engineer. Only the City's Water Department may perform a water shut down.

#### SUBSECTION 5.02.10 | DEAD-END MAINS

- (A) Dead-end mains shall be avoided and may only be considered when a looped or interconnected water main system is not available. The design of all water distribution systems should include the opportunity for future looping or interconnect of any approved or proposed dead-end line.
- (B) All dead-end lines shall only be installed upon approval from the City Engineer and at a maximum length of 150-feet regardless of main diameter or valve placement.
- (C) Dead-end non-residential water mains shall only have one fire hydrant or service without looping the water main.
- (D) Where dead-end mains are approved, a flush point at the end of the dead end main shall be provided.

#### SUBSECTION 5.02.11 | FIRE HYDRANTS

In general, fire hydrants shall be located at each street intersection and at intervals on the interior of each block.

(A) Residential and Duplex.

Residential and duplex areas shall have a fire hydrant at each street intersection and at a maximum of 400-foot intervals on the interior of each block. The City Fire Marshal may alter spacing requirements along roadways depending on subdivision layout.

- (B) Multi Family. Multi-Family areas shall have a fire hydrant at each street intersection and at a maximum of 400-foot intervals on the interior of each block and along fire lanes. The City Fire Marshal may alter spacing requirements along fire lanes depending on fire suppression systems being installed.

- (C) Commercial, Retail and Industrial. Commercial, retail and industrial areas shall have a fire hydrant at each street intersection and at a maximum of 400-foot intervals on the interior of each block and along fire lanes. The City Fire Marshal may alter spacing requirements along fire lanes depending on fire suppression systems being installed.

- (D) Rural Undeveloped Roadway. Water lines along roadways in rural areas that have not been developed, or development is sparse shall have fire hydrants installed a maximum of every 1,000-feet. Additional hydrants may be required by the City.

Fire hydrants shall be installed a minimum of three (3) feet and no greater than six (6) feet behind curb of a fire lane, driveway, access, and/or street as measured from the centerline of the fire hydrant to back of curb, edge of pavement, or fire lane. All fire hydrants shall have five (5) feet of clearance around, including but not limited to trees, shrubs, bollards, walls, signs, structures, and parking stall curbs.

The spacing of fire hydrants shall be measured along the street frontage or fire lanes. The City Fire Marshal and Engineering Department shall review all fire hydrant spacing. When a special condition exists due to land use, the Fire Marshal or City Engineer may require additional hydrants for fire protection. All existing fire flows and pressure tests shall be obtained from a private company (THE CITY DOES NOT PERFORM THIS TEST).

Fire hydrants shall comply with the approved list or an approved equal conforming to the requirements set forth in the *Standard Specifications for Construction*. All fire hydrants shall be installed with a six (6) inch gate valve on the hydrant lead. The installation shall be as set forth in the *Standard Specifications for Construction*. Fire hydrants shall be painted to meet the City's requirements for color code as set forth in the *Standard Specifications*. In general, the fire hydrant will be reflective silver with differing cap color, which corresponds to the size of hydrant feeder line, as detailed in *Approved Water Materials List* in the Appendix.



Fire hydrants shall be installed at the end of each dead-end line. Minimum lead size for a fire hydrant shall be eight (8) inches if the fire hydrant lead is 50-feet or longer. Fire Hydrant leads may not be longer than 150-feet. Fire hydrants are not to be powder coated. Fire hydrants nozzles are to be a minimum of 19-inches to a maximum of 28-inches above final grade.

Nozzle diameter shall be two hose nozzles measuring 2½-inches nominal inner diameter and one pumper nozzle measuring 4½-inches nominal inner diameter. All nozzles are to have *National Standard Hose Threads*. The operating nut and nozzle nuts shall be 1½-inch pentagon-point to flat size/shape.

- (A) Standard fire hydrant barrel shoe depth where ever practical shall be five (5) feet. The fire hydrant lead line shall be adjusted to meet the standard fire hydrant depth.
- (B) The connection to the main line shall include a flanged tee connected to a flange by mechanical joint gate valve. The mechanical joint shall be restrained so that the fire hydrant is anchored to the valve.
- (C) Specifications. Fire hydrants shall be three-way breakaway type no less than 5¼-inch size. Mechanical joint connection is required.

### SUBSECTION 5.02.12 | WATER SYSTEM CONNECTIONS

Service connections shall be in accordance with the designs shown on the *Standard Drawings*. The materials shall comply with approved list or approved equal and shall be installed in accordance with the *Standard Specifications for Construction*.

- (A) All service pipelines shall be constructed of SDR-9 (*Polytube*) having a minimum size of one (1) inch. All connections shall be compression type or approved equal.
- (B) Detector pads embedded in sand shall be installed above all service connections.
- (C) All meter boxes for residential properties shall be set between the sidewalk and the back of curb. If sidewalk is located on the back of curb, the water meter shall be set between sidewalk and edge of ROW. Meter box tops shall be set one-half (½) inch to 1½-inch above the curb, and an angle meter stop shall be set six (6) inches below the meter box top. Meter boxes shall have a one (1) inch wide slot from five (5) inches below the top of the box to the bottom of the box on the side facing the lot for service connection.
- (D) Any meter box installed in paving shall be traffic rated.
- (E) Water meters shall not be located within a driveway or drive approach unless is a traffic rated box and lid.
- (F) A domestic and/or irrigation service connection shall not be allowed on fire hydrant leads.
- (G) Installation of multiple meters per water service will not be allowed. Only one (1) meter per service will be allowed. *Bull Heading* of services and meters shall not be allowed except for special conditions and approved by City Engineer approval only.
- (H) Service saddle shall be double bronze flattened straps or stainless-steel double bolt wide straps (*no banded straps shall be allowed*) with brass body. Service saddle shall be per the approved material list. Minimum size tap shall be one (1) inch diameter.
- (I) Water meter sizes shall not be bigger than the service line size from the water main to the meter.
- (J) All meters two (2) inch and under shall be purchased from the City and will be at developer's/contractor's expense. All meters greater than two (2) inches must be approved by the City and shall be furnished and paid for by the developer/contractor.
- (K) Concrete meter vaults are required for meter sizes three (3) inches and larger, meters and vaults shall be provided by the contractor. Meter vaults shall be sealed on the outside of the vault to prevent water from draining into the vault. Meter vault and meter requirements are shown in the *Standard Drawing* section.
- (L) Bending of water service from main to meter should be avoided.
- (M) Residential Water Meters.
  - (1) In single family residential developments, the nearest edge of the water meter box shall be a minimum of six (6) inches behind the back of curb, and the water service shall be no more than 12-inches deep, covered with a meter box in place at grade. If sidewalk is on the back of curb, the nearest edge of the water meter box shall be a minimum of six (6) inches behind the back of sidewalk, and the water service shall be no more than 12-inches deep, covered with a meter box in place at grade. If no curb is present, the water meter shall be located at the right-of-way line, no more than 12-inches deep, covered with a meter box in place at grade. Along roadways without a curb, the water service line shall be constructed at a minimum of 24-inches below the ditch flowline. Meter boxes shall not be placed in the invert of a ditch.



- (2) For multi-family, condominium and townhouse developments installation of multiple meter boxes: may only be installed at approved locations. Each service box shall service one (1) lot/building. Installation of multiple meters per water service will not be allowed. Only one (1) meter per service will be allowed. All meters are to have a testable double check backflow device installed below grade at the meter.

(N) Non-Residential Water Meters.

- (1) Installation of non-residential three (3) inches and larger meters will include two (2) mainline valves, one (1) bypass valve with chain and lock, and bypass line, all located inside the vault. Clearances between fasteners on valves, strainers, and meters to interior surfaces shall provide adequate room for maintenance. All meters are to have a testable double check backflow device installed below grade at the meter.
- (2) Non-residential and multifamily water meters will be located within the right-of-way or within a water easement and clear of high traffic areas. Location within ROW shall match that of *Section 5.2.12.L*. All meters are to have a testable double check backflow device installed below grade at the meter.
- (3) Water meter vaults shall be sized according to the size of the water meter and to allow for a minimum of a 12-inch clear working area for maintenance and operation. Minimum water meter vault sizes are shown in the City of Rockwall *Standard Details*.
- (4) Non-residential domestic and irrigation meters shall have a testable double check backflow preventer installed below grade at the meter.

SUBSECTION 5.02.13 | ABANDONMENT OF WATER MAINS

- (A) The engineer is to note the limits and appropriate conditions for abandoning existing water mains that are being replaced. For lines being abandoned, the engineer should note and locate points of cut and plug at the junction with the line that remains in service.
- (B) The engineer shall make allowances to permit the existing and proposed mains to remain in service simultaneously thereby providing a means for transferring customer's services from the old main to the new main with minimum interruption. If the construction of a proposed main necessitates the abandoning of the existing main prior to the new main's placement into service, then provisions for a temporary water main with services and fire flow must be addressed with the design.
- (C) Abandoned water lines to remain in place shall be cut and plugged and all void spaces within the abandoned line shall be filled with grout, flowable fill, or an expandable permanent foam product. Valves to be abandoned in place shall have any extensions and the valve box removed and shall be capped in concrete.
- (D) Existing fire hydrants and valves located on mains/hydrant leads being abandoned are to be removed and delivered to the Water Department.

SECTION 5.03 | WASTEWATER SYSTEM

SUBSECTION 5.03.01 | GENERAL

All facilities shall be sufficient size to provide adequate capacity for the ultimate development. The wastewater lines shall be sized to meet the peak-day wet weather flow plus an appropriate allowance for infiltration of storm water. The minimum wastewater main size (*other than service lines*) for all developments shall be eight (8) inches in diameter. The design criteria and calculation shall be submitted to the City with the plans and specifications. The City reserves the right to require a wastewater main of a larger size than that required by the development in order to provide capacities for areas outside of the development. Wastewater systems shall be designed so that all wastewater mains will be gravity flow. The use of a wastewater lift station can only be allowed with written approval by the City Engineer.

Connections to substandard mains and manholes shall not be allowed. Substandard mains and manholes shall be determined by the City Engineer based on criteria including, but not limited to: size, material, condition, flow rate, capacity, etc. Offsite improvements will be provided by the development for adequate wastewater service to the site.

All wastewater mains shall be installed at a depth sufficient to permit all water mains to be above the wastewater when the water main has a minimum cover of four (4) feet. In such cases where water mains either cross under, over within two (2) feet, or otherwise come





within ten (10) feet of a wastewater main, the wastewater main shall be PVC pressure pipe with a minimum working pressure class of 150 PSI or encased in concrete. Other conditions may have additional conditions per TCEQ.

### SUBSECTION 5.03.02 | OWNERSHIP AND MAINTENANCE

#### SUBSECTION 5.03.02.01 | OWNERSHIP

Ownership of wastewater systems shall conform to the following:

- (A) Wastewater mains within right-of-way or easements shall be owned by the City. This shall include the manholes and cleanouts on those lines.
- (B) Wastewater service laterals shall be owned by the property being serviced, from the wastewater main connection to the structure being serviced. This includes any and all manholes and cleanouts on the service lateral.

#### SUBSECTION 5.03.02.02 | MAINTENANCE

Maintenance of wastewater system shall conform to the following:

- (A) Wastewater mains within right-of-way or easements shall be maintained by the City. This shall include the manholes, pipe, cleanouts, etc. on those lines.
- (B) Wastewater service lateral shall be maintained by the property owner being served from the structure to the main

### SUBSECTION 5.03.03 | CONNECTIONS TO EXISTING WASTEWATER COLLECTION SYSTEM

Preliminary discussion concerning entrance points in the wastewater system should be conducted with the City of Rockwall Engineering Department or its designated representative prior to finalizing the preliminary designs of the collection system to serve the development. In a proposed development where City wastewater facilities are not adjacent to the property but are accessible, the developer shall provide, at his expense, an off-site wastewater interceptor of sufficient size to serve his development and the contributing service area (*using fully developed flows*), or as shown on the City's *Wastewater Master Plan*, whichever is larger. Developers can request a pro-rata agreement for wastewater over-size above ten (10) inch to be executed with the City, where the City collects a pro-rated amount as other developments connect to the system. This money would be distributed back to the developer that constructed the over-sized system. The pro-rata agreement requires approval by City Council.

*Connections to Existing Wastewater Mains.* When connecting a six (6) inch or larger new line to an existing wastewater main the engineer shall provide a new manhole at the point of connection. A six (6) inch service serving a single-family residential lot may use standard residential tap with City Engineer approval. Prior to connecting to the existing line, the new manhole and upstream pipe segment shall pass inspection by the City's Engineering Department or designated representative. Connections in residential locations shall be completed after the preliminary inspection of the main has been performed by the Engineering Department and approval is granted.

In general, the City will not approve a development which cannot be served by extensions to the City's wastewater collection system unless the development has received an approved variance granted by City Council. Pump and haul will not be allowed as a wastewater collection system under any circumstances unless it is for temporary use while the extensions to the City's wastewater collection system are complete.

### SUBSECTION 5.03.04 | DESIGN FLOW

All wastewater collection systems shall be designed in accordance with the current City's *Wastewater Master Plan*.

Where possible, all collection systems will be laid out so that all lines will be gravity flow unless approved by the City Engineer.

All wastewater collection systems must be designed to convey the peak wet weather flow from the entire service area including offsite areas through the system. The basin delineation shall be provided by using the latest LIDAR and surveyed contours. Contours shall be provided on two (2) foot or less intervals.

Flow calculations must include the specifics of the average daily flows, peak factor (*ratio of peak to average flows*) and the allowance for inflow and infiltration.

**SUBSECTION 5.03.05 | SIZING WASTEWATER COLLECTION MAINS**

**SUBSECTION 5.03.05.01 | GENERAL**

- (A) The engineer shall reference the *Wastewater Master Plan* to determine the size of wastewater mains required in order to serve the development. For all developments or re-developments that propose a change in existing land use (*change in density*) that does not conform to the City’s current *Wastewater System Master Plan* a Wastewater System Capacity Study shall be performed. This shall be done as per [SUBSECTION 5.01.01, SYSTEM CAPACITY STUDIES](#).
- (B) The standard wastewater pipe sizes that shall be used are noted in the [TABLE 5.5](#).

**TABLE 5.5: STANDARD WASTEWATER COLLECTION SYSTEM PIPE SIZES**

8-Inch	10-Inch	12-Inch	15-Inch	18-Inch
21-Inch	24-Inch	27-Inch	30-Inch	33-Inch
36-Inch	39-Inch	42-Inch	48-Inch	54-Inch
60-Inch				

**SUBSECTION 5.03.05.02 | AVERAGE DAILY FLOW**

- (A) [TABLE 5.6](#) shall be used to calculate the average daily wastewater flow. The collection system shall be designed based on the peak flow calculations, plus an allowance for inflow and infiltration.
- (B) For replacement of existing sewer for additional capacity, wastewater flow data will be provided by the City Engineer and the City’s wastewater modeling consultant from data generated by the City’s *Wastewater Master Plan* computer model.
- (C) Wastewater mains with direct connections to service lines shall be designed to be no more than 70.00% full and interceptors shall be designed for 100.00% full.
- (D) [TABLE 5.6](#) summarizes the residential and non-residential land use wastewater usage rates. Land uses not listed shall be classified by the land use they most nearly resemble in [TABLE 5.6](#) or calculated by the engineer in accordance with the anticipated use. The engineer shall submit the average daily flow and peak flow calculations including off-site flows within the drainage basin to the City Engineer for review and approval. The City reserves the right to assign a higher wastewater usage rate and/or population per unit to be used for developments anticipated to generate higher than typical usage rates.


**TABLE 5.6: WASTEWATER PER CAPITA AND USAGE RATES**

LAND USE	UNITS PER ACRE	POPULATION PER UNIT	AVERAGE DAILY FLOW (GALLONS PER PERSON OR UNIT/DAY)	AVERAGE DAILY FLOW PER ACRE (GPAD)
<b>RESIDENTIAL</b>				
SINGLE FAMILY - LOW DENSITY	3.5	2.87	90	
SINGLE FAMILY - MEDIUM DENSITY	8.0	2.87	90	
SINGLE FAMILY - HIGH DENSITY	18.0	2.87	90	
TOWNHOME	4.0	2.50	90	
MULTI FAMILY	12.0-16.0	2.00	80	
MOBILE HOME PARK	8.7	2.87	150	
<b>NON-RESIDENTIAL</b>				
MIXED USE / LIVE WORK / DOWNTOWN				800
COMMERCIAL RETAIL / BUSINESS CENTER				800
PUBLIC / QUASI-PUBLIC				1,000
COMMERCIAL INDUSTRIAL				1,500
SPECIAL COMMERCIAL CORRIDOR / TECHNOLOGY EMPLOYMENT CENTER				1,200
LIGHT MANUFACTURING <sup>1</sup>				1,500
HEAVY MANUFACTURING <sup>1</sup>				3,000
SCHOOLS (ELEMENTARY)			30 PER STUDENT	
SCHOOLS (MIDDLE / HIGH SCHOOLS / COLLEGES)			30 PER STUDENT	
HOSPITALS			400 PER BED	
NURSING HOMES / ASSISTED LIVING			300 PER BED	
RESTAURANTS			50 PER SEAT	
HOTELS			200 PER ROOM	
PARKS AND OPEN SPACE				0
GOLF COURSE				100

**NOTES:**

<sup>1</sup>: USAGE RATES SUBJECT TO CHANGE. ENGINEER FOR THE PROPOSED DEVELOPMENT SHALL PROVIDE ESTIMATES OF THE AVERAGE DAY AND PEAK HOUR WASTEWATER FLOWS BASED ON THE EXPECTED RATES OF USE FOR THE PROPOSED DEVELOPMENT. CITY WILL REVIEW AND PROVIDE DETERMINATION OF ANY REQUIRED CHANGES.

**SUBSECTION 5.03.05.03 | PEAK FLOW FACTOR**

Peak flow factors are as follows:

- (A) For average daily flow less than 0.05 MGD – Peak Flow Factor = 5.
- (B) For average daily flow between 0.05 MGD and 1.0 MGD – Peak Flow Factor = 4.



(C) For average daily flow between 1.01 MGD and 2.0 MGD – Peak Flow Factor = 3.5.

(D) For average daily flow greater than 2.0 MGD – Peak Flow Factor = 3.

#### SUBSECTION 5.03.05.04 | INFLOW AND INFILTRATION

After determining the peak flow amount, the engineer shall add an average daily inflow and infiltration rate of 400 GPAD. The inflow and infiltration amount calculated shall be added to the peak flow calculated, with the resultant being the peak wet weather flow, the basis for design.

#### SUBSECTION 5.03.06 | WASTEWATER MAINS

Wastewater pipelines shall be located in the parkways between the back of the curb and the street right-of-way. The location shall be six (6) feet from the back of the curb on the south side of east-west streets and on the east side of north-south streets. A green EMS Locator Pad is to be installed at every manhole, cleanout, and service connection to the wastewater main. If a wastewater line is to be constructed greater than ten (10) feet in depth and services are required, then a parallel line is to be constructed at a depth shallower than ten (10) feet. The deeper line shall be six (6) feet from the back of curb in the pavement side and the shallower line with services shall be six (6) feet from the back of curb toward the right of way. Depending on depth and exact location of the main, additional easement width may be required. An alternative to a parallel line is a special service connection, by City Engineer approval only. Two (2) sanitary sewer mains shall be installed running parallel over one (1) another. No wastewater main less than ten (10) inches shall be located nearer than five (5) feet from any tree. No wastewater main ten (10) inches or greater shall be located nearer than ten (10) feet from any tree. Wastewater mains should not be designed to pass through single-family lots or between single-family lots.

#### SUBSECTION 5.03.06.01 | PIPE MATERIAL

Allowable for gravity wastewater mains shall be per [TABLE 5.7](#).

TABLE 5.7: PIPE MATERIALS FOR WASTEWATER GRAVITY MAINS

PIPE SIZE	MINIMUM DEPTH OF COVER
4-INCH THROUGH 15-INCH	Green PVC – SDR 35 (ASTM D3034) [Less 10-Foot Cover]
	Green PVC – SDR 26 (ASTM D3034) [10-Foot or More Cover]
18-INCH OR LARGER	Green PVC – PS 46 (ASTM F679) [Less 10-Foot Cover]
	Green PVC – PS 115 (ASTM F679) [10-Foot or More Cover]

Pipe shall have a minimum earth cover of four (4) feet. All pipes shall be installed in embedment material as shown on the *Standard Details* and in conformance for the *Standard Specification for Construction*. Any main with less than minimum cover shall be encased in concrete and is subject to approval by the City Engineer. Depth of cover greater than 20-feet must be approved by the City Engineer. All pipelines shall be tested for infiltration.

#### SUBSECTION 5.03.06.02 | MINIMUM GRADES

Wastewater lines should operate with velocities of flow sufficient to prevent excessive deposits of solid materials, otherwise objectionable clogging may result. The controlling velocity with regard to sediment deposition is near the bottom of the conduit and considerably less than the mean velocity flowing full of two and a half feet per second (2.5 FPS). [TABLE 5.8](#) indicates the minimum grades for wastewater pipe with a Manning's "n" = 0.013 and flowing at 2.4 FPS.



**TABLE 5.8: MINIMUM GRADES FOR WASTEWATER PIPELINES**

PIPE SIZE (INCHES)	SLOPE (n = 0.013) (FOOT/FOOT)
6	0.0050
8	0.0033
10	0.0025
12	0.0023
15	0.0023
18	0.0018
21	0.0015
24	0.0013
27	0.0011
30	0.0009
33	0.0008
36	0.0007
39	0.0006
42	0.0006
45	0.0005
48	0.0005
54	0.0004
60	0.0004
66	0.0004
72	0.0003
78	0.0003
84	0.0003
96	0.0002

**SUBSECTION 5.03.06.03 | CURVED SEWERS**

No vertical curves will be allowed. Horizontal curvature may be allowed by joint deflection or pipe flexure but not both. The Engineer must specify on the plans the method of deflection allowed and the allowable radius or joint deflection for each pipe size.

When pipe flexure is used, the minimum radius of curvature shall be equal to that recommended by the pipe manufacturer or  $300 \times D_0$ , where  $D_0$  is the average outside diameter of the pipe in inches, whichever is greater. The Engineer shall note on the plans that when using pipe flexure, all joints are to remain fully seated.

If a joint deflection will be used to provide horizontal curvature, the allowable deflection shall be five (5) degrees or 80.00% of the manufacturer's recommended maximum joint deflection, or 80.00% of the National Reference Standard maximum recommended joint reflection, whichever is less. When joint reflection is used, the Engineer must specify the size of mandrel used for reflection testing. The mandrel shall be sized to verify that the maximum joint deflection has not been exceeded.

Horizontal curves shall match change in street direction as near as possible.

**SUBSECTION 5.03.07 | WASTEWATER SERVICE LATERALS**

Wastewater service pipelines shall be laid to each lot. The service pipelines shall be plastic pipe having a minimum diameter of four (4) inches and shall extend to the property line. Wastewater service pipelines shall be located on the lower side of each lot and as approved on the final construction plans by the City. In general, a service pipeline shall serve only one (1) lot. Special wastewater service sizing may be required in some instances. Where water and wastewater pipelines pass within ten (10) feet of each other horizontally, the method of construction shall be specified in order to meet TCEQ criteria. No wastewater main less than ten (10) inches shall be located nearer than five feet (5') from any tree. No wastewater main 10-inches or greater shall be located nearer than ten (10) feet from any tree. Service lines cannot connect to wastewater mains that are over ten (10) feet deep unless a special service connection is approved by the City Engineer.

Service laterals shall have a minimum horizontal separation of ten (10) feet downstream from any water service.

Bends in services under roadway pavement should be avoided.



Retail and Commercial. Service lateral size shall be six (6) inch minimum at a two (2) percent minimum grade.

### SUBSECTION 5.03.08 | MANHOLES

In general, manholes shall be located at all intersections of wastewater pipelines, changes in grade, changes in alignment, non-single family residential service connections, and at distances not to exceed 500-feet. A manhole maybe required for a residential sewer service six (6) inch or larger. Manholes should not be installed in parking stalls, inverts within pavement, gutter lines, or sidewalk ramp flares.

All manholes will be hydrostatically or vacuum tested. For manholes that have an epoxy coating after constructed, a spark test will be required prior to acceptance. Manhole sizing shall be per [TABLE 5.9](#) with a 30-inch lid. If a manhole exceeds ten (10) feet in depth, increase the diameter by one (1) foot from the sizes given in [TABLE 5.9](#).

TABLE 5.9: MINIMUM MANHOLE SIZES

WASTEWATER MAIN SIZE	MINIMUM MANHOLE DIAMETER
6", 8" AND 10"	4.0 FOOT <sup>1</sup>
12", 15", 18", 21", 24" AND 27"	5.0 FOOT <sup>1</sup>
30" AND 36"	6.0 FOOT <sup>1</sup>

#### **NOTES:**

<sup>1</sup>: INTERNAL DROP MANHOLES SHALL BE 6.0-FEET MINIMUM.

### SUBSECTION 5.03.08.01 | INTERNAL DROP MANHOLES

Internal drop manholes shall be required when the inflow elevation is more than 18-inches above the outflow elevation. New internal drop manholes shall be constructed with inside drops with a six (6) foot minimum diameter. Depending on the depth of the drop manhole and inside clearances between drop bowl apparatus and the manhole, the City Engineer may increase the minimum diameter above six (6) feet. Drop manholes shall increase in diameter as necessary to accommodate the pipe for an internal drop connection as necessary to provide 48-inches of clear space for construction and maintenance operations. Within the manhole the inverts shall be sloped to maintain a smooth transition through the manhole connecting all inlets and outlets. Outside drop connections will not be allowed. Only one (1) internal drop is allowed per manhole.

### SUBSECTION 5.03.08.02 | CORROSION PROTECTION

All manholes shall have Raven Liner 405 epoxy coating, ConShield, or approved equal. ConShield must have terracotta color dye mixed in the precast and cast-in-place concrete. Where connections to existing manholes are made the contractor shall rehab manhole as necessary and install a 250-mil thick coating of Raven Liner 405 or approved equal. Manhole shall be replaced at the developer's/contractor's expense if it cannot be rehabilitated.

### SUBSECTION 5.03.08.03 | WATERTIGHT SEALED MANHOLES

All manholes shall be sealed if located in an area of storm water flow (*paving, creek, drain way, etc.*). When manholes are placed within the limits of the fully developed 100-year floodplain, watertight sealed manholes (*Type S*) shall be used to prevent the entrance of stormwater and properly vent manhole. Manholes installed in the floodplain shall be a minimum of 60-inch diameter with a concentric flat top that has a rim elevation two (2) feet above the limits of the fully developed 100-year floodplain. When allowed by the City Engineer, manholes may be below the 100-year floodplain but must be bolted and gasketed. Every third (3<sup>rd</sup>) manhole shall be vented two (2) feet above the fully developed 100-year floodplain elevation or four (4) feet above the adjacent ground line, whichever is higher. Manhole rim shall be a minimum of two (2) feet above ground line but not to exceed four (4) feet above ground line. The engineer shall obtain and provide the elevation of the fully developed 100-year floodplain. When manholes are installed within a floodplain or open space, a location indicator pole shall be installed on the manhole to help prevent damage and for City to easily locate.

### SUBSECTION 5.03.08.04 | INFLOW PREVENTION

In order to reduce the size of wastewater system main trunk lines and reduce the cost of wastewater treatment, efforts to reducing inflow and infiltration into the wastewater collection system shall be taken. All manholes (*public or private*) shall be fitted with inflow prevention. The inflow prevention shall conform to the measures called out in standard detail R-5031.



### SUBSECTION 5.03.09 | CLEANOUTS

Cleanouts shall be constructed on the end of all lines. The maximum distance between a manhole and an upstream cleanout is 250-feet. Cleanouts may be located at the end of the line only. Double clean outs shall be installed for non-residential services at the right-of-way line, property line, or easement line where a public line changes to a private service. Cleanouts shall conform to the *Standard Details* and the *Standard Specifications for Construction*.

### SUBSECTION 5.03.10 | TESTING

All wastewater lines shall be tested for infiltration in accordance with the procedures set forth in the *Standard Specifications for Construction*. In general, all wastewater pipes shall be installed so that the completed wastewater will have a maximum exfiltration of 150-gallons per inch of internal diameter, per mile of pipe, per 24-hours, where the maximum hydrostatic head at the centerline of the pipe does not exceed 25-feet. All wastewater pipes shall be inspected by photographic means (*video/camera*) after franchise utility installation but prior to final acceptance. The contractor shall furnish a DVD or flash drive to the Engineering Department Construction Inspector for review. Any sags, open joints, cracked pipes, etc. shall be repaired or removed by the contractor at the contractor's expense. A television survey will be performed as part of the final testing in the twentieth (20<sup>th</sup>) month of the maintenance period. The City's representative shall be present at all testing. All expenses for this work shall be the developer's responsibility.

### SUBSECTION 5.03.11 | ABANDONING EXISTING WASTEWATER MAINS AND MANHOLES

When an existing wastewater line is to be abandoned all services and laterals on the main to be abandoned shall connect back into the system. All existing wastewater mains that are to be abandoned shall be videotaped to determine the location of the services and laterals. A copy of the videos shall be given to the City Engineering Construction Inspector for review before the line is fully abandoned.

All abandoned wastewater and force main lines shall be cut and plugged and all void spaces within the abandoned line shall be filled with grout, flowable fill or an expandable permanent foam product.

Wastewater manholes shall be abandoned per *Standard Drawing No. 5170*.

### SUBSECTION 5.03.12 | CREEK CROSSINGS

Wastewater lines constructed under or over any flowing stream or semi-permanent body of water, such as a marsh or pond, shall be installed inside a separate watertight encasement pipe. Wastewater lines shall have manholes on each side of the crossing.

The engineer of record shall determine the type and limits of any special embedment, and specify the limits for specialized backfills to prevent soil erosion at the areas of trench backfill as approved by the City Engineer.

#### SUBSECTION 5.03.12.01 | AERIAL CREEK CROSSINGS

Aerial crossings for wastewater lines may be used only when all other alternatives have been evaluated and determine not to be feasible. Aerial crossings of wastewater lines require approval of the City Engineer.

Aerial crossing shall meet the following requirements:

- (A) The design of all piers, bents, restraints, abutments, steel casing, etc. for the aerial crossing shall be performed and signed and sealed by a Professional Structural Engineer licensed in the State of Texas.
- (B) The engineer of record shall use steel encasement pipe around all aerial carrier pipes. The carrier pipe shall be restrained or welded all around joints or be a monolithic pipe between a span section.
- (C) The pier spacing for the aerial crossing supports must maintain adequate grade, and span the 100-year floodway.
- (D) A span section must withstand the hydraulic forces applied by the occurrence of a 100-year flood including buoyancy. Both the aerial crossing encasement pipe and the supporting structure shall be capable of withstanding impacts from debris and water.
- (E) A scour analysis report prepared by a geotechnical professional engineer shall be submitted to the City Engineer for review.
- (F) A Hydrologic and Hydraulics Study of the aerial crossing shall be performed. The aerial crossing shall not increase the 100-year floodplain water surface elevations or velocities.
- (G) Geotechnical borings at the creek crossing and report shall be prepared by a Professional Geotechnical Engineer licensed in the State of Texas.



- (H) Wastewater lines shall have manholes on each side of the crossing.
- (I) The upstream bent/abutment section of the aerial crossing shall be designed with a minimum two (2) inch underdrain at the flowline of the embedment to collect infiltration that is travel within the upstream embedment of the aerial crossing. This shall day light at the aerial crossing current day slope to prevent erosion of the aerial crossing at the upstream end.
- (J) The aerial crossing shall be designed to extend to the erosion hazard setback line with piers and bents.

#### SUBSECTION 5.03.12.02 | INVERTED SIPHON

Inverted siphons at creek crossings for wastewater lines are not allowed.

### SECTION 5.04 | WASTEWATER LIFT STATIONS AND FORCE MAINS

#### SUBSECTION 5.04.01 | GENERAL

All lift station design plans and specifications shall be submitted to the City Engineer and TCEQ for review and approval prior to construction. Developments which increase the flow to existing lift stations will be subject to a pro-rata charge if sufficient capacity is available in the existing lift station or will be required to increase the capacity of the existing facility. Lift stations and force mains shall be designed and built for the upstream drainage area using a fully developed condition. This will include off-site areas if applicable. Developers are responsible for the construction of regional lift stations and force mains, per the *Wastewater Master Plan*. Developers can request a pro-rata agreement be executed with the City, where the City collects a pro-rated amount as other developments connect to the system. This money would be distributed back to the developer that constructed the oversized system. The pro-rata agreement requires approval by City Council.

The City will utilize an engineering consulting firm to assist City staff in the review of a report and plans for wastewater lift stations and force mains. The cost of this consultant review shall be borne by the developer, engineer, or property owner submitting the report and plans for wastewater lift stations and force mains. The City shall first obtain a cost estimate from the engineering consultant for the review at time of the initial engineering submittal. Before the review begins, the developer, engineer, or property owner submitting the report and plans for wastewater lift stations and force mains shall deposit with the City funds equal to the cost estimate. The City shall disburse the funds to the consulting engineer as the review progresses. Should the consultant fees exceed the initial estimate, the developer, engineer, or property owner submitting the report and plans for wastewater lift stations and force mains shall be informed of the shortage and a new estimate made by the consultant engineer to complete the review. Additional funds will then be deposited with the City by the developer, engineer or property owner submitting the report and plans for wastewater lift stations and force mains to cover the estimated shortfall before the review resumes. Any unused funds to be reimbursed to the developer, engineer or property owner submitting the report and plans for wastewater lift stations and force mains. If review process is performed by City staff, the City will submit a cost estimate for the review at time of the initial engineering submittal.

#### SUBSECTION 5.04.02 | DESIGN REPORT AND PLANS

A typed lift station and force main design report shall be prepared and signed and sealed by a register professional engineer licensed in the State of Texas.

#### SUBSECTION 5.04.02.01 | REPORT

The typed report shall include the following information at a minimum:

- (A) A brief summary of project scope that includes:
  - (1) General description of proposed development
  - (2) General explanation on circumstances that warrant a lift station including other options considered.
  - (3) Description of any potential phasing of lift station until sewer basin is built-out, if City Engineer approves lift station size less than fully developed conditions.
- (B) Influent hydraulic calculations showing:
  - (1) Area in acres of the sewer basin and the development.
  - (2) The area of each proposed use for the development and the ultimate projected use for the basin per City Future Land Use.
  - (3) The average design flow and the maximum peak flow for the basin and the development.





- (4) Elevation of the proposed lift station site.
- (5) The elevation of the proposed discharge point of the force main.
- (C) Wet well volume calculations
- (D) Force main size with proposed velocities in pipe.
- (E) Power outage records on electric provider letterhead for power outages in area for the past 24 months.
- (F) Opinion of probable costs for lift station, force main, and annual operating and maintenance costs.
- (G) Ground water levels in proposed site area.
- (H) Proposed system's effect on existing system's capacity.
- (I) Odor control methods shall be submitted to the City Engineer for review and approval. The potential odor determination must include the estimated flows immediately following construction and throughout a system's 50-year expected life cycle.

#### SUBSECTION 5.04.02.02 | PLANS

The plan or plans submitted shall contain the following minimum information:

- (A) Scale
- (B) North Arrow
- (C) Vicinity map
- (D) Delineation of the boundary of the proposed development and off-site areas of the sewer basin (service area) in which the development lies. Basin delineation shall be provided using NCTCOG, LIDAR or surveyed contours. Contours shall be provided on two (2') foot or less intervals. USGS topo is not permissible.
- (E) Area in acres of the development and of the sewer basin contributing to the lift station.
- (F) Proposed use or uses for the development and service area.
- (G) The proposed lift station location.
- (H) The proposed force main routing.
- (I) Delineation of the 100-year fully developed flood plain, FEMA 100-year flood plain and erosion hazard setbacks.
- (J) The location and size of the existing collection system at the tie-in point.
- (K) Property lines, easement lines, and right-of-way lines.

#### SUBSECTION 5.04.03 | SITE SELECTION

The following are the minimum criteria that shall be met for a lift station site:

- (A) The station should be located as remotely as possible from populated areas. The lift station site shall not be located within 150-feet of an existing or proposed residential dwelling and 100-feet from a residential lot.
- (B) The station shall be protected from the 100-year flood and shall be accessible during a 100-year flood. The elevation of the site shall be a minimum of one (1) foot above the fully developed 100-year flood plain.
- (C) The station site and its access shall be dedicated to the City as a wastewater easement. The fencing set back shall be five (5) feet from the easement line to allow for a landscape and drainage buffer.
- (D) The station site shall be located so it may serve as much of the entire sewer drainage basin as possible. This may require that the station be located off-site of the development. When a station serves a larger area than the proposed development, the developer can request a pro-rata agreement with the City to be reimbursed the cost of excess capacity as other developments connect to the system.

#### SUBSECTION 5.04.04 | SITE REQUIREMENTS

The lift station site shall conform to the requirements in these subsections and [FIGURE 5.1, TYPICAL LIFT STATION SITE LAYOUT](#).



#### SUBSECTION 5.04.04.01 | ACCESS

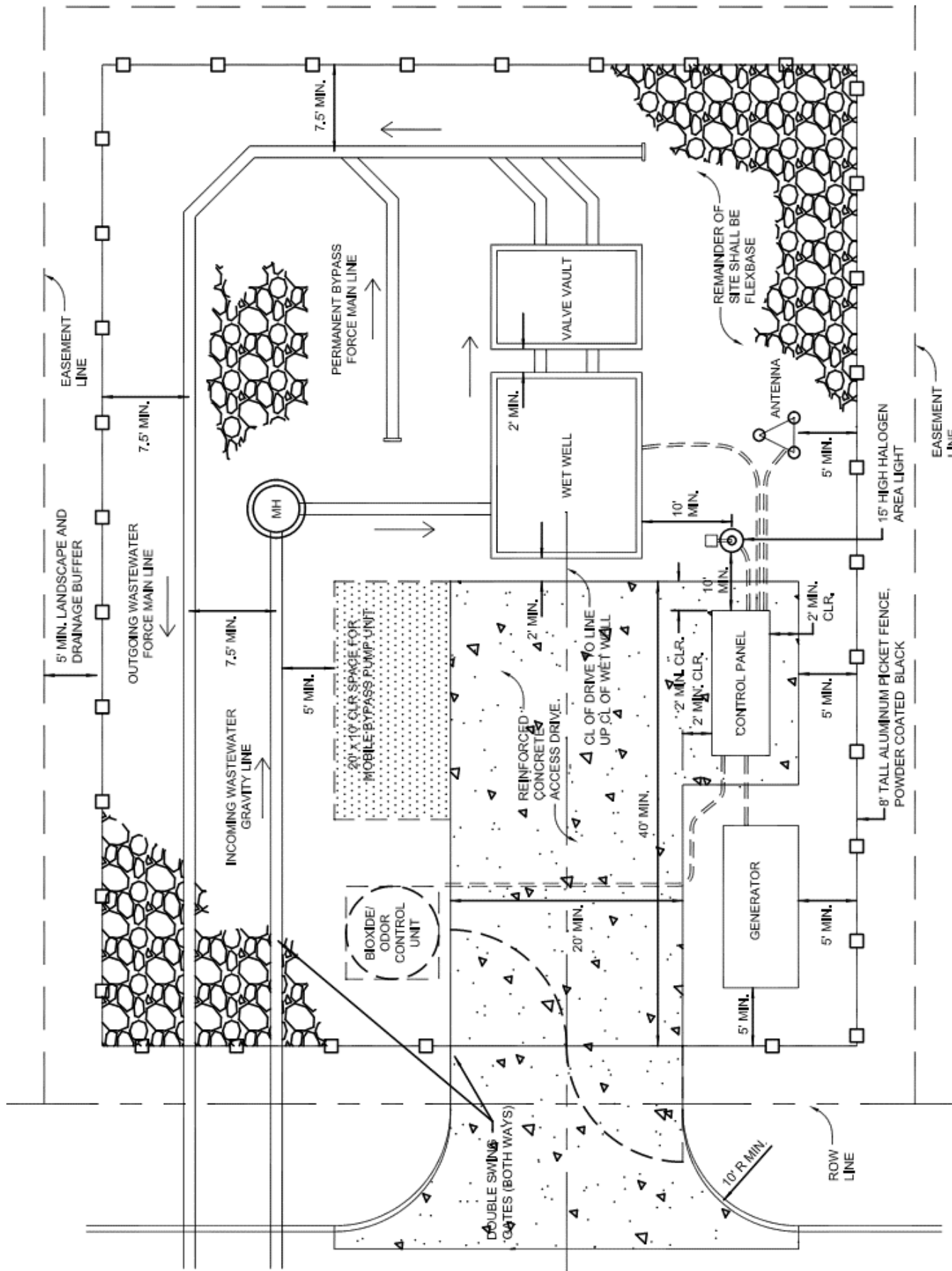
Access drive will be provided by a reinforced concrete pavement from a public street and/or dedicated access easement. Concrete shall be a minimum eight (8) inches thick, 3,600 PSI (6.5 sack/CY) with #4 bars at 18-inch OCEW reinforced concrete pavement with a minimum of 20-feet in width and 40-feet in length (*within fenced area of lift station*) to allow maintenance vehicles to park fully outside of the right-of-way.

When an access drive for the lift station connects to a City Thoroughfare or Texas Department of Transportation (TXDOT) designated highway a “T” shaped turnaround shall be provided with applicable turning radii. The alignment of the drive shall allow maintenance vehicles the ability to back up straight to the wet well.

Access shall be functional during a 100-year flood. All area within the lift station fencing and access drive shall be a minimum of one (1) foot above the water level caused by a 100-year fully developed floodplain.



FIGURE 5.1: TYPICAL LIFT STATION SITE LAYOUT





### SUBSECTION 5.04.04.02 | SECURITY

At a minimum, security of the lift station site shall be provided by an intruder-resistant fence (IRF) to restrict access by an unauthorized person(s). The IRF shall be placed around the perimeter of the site encompassing all interior structures and appurtenances shall maintain a minimum five (5) foot clearance from all lift station components and 7.50-foot minimum off of lift station piping.

The IRF shall be a minimum of eight (8) feet aluminum picket fence with a 20-foot-wide minimum double swing gate for access. All components shall be manufactured from aluminum extrusions having a minimum ultimate strength of 35,000 PSI, using 6005 T5 alloy. The fence, post and gates shall be powder coated black with a minimum cure film thickness of two (2) mils.

#### TECHNICAL DATA

Pickets. The hollow pickets shall pass through the rails and are to be attached using stainless-steel screws allowing the pickets to be always parallel to the terrain. Screws shall be on one (1) side of rail only. Pickets shall be one (1) inch square x 0.062-inch thick.

Horizontal Rails. Rails shall be C-Channels with ribbed reinforced side walls. Square holes shall be punched in the top of the rails to allow the pickets to pass through.

(A) Four (4) rails are required.

(B) *Heavy Industrial Rails* shall be 1 $\frac{5}{8}$ -inch by 1 $\frac{5}{8}$ -inch with a side thickness of 0.100-inch, top wall thickness 0.070-inch and bottom wall thickness of 0.062-inch, which snaps into the top allowing all screws to be enclosed inside the rail.

Posts. Posts shall be hollow square extrusion with holes pre-punched to allow the rails from the fence sections to slide into them. All posts shall include aluminum post caps. Posts can be placed no more than 6 feet apart.

(A) Line Posts and End Posts are three (3) inch square by 0.125-inch thick

(B) Gate Posts are four (4) inch square x 0.125-inch thick weighing nine (9) pounds per foot

Gates. Gates shall be fabricated with two (2) inch or 2 $\frac{1}{2}$ -inch square ends, 1 $\frac{5}{8}$ -inch by 1 $\frac{5}{8}$ -inch rails and one (1) inch square pickets. The gate shall be a double swing gate. Gate shall match appearance of fence panel. The gate shall have a double rail that allows for hidden fasteners and no exposed cavities under the rail. Gate shall be designed and manufactured by the fence manufacturer.

(A) Each gate shall have a hasp for chain locking welded to the frame as detailed in the construction plans.

(B) Gates shall be designed and manufactured by the fence manufacturer.

(C) Assembled section shall be able to support 500-pounds of vertical load at the mid-point of any horizontal frame rail.

(D) Swing gates shall include cane-bolts for each gate panel. The cane-boll shall have a stop to hold it in the up position for operating the gate.

(E) Hinges shall have minimum  $\frac{3}{8}$ -inch stainless-steel pins.

Post Installation. The post shall be set 36-inch in the concrete footing. The gate post shall set a minimum of 48-inch into the concrete footing.

There should be a minimum of a five (5) foot landscape and drainage buffer from the easement line to the lift station fencing. The five (5) foot buffer shall have Chinese Variegated Privet (*or similar vegetation as approved by the Director of Parks and Recreation*) place within the buffer to screen the lift station site.

### SUBSECTION 5.04.04.03 | SITE INTERIOR

Interior of the site that is not part of the access drive shall be a minimum six (6) inches thick flex base. Site shall be graded to drain away from the station to prevent storm water inflow or infiltration into the wet well, valve vault and manholes. The wet well and valve vault top elevation shall be a minimum of 12-inches higher than interior concrete and flex base.



Control panel shall have a two (2) foot minimum clear reinforced concrete working area away from face, sides and back of cabinet. Electrical and instrumentation panels shall be located where they do not obstruct vehicle access to the wet well or the dry well. They shall be placed at an elevation so that they are easily accessible.

A 15-foot high halogen or LED area light with photometric cell on an aluminum pole shall be placed within ten (10) feet of wet well and control panel without obstructing daily operations.

### SUBSECTION 5.04.05 | WET WELL AND VALVE VAULT DESIGN

#### SUBSECTION 5.04.05.01 | WET WELL DESIGN

Wet well shall be cast in place or pre-cast watertight and gas tight walls with watertight joint meeting ASTM C478-90. Steel, HDPE and RCP are not acceptable materials. The tops may be pre-cast with the hatches built in. All wall penetrations through the wet well wall shall be gas tight. The wet well shall be hydrostatically tested to the top of the wet well for 48-hours prior to putting the lift station into service. Only losses due to evaporation will be tolerated.

Additional design requirements are as follows:

(A) Orientation.

- (1) Orientation shall consider the routing of incoming sewer and force main for ease of maintenance and to minimize effluent turbulence.
- (2) Orientation shall allow a five (5) ton vehicle to pull in forwards or backwards directly to the wet well or the dry well.
- (3) All influent gravity mains discharging into the wet well shall be located so that the invert/flowline is above the "on" setting liquid level of the pumps.

(B) Level Sensors.

- (1) Level control system shall use a pressure transducer with built in surge protection for pump operation with Off and High-Level Floats as back-up in case transducer fails.
- (2) Sensors shall be provided for "All Pumps Off," "Lead Pump On," "Lag Pump On," and "High Level Alarm" levels as well as additional "Lag-Lag Pump On" for lift stations with more than two pumps.
- (3) Level Sensors shall be placed in the wet well.

(C) Wet Well and Valve Vault Separation.

- (1) Wet wells and valve vaults shall be separated by a minimum of two (2) feet.

(D) Liner and Coatings.

- (1) Wet wells shall have a minimum of ten (10) percent sloped bottoms to the pump intakes and shall have a smooth finish to avoid excess sludge deposits.
- (2) Wet wells shall be ConShield, Raven Lining or approved equal to protect against hydrogen sulfide gases.
- (3) Wet wells and valve vaults shall have inflow protection as called out in Standard detail R-5031.

(E) Hatches.

- (1) The wet well shall have a lockable odor suppressing aluminum door with an aluminum frame and safety grate. The minimum opening size shall be four (4) feet by six (6) feet with two (2) doors large enough to adequately maintain the wet well.
- (2) All hatches shall have accommodations for locking above grade with 3/8-inch shaft padlocks provided by the City.

(F) Ventilation.

- (1) The design of a wet well must reduce odor potential in a populated area or as directed by the City Engineer.
- (2) Passive ventilation structures shall be provided and must include screening to prevent the entry of birds and insects to the wet well. An air vent pipe shall have a minimum diameter of four (4) inches with outlet located one (1) foot above wet well top.
- (3) Continuous mechanical ventilation structures shall be provided with ventilation equipment providing a minimum capacity of 12 air exchanges per hour and be constructed of corrosion resistant material.

(G) Cable Strain Relief. A stainless-steel cable holder shall be provided for all cables in the wet well for cable strain relief purposes.



### SUBSECTION 5.04.05.02 | WET WELL VOLUME

- (A) Wet well volume for a submersible pump station is the volume contained above the top of the motor, or as specified by the pump manufacturer.
- (B) High level alarm elevation shall be a minimum of 60-inches below the top of the wet well or 48-inches below the flowline elevation of the lowest service tap, whichever elevation is lower.
- (1) Alarm shall be sent when both pumps are running on a duplex station or when the level is six (6) inches to 12-inches over all pumps running. The City Engineer shall approve all situations and levels that need to trigger an alarm.
  - (2) Wet well volume shall be calculated by [EQUATION 5.1](#):

### EQUATION 5.1: WET WELL VOLUME

$$V = \frac{TQ}{4(7.48)}$$

#### WHERE

V = ACTIVE VOLUME, (CUBIC FEET)

Q = PUMP CAPACITY, (GALLONS PER MINUTE)

T = CYCLE TIME, (MINUTES)

7.48 = CONVERSION FACTOR, (GALLONS PER CUBIC FOOT)

- (C) Pump cycle time, based on Peak Flow, must equal or exceed the criteria shown in [TABLE 5.10](#).

### TABLE 5.10: MINIMUM PUMP CYCLE TIME

PUMP HORSEPOWER	MINIMUM CYCLE TIMES
< 50	6 MINUTES
50-100	10 MINUTES
> 100	15 MINUTES

- (D) The operation cycle "T" shall not be less than ten (10) minutes for average flow and not more than 60-minutes for minimum flow conditions. The operation cycle time must exceed the manufacturer's requirements.

### SUBSECTION 5.04.05.03 | VALVE VAULT

- (A) Valve vaults shall have sloped bottoms towards a floor drain to remove liquid build up. The floor drain line from the valve vault connecting to the wet well must prevent gas and liquids from entering valve vault.
- (B) The valve vault shall have a lockable aluminum door with an aluminum frame. The minimum opening size shall be two (2) feet by three (3) feet or large enough to adequately maintain the valve vault.

### SUBSECTION 5.04.06 | PUMPS, LIFT STATION PIPING, AND VALVES

#### SUBSECTION 5.04.06.01 | PUMPS

- (A) Stations shall contain a minimum of two (2) pumps and shall be capable of handling peak flows with one (1) pump out of service.
- (B) All pumps shall be explosion proof, non-clog, submersible type capable of passing a 2½-inch diameter sphere or greater. Vortex impellers shall be used to prevent clogging.
- (C) Pumps shall be sized to operate at optimum efficiency. Minimum acceptable efficiency at the operating point will be 60 percent. The minimum required horsepower for the motor must be capable of handling the entire range as shown in the pump curve. Where necessary, a higher horsepower pump will be required to prevent any damage to the motor as a result of loss of hydraulic head situation.
- (D) All submersible pumps shall be equipped with an automatic flush valve attached to the pump volute using the hydraulic energy created by the pump operation to temporarily suspend settled materials.
- (E) The pump rail system shall be MTM Sch 40 stainless-steel with supports on eight (8) feet maximum spacing.



#### SUBSECTION 5.04.06.02 | PUMP CAPACITY

- (A) The firm pumping capacity shall be greater than the peak flow for the entire fully developed drainage basin. If the fully developed drainage basin is significantly larger than the proposed development and it is not feasible to design for this flow, the firm capacity may be designed to handle a portion of the basin with the ability to expand for the ultimate basin capacity with approval from the City Engineer.
- (B) The pump curves shall be selected so that during normal operating conditions the pumps will run near the best efficiency point. The curves shall not approach shut off head when the pumps are running together.
- (C) System head curves, pump curves, and head calculations shall be submitted. Calculations and pump curves at both minimum (*all pumps off*) and maximum (*last normal operating pump on*) static heads, and for a C value of both 100 and 140 must be provided for each pump and for the combination of pumps with modified pump curves. Head calculations shall be the sum of static head, friction head in force main and lift station piping, and a fittings head.
- (D) Flow calculations, system curves, and head calculations shall be shown in the construction drawings as well as in a final design report. Final design report shall include all of the preliminary design submittal requirements with the exception of the replacement of final design information.

#### SUBSECTION 5.04.06.03 | LIFT STATION PIPING

- (A) Piping inside the lift station shall be ductile iron Class 200 PSI, AWWA C151-75, C171-76, or latest edition thereof. Pipe shall be centrifugally cast with rubber gasket type joint. All fittings shall be ductile iron Class 250 meeting AWWA C110-77 or latest revision for sizes 12-inches and smaller or Class 150 on sizes 14-inches and larger. All pipe and fittings shall have a prime coat on the outside surface and shall have an interior lining of 40-mils nominal dry film thickness of Protecto 401 Ceramic Epoxy Lining or approved equal, applied in accordance to the manufacturer's recommendations.
- (B) All nut and bolt assemblies inside the wet well shall be ASTM 316 stainless-steel.
- (C) Lift station piping shall be designed with an additional emergency by-pass pump connection, allowing the station to be operated with the primary pump(s) out of service for an extended period of time. The by-pass pump connection shall be fitted with a CamLock fitting and cap. Bypass piping shall be supported by a strut type pipe support set in a reinforced concrete pad. By-pass piping and valves shall maintain a minimum of a 24-inch clear from the ground.

#### SUBSECTION 5.04.06.04 | VALVES

*(Isolation valves, check valves, and air release/vacuum valves shall be located in the valve vault)*

##### (A) Isolation Valves.

- (1) Each pump shall have one isolation valve downstream of the pump and check valve, including a discharge pressure gauge between the pump and isolation valve. Isolation valves shall be resilient seated gate valves meeting the City Standard Specifications. The discharge pressure gauge shall be a minimum of four (4) inch diameter within the appropriate pressure ranges for the design.
- (2) All external nuts and bolts shall be ASTM 316 stainless-steel.

##### (B) Check Valves.

- (1) Check valves shall be a controlled closing swing check valve with a lever and spring.
- (2) Check valves shall be located upstream of the isolation valve.
- (3) All external nuts and bolts shall be ASTM 316 stainless-steel.

##### (C) Air Release/Vacuum Valves.

- (1) Air release valves of a type suitable for wastewater service shall be installed along the force main where the force main would be prone to trapped air.
- (2) The type of valve shall be air release or a combination of air release and vacuum breaker. Valves shall be fitted with blow off valves, quick disconnect coupling and hose to permit back flushing after installation without dismantling the valve.
- (3) All external nuts and bolts shall be ASTM 316 stainless-steel.



- (4) The engineer shall determine the valve type and location. The calculations for valve type and valve sizing shall be provided to the City Engineer.
- (5) Isolation valves for three (3) inch and smaller air release valves shall be all bronze or brass. Isolation valves four (4) inch and larger shall meet standard specifications for resilient wedge gate valve.
- (6) Locations of the air release/vacuum valves shall be shown on the plan and profile sheets for the force main.

### SUBSECTION 5.04.07 | FORCE MAIN

#### SUBSECTION 5.04.07.01 | GENERAL

- (A) Force main capacity shall be sized to meet the pump capacity. The force main shall be sized to handle the ultimate basin capacity. The force main may be designed to handle a portion of the basin with the ability to expand for the ultimate basin capacity if approved by the City Engineer. The minimum force main size shall be four (4) inch diameter except for grinder pump lift stations. The minimum recommended velocity is three (3) feet per second, and the velocity shall not be less than 2.50-feet per second when only the smallest pump is in operation.
- (B) Force main sewer pipe shall be designed to meet the working pressure requirements of the particular application. Design calculations and pipe selection shall be submitted to the City Engineer in report format.
- (C) A force main must be designed to abate any anticipated odor.
- (D) Force main pipe materials shall AWWA C900-16 PVC Pipe (*green in color*) for all sizes, DR 14 (PC 305) for pipeline sizes 12-inch and smaller, and DR 18 (PC 235) for 14-inch and larger wastewater pipelines.
- (E) For trench depths greater than 12-feet or other dead and/or live loading considerations, the engineer shall provide a pipe with the appropriate DR rating which shall exceed the minimum requirements.
- (F) All fittings shall be wrapped ductile iron in accordance with AWWA C110 or AWWA C153. Fittings shall have a prime coat on the outside surface and shall have an interior lining of 40-mils nominal dry film thickness of Protecto 401 Ceramic Epoxy Lining or approved equal, applied in accordance to the manufacturer's recommendations.
- (G) Isolation valves shall be a maximum spacing of 1,000-feet and at critical locations along the force main.
- (H) All valves and fittings shall be restrained with Mega-lug or approved equal. Joint material for PVC shall conform to ASTM F471.
- (I) Plans shall include plan and profile for the force main.
- (J) Force main shall have a minimum of four (4) feet of cover and be laid to standard specifications for potable waterline.
- (K) Force main separation and design criteria from water mains and all other utility lines shall meet the minimum requirements from TCEQ.
- (L) All force mains shall have green EMS locator pads at every 250-feet, change in direction, valve, manhole, etc.

#### SUBSECTION 5.04.07.02 | EMBEDMENT

All force main pipes shall be installed in embedment material as shown on the *Standard Details* and in conformance for the *Standard Specification for Construction*.

### SUBSECTION 5.04.08 | CONTROL PANEL

#### SUBSECTION 5.04.08.01 | GENERAL

The control system shall be designed to operate the required number of pumps specified on the drawing at the power characteristics shown on the plans.

The control function shall provide for the operation of the pumps in Hand (manual) and Auto (controlled by PLC). See *24VAC Regulator System* for further information. The control shall function as described below. The equipment listed below is a guide and does not relieve the supplier from providing a system that will function as required.





#### SUBSECTION 5.04.08.02 | ENCLOSURE

The enclosure shall be a NEMA 4x rated stainless-steel. The enclosure shall be a wall mount type with a minimum depth of eight (8) inch sized to adequately house all the components. The door gasket shall be rubber composition with a retainer to assure a positive weatherproof seal. The door shall operate with a single action handle that accepts a 3/8-inch shaft padlock and opens a minimum of 180 degrees.

#### SUBSECTION 5.04.08.03 | INNER DEAD DOOR

A polished aluminum dead front shall be mounted on a continuous aircraft type hinge, contain cutouts for mounted equipment, and provide protection of personnel from live internal wiring. Cutouts for breaker handles shall be provided to allow operation of breakers without entering the compartment. No door mounted operating mechanisms allowed for breaker operation. All control switches, indicator pilot lights, ONE general purpose GFI duplex receptacle and other operational devices shall be mounted on the external surface of the dead front. The dead front shall open a minimum of 150 degrees to allow access to equipment for maintenance. A 3/4-inch break shall be formed around the perimeter of the dead front to provide rigidity.

#### SUBSECTION 5.04.08.04 | BACK PLATE

The back plate shall be manufactured of 12-gauge sheet steel and be finished with a primer coat and two (2) coats of baked on white enamel. All devices shall be permanently identified.

#### SUBSECTION 5.04.08.05 | POWER DISTRIBUTION

The panel power distribution shall include all necessary components and be wired with stranded copper conductors rated at a minimum of 90 degrees C.

System shall be equipped with an Emergency Generator with an automatic transfer switch capable of programmable test dates and times. Inputs shall be provided to PLC to indicate Generator Running, Generator Alarm, and Generator Low Fuel Level OR a Stand Alone Manual Double Throw Safety Switch to allow hard wiring to a portable generator. Emergency Generator shall meet the requirements of the most recently adopted noise ordinance and be a minimum Level I noise control compliant.

No door mounted operating mechanisms allowed for breaker operation in control panel. All conductor terminations shall be as recommended by the device manufacturer.

#### SUBSECTION 5.04.08.06 | CIRCUIT BREAKERS

All circuit breakers shall be heavy-duty thermal magnetic or motor circuit protectors similar and equal to Square D type FAL. Each motor breaker shall be adequately sized to meet the pump motor operating characteristics and shall have a minimum of 10,000 amps interrupting capacity for 230 VAC and 14,000 amps at 480 VAC. The control circuit and the duplex receptacles shall be individually controlled by heavy-duty breakers.

Circuit breakers shall be indicating type, providing "ON-OFF-TRIP" positions of the operating handle. When the breaker is tripped automatically, the handle shall assume a middle position indicating "TRIP".

Thermal magnetic breakers shall be quick-made and quick-break on both manual and automatic operation and have inverse time characteristics secured through the use of bimetallic tripping elements supplemented by a magnetic trip.

Breakers shall be designed so that an overload on one pole automatically trips and opens all legs. Field installed handled ties shall not be acceptable.

#### SUBSECTION 5.04.08.07 | MOTOR STARTERS

Motor starters shall be open frame, across the line, NEMA rated with individual overload protection in each leg. Motor starter contact and coil shall be replaceable from the front of the starter without being removed from its mounted position. Overload heaters shall be solid state motor logic type with the following features: [1] three (3) to one (1) adjustment for trip current, [2] phase loss and unbalance protection, [3] LED power indication, [4] ambient insensitive and self-powered, and [5] shall have availability of electrical remote reset. Overloads shall be sized for the full load amperage draw of the pumps. Definite purpose contactors, fractional size starters and horsepower rated contactors or relays shall not be acceptable.



#### SUBSECTION 5.04.08.08 | TRANSFORMERS

Control transformers shall provide the 120 VAC and/or 24 VAC for control circuits. Transformers shall be fused on the primary and secondary circuits. The secondary shall be grounded.

#### SUBSECTION 5.04.08.09 | LIGHTING-TRANSIENT PROTECTION

A lightning-transient protector with tell-tale warning lights on each phase to indicate loss of protection on the individual phases shall be provided. The device shall be solid state with a response time of less than five (5) nanoseconds withstanding surge capacity of 6,500 amperes. Unit shall be instant recovery, long life and have no holdover currents.

#### SUBSECTION 5.04.08.10 | PHASE MONITOR

A line voltage rated, adjustable phase monitor shall be installed to sense low voltage, loss of power, reversed phasing and loss of a phase. Control circuit shall de-energize upon sensing any of the faults and shall automatically restore service upon return to normal power.

#### SUBSECTION 5.04.08.11 | ALARM SYSTEM

The alarm light shall be a weatherproof, shatterproof, red light fixture with 500 lumens minimum to indicate alarm conditions. The alarm light shall be turned on by the alarm level.

The alarm light shall be mounted on the exterior of the cabinet. The alarm horn shall provide an audio signal of not less than 90 DB at ten (10) feet. An alarm silence switch shall be mounted on the exterior of the cabinet and deactivate the alarm horn; however, the alarm light shall flash until the alarm condition ceases to exist. An Input shall be provided to PLC to indicate High Wet Well Condition.

#### SUBSECTION 5.04.08.12 | VAC REGULATOR SYSTEM

SCADA. Equipment for SCADA shall consist of a PLC, Radio, Antenna, etc. to operate the system. Control cabinet components shall be installed when the panel is built. Engineer shall contact the Pump Department at 972-771-7730 for current requirements for SCADA system and contact for City's current SCADA supplier. The control system shall provide for both automatic and manual control and alternation of the pumps to maintain a pumped down condition of the wet well.

Wet well levels shall be sensed by a pressure transducer. Float regulators shall be installed as back up for HIGH and LOW levels only. The transducer shall sense the "OFF", "LEAD", "LAG", and "HIGH" levels as given on the plans. As the level in the wet well raises the lead pump, as determined by the alternator, shall start and pump the station to the "OFF" position. In the event the incoming flow exceeds the capacity of the lead pump, the lag pump shall start and both pumps shall run to the off level. If the wet well level continues to rise, high well alarm functions shall be activated. The alternator shall switch when the off level is reached.

All inputs and outputs shall be wired to a terminal strip at bottom of cabinet.

#### SUBSECTION 5.04.08.13 | ANCILLARY EQUIPMENT

- (A) HOA Switches. A three (3) position HOA switch shall be provided on the inner dead front for each pump. Inputs shall be provided to PLC to indicate position of HOA.
- (B) Run Indicators. A run pilot indicator shall be provided on the inner dead front. All indicator lights shall be push to test. Inputs shall be provided to PLC to indicate pump running.
- (C) Elapsed Time. Elapse time meter shall be mounted on the dead front door.
- (D) Cabinet Temperature Control. The cabinet shall be equipped with a panel heater controlled by a thermostat and a vent fan controlled by a thermostat.
- (E) Receptacles. One (1) duplex receptacle located on inner dead front door for general purpose use. This receptacle shall be of the ground fault type, 120 volts, and protected by a 20-amp breaker. A second single receptacle shall be located on the back panel to provide power for UPS back up system. This receptacle shall be 120 volts and protected by a separate 20-amp breaker.



- (F) UPS Back Up System. Will provided 120 volts power to SCADA communication equipment and all low voltage power transformers. This must be installed in the control panel. UPS shall be APC 650VA 120 volts or equivalent. The System must be able to transmit all alarms and wet well levels when on backup power.
- (G) Motor Protection. A control and status module shall sense either motor over temperature or seal leakage, and shall turn off the pump, lock out the pump, and send an alarm. Inputs shall be provided to PLC to indicate Pump Fail, Seal Fail and Temp Fail individually for each pump.

#### SUBSECTION 5.04.08.14 | MISCELLANEOUS

- (A) Panel Racks. Posts supporting racks shall be three (3) inch minimum rigid conduit capped and bolted directly to channel framework supporting the panels. Panels shall have a “rain shield” structure using ¼-inch minimum aluminum plating providing a solid back plate behind panels continuous to overhead plate to protect panel from rain. Provide lighting mounted on structure with switch mounted on exterior of panel to light up panel area. Contact City of Rockwall at 972-771-7730 for location of existing type structure. Each pump must have its own conduit for power cord and a separate conduit for all float wires.
- (B) Drawings. Control panel schematic drawings shall be submitted for approval with the submittal plans. Final control panel wire schematic drawings including a list of all legends (*two [2] sets total*) shall be provided. One (1) set shall be encapsulated in Mylar and attached to the inside of the front door of the control cabinet. A second set shall be delivered to the City of Rockwall Wastewater Department.
- (C) Panel Markings. All component parts in the control panel shall be permanently marked and identified as they are indicated on the drawing. Marking shall be on the back plate adjacent to the component. All control conductors shall be identified with wire markers as close as practical to each end of conductors.
- (D) Panel Wiring. All wiring in panel shall maintain a minimum of 1½-inch spacing between components and wire ways.
- (E) Testing. All panels shall be tested to the power requirements as shown on the plans to assure proper operation of all the components. Each control function shall be activated to check for proper operation and indication.
- (F) Guarantee. All equipment shall be guaranteed for a period of three (3) years from date of acceptance. The guarantee is effective against all defects in workmanship and/or defective components. The warranty is limited to replacement or repair of the defective equipment.





## CHAPTER 6 | MISCELLANEOUS REQUIREMENTS

### SECTION 6.01 | GRADING

All backfill or grading material shall be placed in layers not to exceed eight (8) inches loose thickness. The moisture content shall be uniform and near the optimum moisture content for the material. In cases where the materials being placed do not have the proper moisture, the material shall be dried out or additional moisture shall be added by satisfactory methods such that the additional water is distributed uniformly throughout the material being placed. The layers of the backfill shall be reduced in thickness when satisfactory compaction cannot be obtained with the equipment being used. In all cases, a density of not less than 95 percent of the standard proctor density must be obtained. The contractor shall arrange for the necessary laboratory testing, at their expense, to determine the density of the material. All density reports shall be provided to the City of Rockwall. All franchise utility companies (*phone, gas, electrical, cable, internet, and any utility that isn't supplied by the City*) working within the rights-of-way of streets or alleys shall also comply with the above noted specifications with laboratory testing results provided to the City of Rockwall. Easement locations under pavement shall also have a minimum density control backfill to 95 percent of the standard proctor density. All densities are to be within the acceptable moisture range of (-2 to +4) percent of optimum moisture unless otherwise approved by the City Engineer.

A sheep's-foot roller shall be utilized for compaction of all fill material. Mechanical tamping is allowed for trench backfill. The sheep's-foot roller is to be on-site and active whenever fill material is being placed.

It shall be the responsibility of the Developer to adjust all City and franchise utilities to the final grades of the development. Depending on changes in grade over existing utilities, utility relocation may be required.

All slopes should be a maximum of four (4) to one (1) (*or 4:1*) and a minimum of one (1) percent. In locations where a four (4) to one (1) (*or 4:1*) slope is not possible, retaining walls, gabion baskets, concrete slope protection or other approved retaining methods may be required. Retaining methods must be approved by the City Engineer.

At the beginning of the project the Developer will provide offset stakes at intervals of 50-feet. The stakes will be offset from the back of the outside curb, a convenient distance to permit all operations, to be completed without disturbing these stakes. Information that shall be included on the stakes includes the station number, offset distance from back of curb, and elevations of hub. It will be the contractor's responsibility to maintain these stakes, and use the information for all other horizontal and vertical control required. The contractor will set all forms using the data shown on the approved plans.

### SECTION 6.02 | GRADING, FILL, EXCAVATION, AND EARTHWORK PERMIT

A grading, fill, excavation and earthwork permit shall be obtained prior to stockpiling or filling property within the City limits. No filling in drainage swales, creeks, wetlands, flood plains, etc. is allowed without a flood study approval. Erosion protection shall be installed around stockpiled or stored material until grass is established. If fill is placed for use other than stockpiling or storage, a grading plan shall be prepared by a Professional Engineer and submitted with the grading, fill, excavation and earthwork permit. Temporary stockpiles have a maximum time limit of six (6) months. Densities shall be taken and proper compaction techniques used when placing the fill. In all cases, a Professional Engineer shall certify that the proposed fill location is not within a stream, creek (*flowing or not*), or floodplain. If the City Engineer determines the fill is to be placed near a creek or stream or possible drainage way, the 100-year floodplain shall be staked by a registered surveyor.

Grading for the parcels/development will only be released with final construction plan release by the Engineering Department.

Residential (including infill) lots shall submit a grading plan with the building permit. This is to ensure drainage and structure elevations will meet City requirements.

The City of Rockwall requires that the design engineer provide a letter of concurrence. The letter is to verify that the drainage patterns, grade to drains locations, detention systems including outfall structures, detention pond volume, pad elevations, and drainage structures located within the project scope were installed to the general elevations as shown on the approved plans. The letter shall also verify that the project was constructed to meet the approved design requirements or is within acceptable design tolerances (*max 0.2-feet for residential pad elevations*). The design engineer or their designated representative shall direct all survey work necessary to verify elevations and design compliance. The letter of concurrence is to have the seal and signature of the design engineer.



## SECTION 6.03 | PRIVATE UTILITY CONSTRUCTION

### SUBSECTION 6.03.01 | TRENCH BACKFILL IN CITY RIGHT-OF-WAY

- (A) No concrete streets shall be open cut by utility companies without City approval. Utilities crossing concrete streets shall be tunneled or bored (*dry only*). If open cut is approved by City, full panel replacement will be required to nearest joints. Additional pavement removal and replacement may be required for connection.
- (B) Asphalt streets may be open cut. Backfill above utilities shall be concrete stabilized sand or cement. The asphalt pavement shall be repaired per City detail.
- (C) All trench backfill is to be compacted to 95 percent *Standard Proctor Density* within City rights-of-way. The compaction may be obtained by mechanical tamping, rolling, etc. No water jetting is allowed. In the parkway, the backfill material may be from the excavated trench, except no rocks larger than two (2) inches shall be used. Material from rock or shale excavation cannot be used. The contractor for the utility company or the utility company shall furnish density reports from a material testing company verifying the densities. Densities shall be taken at each 12-inches lift at a maximum spacing of 150-feet. The moisture content shall be uniform and near the optimum moisture content for the material. In cases, where the materials being placed do not have the proper moisture, the material shall be dried out or additional moisture shall be added by satisfactory methods such that the additional water is distributed uniformly throughout the material being placed.

### SUBSECTION 6.03.02 | PARKWAY CLEANUP

The contractor for the utility company or utility company shall remove any rocks or excess trench material from the parkway and replace any disturbed areas with grass sod.

## SECTION 6.04 | ADDITIONAL PERMITS OR APPROVALS

Developer or developer's representative is responsible for obtaining any other approvals or permits needed for their development, for example: TCEQ, TXDOT, City of Dallas, FEMA, USACOE etc. prior to start of construction. Copies of the permits/approvals shall be furnished to the City.

## SECTION 6.05 | RETAINING WALLS

- (A) Retaining walls or concrete slope protection shall be installed where lot slope is greater than four (4) to one (1) (*or 4:1*).
- (B) No railroad tie, wood, or steel retaining walls shall be constructed in public or private property.
- (C) No retaining walls, including the footings, shall be placed in the right-of-way, easements, detention ponds or overlapping property lines. Retaining walls shall be entirely on the lot with the higher elevation.
- (D) All retaining walls (*18-inches and taller*) shall be stone, masonry or reinforced concrete with a stone face or form liner. No smooth concrete retaining walls to be installed.
- (E) Retaining walls three (3) feet and taller shall be designed (*signed and sealed*) and inspected by a professional licensed engineer in the State of Texas. Property lines and rights-of-way shall be noted on the wall plans. The City requires a verification letter (*signed/sealed*) from the design engineer stating that the retaining walls installed with the site/subdivision were inspected by the engineer or their designated representative and that the walls were installed to the engineered design and general construction standards. The verification letter shall be delivered to the Engineering Department prior to the project acceptance by the City.
- (F) Retaining walls over 30-inches in height that have sidewalk, trail or other walking surface on the top side of the wall will require railing.
- (G) Traffic rated guard rail or barrier will be required when roadway, parking lot, drive isle or alley is within ten (10) feet of a retaining wall that is over 30-inches in height. Details of the railing or barrier shall be provided in the engineering plans.
- (H) The design of retaining walls (*not screening walls*) in close proximity to trash enclosures shall take into account the weight of a fully loaded dumpster, fully loaded trash truck, and the force exerted when the dumpster is placed back on the ground in the enclosure.
- (I) Gabion retaining walls may be used only with City Engineer's approval for walls less than three (3) feet along drainage ways.
- (J) All retaining walls shall be placed according to offset hubs set by certified professional surveyors noting grade cuts, wall elevations and stop points for each wall end. Wall locations and elevations shall match those shown on the approved site grading plans.



- (K) All retaining wall plans shall indicate property lines, swales, and rights-of-way. If the retaining wall is designed to be the high point of the lot/area, the wall shall have a stone cap that is installed a minimum of six (6) inch above the final adjacent grade.

## SECTION 6.06 | MAINTENANCE BONDS

The City requires ten (10) percent two (2) year maintenance bond for paving, paving improvements, water systems, wastewater systems, storm sewer systems including detention systems, and associated fixtures and structures which are located within the rights-of-way or defined easements. The two (2) year maintenance bond is to state “from date of City acceptance” as the starting time.

A review of the site shall be conducted at 20-months into the two (2) year maintenance period. The design engineer or their designated representative shall be present to walk the site with the City of Rockwall Engineering Inspection personnel.

## SECTION 6.07 | CONSTRUCTION

### SUBSECTION 6.07.01 | PRELIMINARY SITE PREPERATION

Site Preparation. The below noted site preparation items are to be in place, inspected and approved by the City, prior to the start of any clearing, grubbing or grading operations.

- (A) Protected trees which are designated to remain on site are to be identified, tagged and banded with bright orange or red bands.
- (B) Protected trees which are designated to be removed from the site are to be identified tagged and banded with blue bands or blue paint markings.
- (C) Tree identification tags are to consist of metal tags which have the tree identification number stenciled or stamped or engraved on the tag. The numbers used to identify the protected trees shall correspond to the tree identification number noted on the approved treescape plans.
- (D) Protected Tree Barrier Fencing.
- (1) Chain link barrier fencing shall be placed around the drip lines of the individual protected trees or groups of protected trees, which are designated to remain at the site if they are located within ten (10) feet of any cut/fill grading location.
  - (2) Plastic mesh barrier fencing shall be placed around the drip lines of individual protected trees or groups of protected trees, which are located over ten (10) feet or more outside a cut/fill grading location.
- (E) Silt fence along with construction entrance and any other designated erosion BMP's must be installed and inspected. No silt fencing may be installed at the site until the trees have been identified, banded, tagged, fenced and inspected by the City. Silt fence should not be installed within a floodplain.
- (F) Portable toilet facilities will be required on all construction sites or as otherwise deemed necessary by the City of Rockwall. It is essential that adequate on-site restroom facilities be available for all construction workers. It will be the responsibility of the contractor to install and maintain the facilities through the completion of the project. These facilities must be on site and verified prior to moving personnel on site and before construction can begin.
- (G) Portable trash receptacle is to remain on the job site through the course of construction. The site is to remain free of construction litter and debris. Construction workers shall place all lunch trash in the “trash containers” immediately after lunch. Trash receptacle must be on site and verified prior to moving personnel on site and before construction can begin.
- (H) If a detention pond system is required per the plans, the detention pond must be installed with outfall structure and soil stabilization before pavement or slab may be placed.
- (I) Construction Site Working Hours and Noise Control Signage. Construction and construction related activities are limited to the hours of 7:00 AM to 7:00 PM Monday through Friday and 8:00 AM to 7:00 PM on Saturday. No Sunday construction allowed. The City of Rockwall requires that a sign be posted at each Commercial/Residential development construction site. The sign must be installed at the site and verified prior to moving personnel on site and before construction can begin. The construction related activities are to include but not be limited to the following:
- (1) Maintenance, servicing and fueling of construction equipment.
  - (2) The delivery of construction related materials and/or construction equipment.



At locations where compliance to *Ordinance 05-45* is not being observed, the City of Rockwall may issue written orders to stop work or further regulate the site construction work hours. The City may also issue citations if it is determined that a violation of the construction ordinance exist.

### CONSTRUCTION SITE SIGN EXAMPLE

**Ordinance # 05-45  
Construction Site Working Hours and Noise Control**

City *Ordinance No. 05-45* limits construction and construction related activities to the hours of 7:00 AM - 7:00 PM Monday through Friday, and 8:00 AM - 7:00 PM on Saturday. (NO SUNDAY CONSTRUCTION ALLOWED).

**ORDENANZA #05-45  
HORAS DE TRABAJO EN EL SITIO DE CONSTRUCCION Y EL CONTROL DE RUIDO**

*La Ordenanza de la Ciudad No. 05-45* limita la construcción y las actividades relacionadas con la construcción a las horas de 7:00 AM – 7:00 PM de Lunes a Viernes, y de 8:00 AM – 7:00 PM los Sábados. (NO SE PERMITIRÁ CONSTRUCCIÓN LOS DOMINGO).

#### **GENERAL NOTES:**

NOISE ORDINANCE SIGN | SIGN SIZE THREE (3) FEET WIDE BY TWO (2) FEET TALL.

### SUBSECTION 6.07.02 | INSPECTION SCHEDULING

It is the responsibility of the contractor to schedule inspections prior to construction. Inspections may be scheduled and coordinated in the field or by cell phone directly with the Engineering Department Construction Inspector. Inspection of construction and verification of compliance to plans and specifications shall be conducted by the City of Rockwall Engineering Construction Inspector. The general contractor shall notify all of his construction contractors of this requirement. Items to be inspected must be sufficiently ready for inspection at the time of your requested inspection appointment as inspector's time is limited. Failure to be ready for inspections may result in inspection rescheduling to the following day. No development will be accepted by the City of Rockwall until all construction has been approved by the City of Rockwall inspectors.

- (A) Saturday Inspections. The contractor will be charged a minimum two (2) hours inspection charge for all Saturday inspections. All Saturday inspections must be scheduled in writing to the Engineering Department by noon on the Thursday before the inspection date. A signed Saturday Engineering Inspection Request form must be emailed to the City Engineer and Construction Inspector Supervisor. Approval/disapproval will be emailed back to the requesting contractor with the Saturday inspector's information. All cancellations must be given verbally and in writing to the Saturday inspector no later than 8:00 AM on day of inspection. Two (2) hours of overtime inspection will be charged to the contractor if no cancellation is given prior to the inspector arriving at the project site. Contractor must sign form to finalize the inspection. No acceptance and/or certification of occupancy will be given until all overtime engineering inspection fees are paid in full. If any City holiday occurs on a Friday, there will be no inspections or inspectable construction on the Saturday after this holiday. If any City holiday occurs on a Monday, there will be no inspections or inspectable construction on the Saturday prior to this holiday.
- (B) Before/After Weekday Hours Inspections. Contractor will be charged on 15-minute intervals for any before/after hour's inspections. Contractor must sign form to finalize the inspection. No acceptance and/or certification of occupancy will be given until all overtime engineering inspection fees are paid in full.

### SUBSECTION 6.07.03 | VERTICAL ABOVE SLAB CONSTRUCTION PERMIT

No vertical (above slab) construction will be allowed until such time as the following minimum site requirements have been addressed at the site, verified by a City Representative, and a vertical above slab construction permit has been issued. Minimum requirements for vertical construction are subject to but not necessarily limited to the below noted items:

- (A) Fire lane pavement is installed, tested, and approved for use
- (B) Fire lane pavement is painted and marked to Fire Department specifications
- (C) Water lines for the site are installed, tested, and approved for use





- (D) All fire hydrants are installed and approved for use
- (E) Fire hydrant nozzles and bonnets are painted as per line size color code
- (F) Reflective fire hydrant locator buttons are in place at hydrant pavement locations
- (G) Fire hydrants are flow tested to verify flow at designated hydrant locations
- (H) Fire hydrant nozzle diameters, proper height above final grade, and clearance are verified and approved
- (I) Silt fence is placed above the fire lane if it is deemed necessary at positive flow areas
- (J) Exterior building materials are approved by the Planning and Zoning Department.

#### SUBSECTION 6.07.04 | DISPOSAL OF EXCESS MATERIALS

The contractor shall properly dispose of all excess material by removing from the job site all the brush, trash, debris, etc. upon completion of construction. All material shall be properly disposed outside of the City limits. No dumping of dirt inside the City of Rockwall without a permit.

#### SUBSECTION 6.07.05 | DISPOSAL OF EXCESS MATERIALS

Construction site safety measures are to be in place at all construction projects located within the City of Rockwall. All necessary measures required to ensure that safe work zones exist for the protection of construction workers and general public living in or near such construction zones. Construction zones shall comply with work zone traffic control specifications and requirements. Occupational Health and Safety Administration requirements and regulations must be in compliance. Temporary construction fencing is to be placed around open trenches, pits, or other locations deemed necessary by the City of Rockwall. Any miscellaneous items that may pose direct or potential hazard to workers or the general public that is known by the contractor or brought to the attention of the contractor shall be addressed immediately.

It is the responsibility of the contractor(s) to establish and maintain construction site safety measures; however, the City of Rockwall will temporarily suspend work at a construction site if it is deemed necessary due to unsafe or hazardous conditions until such conditions have been corrected.

In each circumstance where it is deemed that proper safety measures are not being followed, a warning will be issued by the Engineering Construction Inspector. Construction may be temporarily suspended if deemed necessary until items responsible for issuance of the safety warning have been properly addressed. Issuance of three (3) or more safety warnings will require that the designated construction be suspended until such time that a safety meeting is scheduled with contractor personnel along with City of Rockwall representatives to discuss the appropriate measures to correct the identified problems and determine any further possible actions which may be necessary.





## CHAPTER 7 | SPECIAL PROVISIONS TO THE NCTCOG'S STANDARD SPECIFICATIONS FOR PUBLIC WORKS CONSTRUCTION STANDARDS

All work included as a part of this contract shall be performed in accordance with the Standard Specifications for Public Works Construction, North Central Texas, November 2017, Fifth Edition, except where noted otherwise in the City of Rockwall's Supplemental Special Provisions, the Special Conditions included in the Specifications and Contract Documents.

The North Central Texas Standard Specifications shall be modified and clarified by the addition to the following requirements to the various items. Except when specifically stated, none of the requirements of the North Central Texas Standard Specifications shall be deleted.

### SECTION 7.01 | DIVISION 100. GENERAL PROVISIONS

*NOTE:* THE (1) SYMBOL SPECIFIES THAT THIS ITEM IS ALSO COVERED IN THE CITY OF ROCKWALL'S "SPECIAL PROVISIONS" TO THE "STANDARD SPECIFICATIONS FOR PUBLIC WORKS CONSTRUCTION, NORTH CENTRAL TEXAS". THESE SPECIAL PROVISIONS ARE ADDITIONAL AND MODIFY THE "STANDARD SPECIFICATION"

TABLE 7.1: REVISIONS TO NCTCOG'S DIVISION 100 GENERAL PROVISIONS

REVISED	STANDARD SPECIFICATION ITEM NO.	DESCRIPTION
	<b>101</b>	<b>DEFINITIONS AND ABBREVIATIONS</b>
	101.1	DEFINITIONS
	101.2	ABBREVIATIONS AND ACRONYMS
	<b>102</b>	<b>PROPOSAL PROCEDURES</b>
	102.1	PROPOSAL FORM
	102.2	QUANTITIES IN PROPOSAL FORM
	102.3	EXAMINATION OF PLANS, SPECIFICATIONS AND SITE OF THE WORK
	102.4	PREPARATION OF PROPOSAL
	102.5	PROPOSAL GUARANTY
	102.6	FILING OF PROPOSALS
	102.7	WITHDRAWING PROPOSALS
	102.8	OPENING PROPOSALS
	102.9	CONSIDERATION OF PROPOSAL
	102.10	IRREGULAR PROPOSALS
	102.11	REJECTION OF PROPOSALS
	102.12	DISQUALIFICATION OF BIDDERS
	102.13	RETURN OF PROPOSAL
	<b>103</b>	<b>AWARD AND EXECUTION CONTRACT</b>
	103.1	CONTRACTOR'S WARRANTIES AND UNDERSTANDING
(1)	103.2	AWARD OF CONTRACT
	103.3	SURETY BONDS
(1)	103.4	INSURANCE
	103.5	EXECUTION OF CONTRACT
	103.6	NOTICE TO PROCEED AND COMMENCEMENT OF WORK
	103.7	DELAY OF CONTRACT
	103.8	ORDER OF WORK TO BE PERFORMED
	<b>104</b>	<b>SCOPE OF WORK</b>
	104.1	INTENT OF CONTRACT DOCUMENTS
	104.2	CHANGE OF MODIFICATION OF CONTRACT
	104.3	DISRUPTED WORK AND CLAIMS FOR ADDITIONAL COMPENSATION
	104.4	PERFORMANCE OF EXTRA DISPUTED WORK



	<b>105</b>	<b>CONTROL OF WORK</b>
(1)	105.1	CONTRACT OF DOCUMENTS
(1)	105.2	WORKMANSHIP, WARRANTIES AND GUARANTEES
(1)	105.3	SHOP DRAWINGS, PRODUCT DATA AND SAMPLES
(1)	105.4	CONSTRUCTION STAKES
(1)	105.5	MEANS AND METHODS OF CONSTRUCTION
	105.6	SUPERVISION BY CONTRACTOR
(1)	105.7	OWNER'S REPRESENTATIVES
	105.8	SERVICE OF NOTICES
	105.9	INSPECTION
(1)	105.10	ACCEPTANCE
	<b>106</b>	<b>CONTROL OF MATERIAL</b>
	106.1	SUBSTITUTION OF MATERIALS
	106.2	MATERIALS AND EQUIPMENT
	106.3	SALVAGEABLE MATERIAL
	106.4	OFF-SITE STORAGE
	106.5	SAMPLES AND TESTS OF MATERIALS
	106.6	SURPLUS MATERIAL
	<b>107</b>	<b>LEGAL RELATIONS AND CONTRACT RESPONSIBILITIES</b>
	107.1	CONTRACTOR INDEPENDENCE
	107.2	NO THIRD-PARTY CONTRACTUAL RIGHTS
(1)	107.3	INDEMNIFICATION
	107.4	OWNER'S OFFICERS, EMPLOYEES OR AGENTS
	107.5	VENUE AND GOVERNING LAW
	107.6	NO WAIVER OF LEGAL RIGHTS
	107.7	SEVERABILITY
	107.8	HEADINGS
	107.9	OBLIGATION TO PERFORM FUNCTIONS
(1)	107.10	PERFORMANCE OF THE WORK
	107.11	SUCCESSORS AND ASSIGNS
	107.12	SUPERVISION AND CONSTRUCTION OF PROCEDURES
	107.13	LABOR AND MATERIALS
(1)	107.14	EQUAL EMPLOYMENT OPPORTUNITY
(1)	107.15	STATE AND LOCAL SALES AND USE TAXES
	107.16	PATENTS
(1)	107.17	COMPLIANCE WITH LAWS
	107.18	SANITARY PROVISIONS
	107.19	PUBLIC CONVENIENCE AND SAFETY
(1)	107.20	PROTECTION OF WORK AND PERSONS AND PROPERTY
	107.21	PROJECT SIGNS
	107.22	WORKING AREA
	107.23	RAILWAY CROSSINGS
	107.24	EXISTING STRUCTURES, FACILITIES AND APPURTENANCES
	107.25	PROJECT CLEAN-UP
	107.26	DISPOSAL OF MATERIALS
	107.27	RESTORATION OF PROPERTY
	107.28	ENVIRONMENTAL COMPLIANCE
	<b>108</b>	<b>PROSECTUTION AND PROGRESS</b>



108.1	PROGRESS SCHEDULE
108.2	PROSECUTION OF THE WORK
108.3	OTHER CONTRACTORS; OBLIGATION TO COOPERATE
108.4	EMPLOYEES
108.5	SUBCONTRACTS
108.6	ASSIGNMENTS
108.7	OWNER'S RIGHT TO TEMPORARILY SUSPEND WORK
108.8	DELAYS; EXTENSION OF TIME; LIQUIDATED DAMAGES
108.9	CONTRACTOR DEFAULT: OWNER'S RIGHT TO SUSPEND WORK AND ANNUL CONTRACT
108.10	SUSPENSION BY COURT ORDER AGAINST THE OWNER
108.11	TERMINATION FOR CONVENIENCE OF THE OWNER
108.12	CLAIMS AGAINST OWNER AND ACTION THERON
108.13	USE OF COMPLETED PORTIONS OF WORK
<b>109</b>	<b>MEASUREMENT AND PAYMENT</b>
109.1	PAYMENT FOR LABOR AND MATERIAL; NO LIENS
109.2	PAYMENT FOR MATERIALS
109.3	PAYMENT FOR EXTRA WORK
109.4	PAYMENT WITHHELD
(1) 109.5	MONTHLY ESTIMATE, PARTIAL PAYMENTS, RETAINAGE, FINAL INSPECTION, ACCEPTANCE AND FINAL PAYMENT
109.6	WIRE TRANSFERS
<b>110</b>	<b>AIR QUALITY REQUIREMENTS FOR EQUIPMENT</b>
110.1	EQUIPMENT REQUIREMENTS
110.2	OPERATIONAL REQUIREMENTS
110.3	REPORTING TO OWNER
110.4	ENFORCEMENT

**ITEM 103 AWARD AND EXECUTION CONTRACT**

**103.2 AWARD OF CONTRACT**

*DELETE ITEM 103.2 IN ITS ENTIRETY AND SUBSTITUTE THEREFORE THE FOLLOWING:*

It is the intention of the Owner to award a contract for the work included in this project on the basis of the lowest acceptable bid submitted by a qualified bidder, as determined by the Owner.

Within five (5) working days after the bid opening, the low bidder shall submit such evidence as the Owner may require establishing the bidder's qualifications to satisfactorily perform the work included in this project. Information that may be required shall include the following:

- (1) Current Financial Statement.
- (2) Letter of Auditor's opinion.
- (3) Previous years Balance Sheet, Income Statement and Change of Financial Position.
- (4) List of projects that have been satisfactorily completed by the Bidder that are of the same general type as included in this contract, together with names, addresses and phone numbers or persons familiar with this work.
- (5) Other information that may be pertinent to the Bidder's Qualifications.

Should the bidder fail to produce evidence satisfactory to the Owner on any of the foregoing points he may be disqualified and the work awarded to the next bidder so qualifying.



The Owner will notify the successful bidder, in writing, within sixty (60) days after the date of receiving bids, of the acceptance of the proposal. The Contractor or Contractors shall complete execution of the required bonds and Contract within ten (10) days of such notice.

103.4 INSURANCE

*ADD THE FOLLOWING SUB-ITEM:*

103.4.6 BONDS AND INSURANCE

103.4.6.1 PERFORMANCE, PAYMENT AND OTHER BONDS

Contractor shall furnish Performance and Payment Bonds as security for the faithful performance and payment of all his obligations under the Contract Documents. These Bonds shall be, at all times, in amounts equal to the total Contract Price, and in such form as set forth in the Contract Documents and with such corporate sureties as are licensed to conduct business in the state where the Project is located and are named in the current list of "Surety Companies Acceptable on Federal Bonds" as published in the Federal Register by the Audit Staff Bureau of Accounts, U.S. Treasury Department. The Performance and Payment Bonds shall be expanded to include any extension of the Contract Period of total Price.

If the surety on any Bond furnished by Contractor is declared bankrupt or becomes insolvent or its right to do business is terminated in any state where any part of the Project is located in revoked, Contractor shall within five (5) days thereafter substitute another Bond and surety, both of which may be acceptable to the City.

103.4.6.2 Additional Bonds and Insurance

Prior to delivery of the executed Contract by City to the Contractor, City may require CONTRACTOR to furnish such other Bonds and such additional insurance in such form and with such sureties or insurers as the City may require.

ITEM 105 CONTROL OF WORK

105.1 CONTRACT OF DOCUMENTS

105.1.1 PRIORITY OF CONTRACT DOCUMENTS

*CHANGE THE FIRST SENTENCE OF ITEM 105.1.1 TO READ:*

In case of conflict between contract documents, priority of interpretation shall be in the following order: signed agreement, performance and payment bonds, addenda, special conditions, project (*or contract*) drawings and specifications, City of Rockwall Special Provisions to the Standard Specifications for Public Works Construction – North Central Texas, standard drawings, advertisement for bids, contractor's bid proposal and bid form.

105.1.3 CONTRACT DRAWINGS AND SPECIFICATIONS

*ADD THE FOLLOWING:*

In general, the number of copies of the plans and specifications furnished to the Contractor shall be limited to five (5). Additional copies may be obtained at cost of reproduction.

105.2 WORKMANSHIP, WARRANTIES AND GUARANTEES

105.2.2 SPECIAL WARRANTY



*ADD THE FOLLOWING:*

The Contractor shall provide a Maintenance Bond in the amount of ten (10) percent of the total amount of the contract guaranteeing the work in accordance with the plans and specifications for a period of two (2) years after acceptance by the City of Rockwall. This bond shall provide for repair and/or replacement of all defects due to faulty material and workmanship that appear within a period of two (2) years from the date of completion and acceptance of the improvements by the City of Rockwall.

105.3 SHOP DRAWINGS, PRODUCT DATA AND SAMPLES

*ADD THE FOLLOWING:*

Review of Shop Drawings by the Engineer shall be of the sole purpose of determining the sufficiency of the said drawings or schedules to result in finished improvements in conformance with the plans and specifications, and shall not relieve the Contractor of his duty as an independent contractor. It being understood and agreed that the Engineer does not assume any duty to pass upon the propriety or adequacy of such drawings or schedules or any means or methods reflected thereby in relation to the safety of either person or property during the contractor's performance hereunder.

105.4 CONSTRUCTION STAKES

*ADD THE FOLLOWING TO THE FIRST PARAGRAPH:*

The Contractor shall be required to utilize the control monuments provided in the plans to set horizontal and vertical control and construction staking with the contractor's own surveyor.

105.5 MEANS AND METHODS OF CONSTRUCTION

*ADD THE FOLLOWING:*

105.5.1 WATER FOR CONSTRUCTION

The Contractor shall make the necessary arrangements for securing and transporting all water required in the construction, including water required for mixing of concrete, sprinkling, testing, flushing, flooding or jetting. The Contractor shall provide water as required at his own expenses.

All construction meters are to be approved and tagged by the City of Rockwall. The tag is to remain on the meter at all times. If the tag is damaged or lost, immediately notify the Public Works Department. Any construction meter in use without a tag will be removed by City personnel. The use of any non-approved meters will result in the City of Rockwall charging for an estimated water usage and possible fines. All construction meters are to be equipped with a backflow prevention device with double check valves and dual test ports. All backflow devices shall have a Backflow Prevention Assembly Test and Maintenance Report from a certified backflow tester, when registering a meter at the City of Rockwall Service Center.

Any party requesting the use of a temporary meter on a fire hydrant in the City of Rockwall shall execute an agreement with the City of Rockwall and shall deposit with the City of Rockwall the amount required by ordinance. Such deposit shall be returned upon payment of all charges for water use, and upon return of the meter, fittings, and wrench in their original condition.

Stationary meters shall be locked to fire hydrants at all times. Installation, set up and service fees shall be in the amounts established by ordinance.

It shall be unlawful for any person to open or close any fire hydrant used to obtain water for any purpose with any tool or device other than a standard accepted fire hydrant wrench, which can be supplied by the City of Rockwall.



All stationary fire hydrant meters shall be read monthly at their location in the field. All mobile fire hydrant meters are to be brought to the Utility Maintenance Department, Rockwall, Texas, between the 1st and 10th of each month to be read. The location of all meters shall be disclosed in writing to the City of Rockwall's Water Department. If meter is relocated, written notification of new location must be made immediately to the City of Rockwall's Water Department.

Temporary fire hydrant meters shall be read monthly by representatives of the City of Rockwall, and bills rendered at the current rates for all consumption. Customers using such meters shall comply with the written procedures implemented by the City with regard to making the meters available to be read by representatives of the Rockwall Water Department. It shall be unlawful for any person to fail to make such meter available to be read by representatives of the Rockwall Utilities Department, as required by written procedures issued by the City.

Upon conviction of violation of the above requirements punishment shall be by fine not to exceed *TWO HUNDRED DOLLARS* (\$200.00). Each day on which a violation exists shall constitute a separate offense.

#### 105.7 OWNER'S REPRESENTATIVES

##### *ADD THE FOLLOWING:*

##### 105.7.3 OBSERVATION OF WORK BY ENGINEER

The Engineer shall make periodic visits to the site to familiarize himself/herself generally with the progress of the executed work and to determine if such work generally meets the essential performance and design features and the technical and functional engineering requirements of the Contract Documents; provided and except, however, that the Engineer shall not be responsible for making any detailed, exhaustive, comprehensive or continuous on-site inspection of the quality or quantity of the work or be in any way responsible, directly or indirectly, for the construction means, methods, techniques, sequences, quality, procedures, programs, safety precautions or lack of same incident thereto or in connection therewith. Notwithstanding any other provision of this agreement or any other Contract Document, the Engineer shall not be in any way responsible or liable for any acts, errors, omissions or negligence of the Contractor, any subcontractor or any of the Contractor's or subcontractor's agents, servants or employees or any other person, firm or corporation performing or attempting to perform any of the work.

#### 105.10 ACCEPTANCE

##### *ADD THE FOLLOWING:*

Once the work is satisfactory to the City of Rockwall and in accordance with the plans, specifications, contract documents, and the City has received; the Contractor's Affidavit of Final Payment and Release, Maintenance Bond, and Contractor's redlines/markups plans of actual work performed by the Contractor will the City issue a certificate of acceptance.

#### ITEM 107 LEGAL RELATIONS AND CONTRACT RESPONSIBILITIES

#### 107.3 INDEMNIFICATION

##### *DELETE ITEM 107.3 IN ITS ENTIRETY AND SUBSTITUTE THEREFORE THE FOLLOWING:*

The Contractor and his sureties shall indemnify, defend and save harmless the OWNER and all of its officers, agents and employees, ENGINEER and all of its officers and employees from all suits, actions or claims of any character, name and description brought for or on account of any injuries, including death or damages received or sustained by any person, persons or property on account of the operations of the Contractor, his agents, employees or subcontractors; or on account of any negligent act or fault of the Contractor, his agents, employees or subcontractors in the execution of said contract; or on account of the failure of the Contractor to provide the necessary barricades, warning lights or signs; and shall be required to pay any judgment, with cost, which may be obtained against the Owner or Engineer growing out of such injury, including death or damage.





107.14 EQUAL EMPLOYMENT OPPORTUNITY

*DELETE ITEM 107.14.5 REPORTS IN THIS ITEM IN ITS ENTIRETY.*

107.15 STATE AND LOCAL SALES AND USE TAXES

*DELETE IN ITS ENTIRETY AND SUBSTITUTE THEREFORE THE FOLLOWING;*

Recent legislation has removed the sales tax exemption previously provided by Section 151.311 of the Tax Code covering tangible personal property purchased by a contractor for use in the performance of a contract for the improvement of City-owned realty.

It is still possible, however, for a contractor to make tax-free purchases of tangible personal property that will be incorporated into and become part of a City construction project through the use of a "separated contract" with the City. A "separated contract" is one, which separates charges for materials from charges for labor. Under such a contract, the contractor becomes a "seller" of those materials, which are incorporated into the project, such as bricks, lumber, concrete, paint, etc. The contractor issues a resale certificate in lieu of paying the sales tax at the time such items are purchased. The contractor then receives an exemption certificate from the City for those materials (*This procedure may not be used, however, for materials, which do not become a part of the finished product. For example, equipment rentals, form materials, etc. are not considered as becoming "incorporated" into the project*).

Utilization of this "separated contract" approach eliminates the need for bidders to figure in sales tax for materials, which are to be incorporated into the project. Bid items, which contain non-taxable materials, are identified in the Bid Schedule or this project. The successful bidder will be required to complete a Contract Form provided by the Owner identifying and separating non-taxable materials from the labor and taxable materials which are not incorporated into the finished project. The completed contractor form will be used to develop the "separated contract" and will determine the extent of the tax exemption.

107.17 COMPLIANCE WITH LAWS

*ADD THE FOLLOWING SUB ITEM:*

107.17.2 ANTITRUST

The Contractor hereby assigns to the Owner any and all claims for over-charges associated with this contract which arise under the Antitrust Laws of the United States, 15 U.S.C.A. Section 1, et seq., (1973).

*ADD THE FOLLOWING SUB ITEM:*

107.17.3 WAGE RATE

All employees of the Contractor on the work to be performed under this contract shall be paid the prevailing wage scale in this locality for work of a similar character, and in no event less than the rates shown in the Special conditions to the Specifications.

107.20 PROTECTION OF WORK AND PERSONS AND PROPERTY

107.20.2 PROTECTION OF PERSONS AND PROPERTY

*ADD THE FOLLOWING:*

The Contractor shall at all times exercise reasonable precautions for the safety of employees and others on or near the work and shall comply with all applicable provisions of Federal, State, and Municipal Safety laws and building and construction codes. All machinery equipment and other physical hazards shall be guarded in accordance with the "Manual of Accident Prevention in Construction" of the Associated General Contractors of America except where incompatible with Federal, State and Municipal laws or regulations. The Contractor shall provide such machinery,



guards, safe walkways, ladders, bridges, gangplanks and other safety devices. The safety precautions actually taken and their adequacy shall be the sole responsibility of the Contractor, acting at his discretion as an independent contractor.

*ADD THE FOLLOWING SUB ITEM:*

107.20.4 SMALL CLAIMS FOR DAMAGES OR INJURY

If any person files a claim against the OWNER or CONTRACTOR for personal injury or property damage resulting from, arising out of, or caused by the operations of the Contractor, or any work within the limits of the project, the Contractor must either submit to the Owner a duly executed full release within thirty (30) days from the date of written claim, or immediately report the claim to his liability insurance carrier for their action in adjusting the claim. If the Contractor fails to comply with this provision within the stipulated time limit, it will be automatically deemed that the Contractor has appointed the Owner as its irrevocable Attorney in Fact authorizing the Owner to report the claim directly with the liability insurance carrier. This provision is in and of itself a Power of Attorney from the Contractor to the Owner which authorizes the Owner to take said action on behalf of the Contractor without the necessity of the execution of any other document. If the Contractor fails to comply with the provisions of this item the Owner, at its own discretion, may terminate this contract or take any other actions it deems appropriate. Any payment or portion thereof due the Contractor, whether it is a final payment, progress payment, payment out of retainage or refund payment may be withheld by the Owner as is authorized by item 109.4. Bankruptcy, insolvency or denial of liability by the insurance carrier shall not exonerate the Contractor from liability.

ITEM 109 MEASUREMENT AND PAYMENT

109.5 MONTHLY ESTIMATE, PARTIAL PAYMENTS, RETAINAGE, FINAL INSPECTION, ACCEPTANCE AND FINAL PAYMENT

109.5.2 RETAINAGE

*ADD THE FOLLOWING:*

- (4) On projects where the contract price, at the time of execution, is greater than \$400,000.00 the Owner may retain ten (10) percent of the amount due the Contractor, with the retainage above five (5) percent deposited in an interest-bearing account and interest earned on such five (5) percent retained funds shall be paid to the Contractor upon completion of the contract.

109.5.3 FINAL INSPECTION AND ACCEPTANCE

*ADD THE FOLLOWING:*

Within ten (10) days after the Contractor has given the Engineer written notice that the work has been completed, or substantially completed, the Engineer and the Owner shall inspect the work and within said time, if the work be found to be completed or substantially completed in accordance with the Contract Documents, the Engineer shall issue to the Owner and the Contractor his Certificate of Completion, and there upon it shall be the duty of the Owner within ten (10) days to insure a Certificate of acceptance of the work to the Contractor or to advise the Contractor in writing of the reason for non-acceptance.

Definition of Substantially Complete. The date of substantial completion of a project or specified area of a project is the date when the construction is sufficiently completed, in accordance with the contract documents, as modified by any change order agreed to by the parties, so that the Owner can occupy or utilize the project or specified area of the project for the use for which it was intended.



**SECTION 7.02 | DIVISION 200. SITE PROTECTION AND PREPERATION**

*NOTE:* THE (1) SYMBOL SPECIFIES THAT THIS ITEM IS ALSO COVERED IN THE CITY OF ROCKWALL'S "SPECIAL PROVISIONS" TO THE "STANDARD SPECIFICATIONS FOR PUBLIC WORKS CONSTRUCTION, NORTH CENTRAL TEXAS". THESE SPECIAL PROVISIONS ARE ADDITIONAL AND MODIFY THE "STANDARD SPECIFICATION"

**TABLE 7.2: REVISIONS TO NCTCOG'S DIVISION 200 SITE PROTECTION AND PREPARATION**

REVISED	STANDARD SPECIFICATION ITEM NO.	DESCRIPTION
	<b>201</b>	<b>SITE PROTECTION</b>
	201.1	REMOVAL, PROTECTION, AND REPLACEMENT OF TREES, SHRUBBERY, PLANTS, SOD AND OTHER VEGETATION
	201.2	DETERMINING LOCATION AND PROTECTION OF EXISTING STRUCTURES AND UTILITIES
	201.3	MAINTENANCE OF STREETS AND RIGHTS OF WAY DURING CONSTRUCTION
	<b>202</b>	<b>TEMPORARY EROSION, SEDIMENTATION, AND WATER POLLUTION PREVENTION AND CONTROL</b>
	202.1	DESCRIPTION
	202.2	ITEMS OF WORK AND MATERIALS
	202.3	PRE-CONSTRUCTION SUBMITTALS
	202.4	CONSTRUCTION REQUIREMENTS
(1)	202.5	SILT FENCE
	202.6	INTERCEPTOR SWALE
	202.7	DIVERSION DIKE
	202.8	TRIANGULAR SEDIMENT FILTER DIKE
	202.9	CHECK DAM (ROCK)
	202.10	CHECK DAM (FILTER TUBE)
(1)	202.11	STABILIZED CONSTRUCTION EXIT
	202.12	STOP OUTLET SEDIMENT TRAP
	202.13	PIPE SLOPE DRAIN
	202.14	INLET PROTECTION
	202.15	EROSION CONTROL BLANKETS
	202.16	SECTION HELD FOR FUTURE USE
	202.17	SECTION HELD FOR FUTURE USE
	202.18	FILTER TUBES
	202.19	MEASUREMENT AND PAYMENT
	<b>203</b>	<b>SITE PREPARATION</b>
	203.1	GENERAL SITE PREPARATION
(1)	203.2	UNCLASSIFIED STREET EXCAVATION
	203.3	SECTION HELD FOR FUTURE USE
	203.4	BORROW & SPOIL
(1)	203.5	EMBANKMENT
	203.6	DUST CONTROL
	<b>204</b>	<b>LANDSCAPING</b>
	204.1	REMOVAL, PROTECTION, AND REPLACEMENT OF TREES, SHRUBBERY, PLANTS, SOD AND OTHER VEGETATION
(1)	204.2	TOPSOIL
	204.3	SOIL AMENDMENTS
	204.4	FERTILIZER
	204.5	SODDING
(1)	204.6	SEEDING TURF-GRASS
	204.7	REJECTION

**ITEM 201 TEMPORARY EROSION, SEDIMENTATION, AND WATER POLLUTION PREVENTION AND CONTROL**

**202.5. SILT FENCE**



202.5.2. MATERIALS

202.5.2.2. POSTS

*DELETE THE LAST SENTENCE IN ITS ENTIRETY AND REPLACE WITH THE FOLLOWING:*

No wood stakes shall be allowed.

202.11. STABILIZED CONSTRUCTION EXIT

202.11.2. MATERIALS

202.11.2.1 STONE

*DELETE THE FOLLOWING SUBSECTION IN ITS ENTIRETY AND REPLACE WITH THE FOLLOWING:*

Stone material shall consist of four (4) to six (6) inch minimum course aggregate riprap and shall be place in a layer 12-inch thick. No crushed or recycled concrete shall be allowed.

ITEM 203 SITE PREPERATION

203.2. UNCLASSIFIED STREET EXCAVATION

203.2.3. GENERAL

*ADD TO THE FOLLOWING AS THE THIRD PARAGRAPH:*

Unless otherwise approved in writing by the City of Rockwall, where excavation to grade established in the field by the Owner terminates in loose or solid rock, the Contractor shall excavate six (6) inches below the required subgrade elevations for the entire roadbed width and shall backfill with suitable selected materials as indicated on the plans. Suitable selected material shall include lime treated subgrade or a base material having a plasticity index not greater than 12. Payment for such work will be made under the items of unclassified street excavation, lime treated subgrade and hydrated lime. The six (6) inch lime treated subgrade or base shall be compacted to 95 percent standard proctor density.

ITEM 204 LANDSCAPING

204.2. TOPSOIL

204.2.3. CONSTRUCTION METHODS

*ADD THE FOLLOWING:*

A minimum of four (4) inches of topsoil shall be provided on all major thoroughfare medians and rights-of-way and on all earthen channel slopes to the lines and grades established by the construction plans. This will be material imported from off site. The City will approve material prior to placement.

204.6 SEEDING TURFGRASS

204.6.1. GENERAL

*ADD THE FOLLOWING:*



The Contractor shall maintain the seeded areas including watering until a “Stand of Grass” is obtained. A “Permanent Stand of Grass” shall consist of 75 percent to 80 percent coverage, a minimum of one (1) inch in height. Re-seeding will be required in washed areas.

### 204.6.3. PLANTING SEASON AND APPLICATION RATE

*DELETE THE MIXTURE, RATE, AND PLANTING DATES IN TABLE 204.6.3.(A) SEEDING TURFGRASS AND SUBSTITUTE:*

TYPE NO.	VARIETY	HULLED OR UNHULLED	WEIGHT/ACRE	PLANTING SEASON
TYPE I	BERMUDA GRASS	HULLED	50 LBS/ACRE	APRIL THROUGH JUNE
TYPE II	ANNUAL RYE GRASS	N/A	40 LBS/ACRE	SEPTEMBER THROUGH MARCH
TYPE III	BERMUDA GRASS	UNHULLED	50 LBS/ACRE	JANUARY THROUGH MARCH & JULY THROUGH AUGUST

**NOTE:** A mix of seed shall be used in overlapping seasons.

## SECTION 7.03 | DIVISION 300. ROADWAY CONSTRUCTION

**NOTE:** THE (1) SYMBOL SPECIFIES THAT THIS ITEM IS ALSO COVERED IN THE CITY OF ROCKWALL’S “SPECIAL PROVISIONS” TO THE “STANDARD SPECIFICATIONS FOR PUBLIC WORKS CONSTRUCTION, NORTH CENTRAL TEXAS”. THESE SPECIAL PROVISIONS ARE ADDITIONAL AND MODIFY THE “STANDARD SPECIFICATION”

### TABLE 7.3: REVISIONS TO NCTCOG’S DIVISION 300 ROADWAY CONSTRUCTION

REVISED	STANDARD SPECIFICATION ITEM NO.	DESCRIPTION
	<b>301</b>	<b>SUBGRADE, SUBBASE AND BASE PREPARATION</b>
	301.1	GENERAL
(1)	301.2	LIME TREATMENT
(1)	301.3	PORTLAND CEMENT TREATMENT
	301.4	ASPHALT EMULSION TREATMENT
(1)	301.5	FLEXIBLE SUB-BASE OR BASE (CRUSHED STONE/CONCRETE)
	301.6	GEO-TEXTILES USED IN PAVING APPLICATIONS
	<b>302</b>	<b>ASPHALT PAVEMENT</b>
	302.1	DESCRIPTION
	302.2	AGGREGATES FOR HOT-MIX ASPHALT PAVEMENT
	302.3	BITUMINOUS MATERIALS
	302.4	SECTION HELD FOR FUTURE USE
	302.5	STORAGE, HEATING AND APPLICATION TEMPERATURE OF BITUMINOUS MATERIALS
	302.6	EMULSIFIED ASPHALT TREATMENT
	302.7	PRIME COAT
	302.8	ASPHALT BASE COURSE
	302.9	HOT-MIX ASPHALT PAVEMENT
	302.10	MEASUREMENT AND PAYMENT
	<b>303</b>	<b>PORTLAND CEMENT CONCRETE PAVEMENT</b>
	303.1	DESCRIPTION
(1)	303.2	PORTLAND CEMENT CONCRETE PAVEMENT MATERIALS
(1)	303.3	MIX DESIGN AND MIXING CONCRETE
	303.4	EQUIPMENT
(1)	303.5	CONSTRUCTION METHODS
	303.6	ALLEY PAVING



	303.7	PAVEMENT LEAVE-OUTS
(1)	303.8	PAVEMENT TESTING AND EVALUATION
	303.9	MEASUREMENT AND PAYMENT
<hr/>		
	<b>304</b>	<b>PAVING UNITS</b>
(1)	304.1	SOLID CONCRETE INTERLOCKING PAVING UNITS
<hr/>		
	<b>305</b>	<b>MISCELLANEOUS ROADWAY CONSTRUCTION</b>
(1)	305.1	CONCRETE CURB AND GUTTER
(1)	305.2	CONCRETE SIDEWALKS, DRIVEWAY APPROACHES, AND BARRIER FREE RAMPS
(1)	305.3	CONCRETE MEDIANS
	305.4	REINFORCED CONCRETE HEADERS

**ITEM 301. SUBGRADE, SUBBASE AND BASE PREPERATION**

**301.2 LIME TREATMENT**

*ADD THE FOLLOWING SENTENCES:*

Quick Lime shall not be used in the construction of roadway work in the City. Dry hydrated lime shall not be used for treating subgrade or base material unless specified on the plans

**301.2.1. MATERIALS**

**301.2.1.2. QUICKLIME**

**301.2.1.2.1. GENERAL**

*ADD TO THE BEGINNING OF THE FIRST PARAGRAPH:*

Quicklime (dry) shall not be used in the City without written approval from the City.

**301.2.3. LIME TREATMENT CONSTRUCTION METHODS**

**301.2.3.3. GENERAL CONSTRUCTION**

**301.2.3.3.1. TREATMENT FOR MATERIALS IN PLACE**

*ADD THE FOLLOWING:*

Prior to final compaction of subgrade, samples of the subgrade material shall be collected by a testing laboratory approved by the City, and laboratory tests made to determine the amount of lime required.

The application rate for hydrated lime shall be selected to obtain at least the optimum lime percentage indicated by test method *ASTM C977-83a, Appendix XI*; however, not less than 27 LBS per SY shall be applied. A Geotechnical Engineer’s report reflecting the recommended application rate and including supporting test data shall be submitted in writing to the City, for approval prior to beginning any lime treatment. Laboratory test may be waived provided a minimum of 36 LBS per SY is applied. Testing shall look for sulfates to see if *Lime Treatment* will cause and adverse effect on the subgrade.

**301.2.3.7. MAINTENANCE**



*ADD THE FOLLOWING TO THE FIRST PARAGRAPH:*

The lime treated subgrade shall be moist cured until covered by other base or pavement up to 14-days after final compaction. After 14-days without covering an application of 0.10 to 0.20 gallons per square yard emulsified asphalt shall be applied at the Contractor's expense. Reapplication of emulsified asphalt may be required if lime treated subgrade is not covered shortly after first application. Lime treated subgrade may be covered by other base or pavement when density of 95 percent of maximum at optimum moisture content is obtained.

301.3 PORTLAND CEMENT TREATMENT

*ADD THE FOLLOWING:*

Portland cement modification of subgrade soils is not approved in Rockwall. Subgrade soils means natural ground or embankment encountered in the construction.

301.5 FLEXIBLE SUBBASE OR BASE (CRUSHED STONE/CONCRETE)

301.5.1. MATERIAL

301.5.1.1. GENERAL

*ADD THE SENTENCE:*

No local limestone material shall be used as flexible base (crushed limestone) on Rockwall paving projects, unless otherwise shown on the plans.

301.5.1.2 TESTS AND PHYSICAL REQUIREMENTS

*AFTER THE FIRST SENTENCE ADD THE SENTENCE:*

Samples of crushed limestone shall be submitted to the engineer testing laboratory employed by the City for testing and conformance with the specifications.

ITEM 303 PORTLAND CEMENT PAVEMENT

303.2. PORTLAND CEMENT CONCRETE PAVEMENT MATERIALS

303.2.1. AGGREGATES FOR PORTLAND CEMENT CONCRETE

303.2.1.3. COARSE AGGREGATES

Gradation:

*ADD THE SENTENCE:*

For Rockwall paving projects, the coarse aggregate's gradation shall meet the requirements of Size No. 4 shown in the table.

303.3 MIX DESIGN AND MIXING CONCRETE FOR PAVEMENT

303.3.5. MIXING AND DELIVERY

303.3.5.3. CENTRAL MIXING PLANT



*ADD THE FOLLOWING:*

When a fly ash admixture is used with Type I cement in the production of Portland cement concrete, separate silos shall be provided for fly ash and cement and provisions shall be made for individual measurements.

303.5 CONSTRUCTION METHODS

303.5.6. FINISHING

*DELETE 303.5.6. AND ADD THE FOLLOWING:*

The finished concrete pavement construction under these specifications is expected to meet certain quality standards for surface of the concrete including the durability, texture, riding surface and appearance. The surface must be durable, firm, dense and well bonded to the aggregate to maintain an appearance and texture which is satisfactory to the Owner. Concrete pavement having a poor surface which has spalled (*exposed aggregate*) due to poor quality paste, high water-cement ratio, over-vibration, improper curing, extreme weather or any other reason, or does not have a satisfactory riding surface shall be removed and replaced at the Contractor's expense. It is extremely important that the pavement have a good rideable surface, free from undulations and rough joints. The City Engineer shall determine the acceptability of the pavement.

303.5.6.1. MACHINE FINISHING

Machine finishing of pavement shall include the use of power-driven spreaders, reciprocating type power-driven vibrators, power-driven transverse strike-off, and screed.

The concrete pavement shall be consolidated by a reciprocating type mechanical vibrator. As soon as the concrete has been spread between the forms, the mechanical vibrator shall be operated to consolidate the concrete and remove all voids. Hand manipulated vibrators shall be used for areas not covered by the mechanical vibratory unit.

The transverse finishing machine shall first be operated to compact and finish the pavement to the required section and grade, without surface voids. The machine shall be operated over each area as many times and at such intervals as directed. At least two trips will be required and the last trip over a given area shall be a continuous run of not less than 40-feet. After completion of finishing with the transverse finishing machine a transverse drag float may be used.

After the floating has been completed and the excess water removed, but while the concrete is still plastic, the surface of the concrete shall be tested for trueness with an approved ten (10) foot steel straightedge furnished by the Contractor. The straightedge shall be operated from the side of the pavement, placed parallel to the pavement centerline and passed across the slab to reveal any high spots or depressions. The straightedge shall be advanced along the pavement in successive stages of not more than one-half its length. Practically perfect contact of the straightedge with surface will be required, and the pavement shall be leveled to this condition, in order to insure conformity with the surface test required below after the pavement has fully hardened and to insure a smooth rideable surface. Any correction of the surface required shall be accomplished by adding concrete if required and by operating the longitudinal float over the area. The surface test with the straightedge shall then be repeated.

After completion of the straightedge testing and surface correction the surface of the pavement shall be finished by an approved method. Methods available for pavement surface finish including a burlap drag finish, a broom finish or a belt finish. Unless otherwise shown on the plans, the pavement surface shall be finished with the burlap drag.

303.5.6.1.1. BURLAP DRAG FINISH





If the surface texture is to be a drag finish, a drag shall be used; it shall consist of a seamless strip of damp burlap or cotton fabric, and it shall produce a uniform surface of gritty texture after dragging it longitudinally along the full width of pavement. For pavement 16-feet or more in width, the drag shall be mounted on a bridge which travels on the forms. The diameter of the drag shall be such that a strip of burlap or fabric at least three (3) feet wide is in contact with the full width of pavement surface while the drag is used. The drag shall consist of not less than two layers of burlap with the bottom layer approximately six (6) inches wider than the upper layer. The drag shall be maintained in such a condition that the resultant surface is of uniform appearance and reasonably free from gravels over 1/16-inch in depth. Drags shall be maintained clean and free from encrusted mortar. Drags that cannot be cleaned shall be discarded and new drags substituted.

#### 303.5.6.1.2. BROOM FINISH

If the surface texture is to be broom finished, it shall be applied when the water sheen has practically disappeared. The broom shall be drawn from the center to the edge of the pavement with adjacent strokes slightly overlapping. The broom operation shall be so executed that the corrugation produced in the surface shall be uniform in appearance and not more than 1/16-inch in depth. Brooming shall be completed before the concrete is in such condition that the surface will be torn or unduly roughened by the operation. The surface thus finished shall be free from rough and porous areas, irregularities, and depressions resulting from improper handling of the broom. Brooms shall be of the quality, size, and construction and shall be operated to produce a surface finish meeting the approval of the Owner. Subject to the approval of the Owner, the Contractor may be permitted to substitute mechanical brooming in lieu of the manual brooming as herein described.

#### 303.5.6.1.3. BELT FINISH

If the surface texture is to be belt finish, when straightedging is completed and after sheen has practically disappeared and just before the concrete becomes non-plastic, the surface shall be belted with a two (2) ply canvas belt not less than eight (8) inches wide and at least three (3) feet longer than the pavement width. Hand belts shall have suitable handles to permit controlled, uniform manipulation. The belt shall be operated with short strokes transverse to the centerline and with a rapid advance parallel to the centerline.

#### 303.5.6.2. HAND FINISHING

Hand finishing of concrete pavement will be permitted in areas where it is not practical or possible to construct with finishing machines. These areas include, but are not limited to, intersections, left turn lanes, crossovers, transition areas and where the pavement width is not uniform. In all hand finished areas, one-half (1/2) extra sack of cement per cubic yard of concrete shall be used in the mix. In hand finished areas, the concrete shall be struck off with an approved strike-off screed to such elevation that when consolidated and finished the surface of the pavement shall conform to the required section and grade. The strike template shall be moved forward with a combined transverse and longitudinal motion in the direction the work is progressing, maintaining a slight excess of material in front of the cutting edge. The concrete shall then be tamped with an approved tamping template to compact the concrete thoroughly and eliminate surface voids and the surface screeded to required section. After completion of a strike-off, consolidation and transverse screeding, a hand-operated longitudinal float shall be operated to test and level the surface to the required grade.



Workmen shall operate the float from approved bridges riding on the forms and spanning the pavement. The longitudinal float shall be held in contact with the surface and parallel to the centerline and operated with short longitudinal strokes while being passed from one side of the pavement to the other. If contact with the pavement is not made at all points, additional concrete shall be placed, if required, and screeded, and the float shall be used to produce a satisfactory surface. Care shall be exercised to keep the ends of the float from digging into the surface of the pavement. After a section has been smoothed so that the float maintains contact with the surface at all points in being passed from one side to the other, the bridges may be moved forward half the length of the float and the operation repeated. Other operations and surfaces tests shall be as required for machine finishing.

### 303.5.6.3. EDGING AT FORMS AND JOINTS

After the final finish, but before the concrete has taken its initial set, the edges of the pavement along each side of each slab, and on each side of transverse expansion joints, formed joints, transverse construction joints, and emergency construction joints shall be worked with an approved tool and rounded to the radius required by the plans. A well-defined and continuous radius shall be produced and a smooth, dense mortar finish obtained. The surface of the slab shall not be unduly disturbed by tilting of the tool during use.

At all joints, any tool marks appearing on the slab adjacent to the joints shall be eliminated by brooming the surface. In doing this, the rounding of the edge shall not be disturbed. All concrete on top of the joint filler shall be completely removed.

All joints shall be tested with a straightedge before the concrete has set, and correction shall be made if one side of the joint is higher than the other or if they are higher or lower than the adjacent slabs.

## 303.8 PAVEMENT TESTING AND ELEVATION

### 303.8.2. PAVEMENT THICKNESS TEST

*DELETE IN ITS ENTIRETY AND SUBSTITUTE THEREFORE THE FOLLOWING:*

Upon completion of the work and before final acceptance and final payment shall be made, pavement thickness tests shall be made by the Contractor. Tests shall be made at 400-foot spacings along the length of the pavement. In the event a deficiency in the thickness of pavement is revealed, two (2) subsequent sets necessary to isolate the deficiency shall be made - one at a jointed section prior to the deficient station and one at a jointed section following the deficient station. Additional tests shall be obtained as necessary, at jointed section intervals to isolate the deficient area. Removal and replacement of concrete shall extend to joint boundaries, the full width of pavement section. If the average thickness of pavement in a particular section is less than called for on the plans, the pavement section shall be removed and replaced with the correct thickness, extending to joint boundaries, the full width of the pavement section, at the Contractor's entire expense. No additional payment over the contract unit price shall be made for any pavement of a thickness exceeding that required on the plans.

### 303.8.3. PAVEMENT STRENGTH TEST

#### 303.8.3.1 FOR STANDARD CLASSES OF CONCRETE

*REVISE THE FIRST PARAGRAPH TO READ:*

During the progress of the work, the Inspector or a commercial laboratory shall cast test cylinders or beams to maintain a check on the strengths of the concrete being placed. Add the following sentence and table: A table titled "PAVEMENT STRENGTH REQUIREMENTS", is provided showing the required pavement thickness, seven (7) day strength, fourteen (14) day strength, 2-28-day strength (no averaging), minimum cement factor and maximum slump for each street type to be constructed in Rockwall.



**ADD TO THE 5TH PARAGRAPH:**

Test cores shall be obtained within ten (10) working days after the 28-day test results have been provided by the commercial laboratory. All test cores shall be obtained by a commercial laboratory, at the Contractors expense. One (1) core shall be obtained in the immediate area of the deficiency and two (2) additional cores shall be obtained - one at a jointed section prior to the deficient station and one at a jointed section following the deficient station. Additional cores shall be obtained as necessary, at jointed section intervals to isolate the deficient area. Removal and replacement of concrete shall extend to joint boundaries, the full width of pavement section.

**AMEND THE SECOND SENTENCE OF THE 7TH PARAGRAPH TO READ:**

“Pavement not meeting the minimum specified 28-day strength after cores have been tested shall be removed and replaced at the Contractor’s expense.”

**DELETE THE TABLE 303.8.3.1(A) AND THE PARAGRAPH BELOW IT.**

**ADD THE FOLLOWING TABLE:**

**TABLE: PAVEMENT STRENGTH REQUIREMENTS**

STREET/PAVEMENT TYPE	MINIMUM THICKNESS (INCHES)	STRENGTH 28-DAY (PSI)	MINIMUM CEMENT (SACKS / CY)		STEEL REINFORCEMENT		SLUMP (INCHES)
			MACHINE PLACED	HAND PLACED	BAR #	SPACING (O.C.E.W.)	
ARTERIAL <sup>1</sup>	10"	3,600	6.0	6.5	#4 BARS	18"	3"-5"
COLLECTOR <sup>1</sup>	8"	3,600	6.0	6.5	#4 BARS	18"	3"-5"
RESIDENTIAL	6"	3,600	6.0	6.5	#3 BARS	24"	3"-5"
ALLEY	7"-5"-7"	3,600	6.0	6.5	#3 BARS	24"	3"-5"
FIRE LANE	6"	3,600	6.0	6.5	#3 BARS	24"	3"-5"
DRIVEWAYS	6"	3,600	6.0	6.5	#3 BARS	24"	3"-5"
<b>DRIVEWAY APPROACHES WITHIN ROW</b>			<b>TO MATCH DESIGN OF STREET PAVEMENT TYPE CONNECTING INTO</b>				
BARRIER FREE RAMPS	6"	3,600	N/A	6.5	#3 BARS	24"	3"-5"
SIDEWALKS	4"	3,000	N/A	5.5	#3 BARS	24"	3"-5"
TRAILS	6"	3,600	N/A	6.5	#3 BARS	24"	3"-5"
PARKING LOT/DRIVE AISLES	5"	3,000	5.0	5.5	#3 BARS	24"	3"-5"
DUMPSTER PADS	7"	3,600	6.0	6.5	#3 BARS	24"	3"-5"

**NOTES:**

<sup>1</sup>: PAVING SECTION DESIGNS FOR ARTERIALS AND COLLECTORS SHALL BE BASED OFF 30-YEAR PROJECTED TRAFFIC VOLUMES AND GEOTECHNICAL ANALYSIS/REPORT (PAVING SECTION DESIGN SHALL INCLUDE BUT NOT LIMITED TO THE FOLLOWING: PAVEMENT THICKNESS, REINFORCING SIZE AND SPACING, PAVEMENT STRENGTH, SUBGRADE THICKNESS, SUBGRADE TREATMENT TYPE [LIME OR CEMENT]).

**ITEM 304 PAVING UNITS**

304.1. SOLID CONCRETE INTERLOCKING PAVING UNITS

304.1.2. MATERIALS

304.1.2.2. BASE

**DELETE IN ITS ENTIRETY AND REPLACE WITH THE FOLLOWING:**



The base shall be constructed of 3,600 PSI reinforced concrete meeting the requirements of Item 303 of the Standard Specifications. #4 reinforcing bars shall be placed 18-inches on center, both ways, in all concrete.

304.1.3. CONSTRUCTION METHODS

304.1.3.3. CONSTRUCTION PROCEDURES

304.1.3.3.3 PAVING UNITS AND JOINTS

*DELETE PARAGRAPH TWO IN ITS ENTIRETY AND REPLACE WITH THE FOLLOWING:*

Joints between paving units shall have a spacing of  $\frac{1}{8}$ -inch.

304.1.4. MEASUREMENT AND PAYMENT

*DELETE IN ITS ENTIRETY AND REPLACE WITH THE FOLLOWING:*

Interlocking Concrete Paving Stone shall be measured and paid for by the square foot of stone, sand and concrete base furnished and installed, which price shall include all labor, including excavation, materials, equipment, tools and incidentals necessary to complete the work. No separate payment shall be made for six (6) inch concrete base or washed sand. Payment for removal and disposal of existing concrete median pavement, if required, shall be made by the square foot. Payment shall include all labor, equipment, materials, tools, and incidentals necessary to complete the work.

ITEM 305. MISCELLANEOUS ROADWAY CONSTRUCTION

305.1. CONCRETE CURB AND GUTTER

305.1.3. CONSTRUCTION METHODS

305.1.3.2. REINFORCING STEEL

*THE THIRD SENTENCE, FIRST PARAGRAPH SHALL BE REVISED TO READ:*

All bars at splices shall be lapped a minimum of 30 diameters of the bar or 12-inches, whichever is greater.

305.2. CONCRETE SIDEWALKS, DRIVEWAY APPROACHES, AND BARRIER FREE RAMPS

305.2.2. MATERIALS

305.2.2.2. REINFORCEMENT

*REVISE THE FIRST SENTENCE TO READ:*

Driveway approaches and walk reinforcing shall be No. 3 bars on 24-inch centers.

305.2.3. CONSTRUCTION METHODS

305.2.3.1. GENERAL

*ADD TO END OF FIRST PARAGRAPH:*



The drive approach shall have a minimum thickness equal to the thickness of the adjacent street or six (6) inches, whichever is greater.

305.2.3.7. JOINTS

*REVISE SECOND SENTENCE TO READ:*

Expansion joints shall be placed in the sidewalk at 20-foot intervals or as otherwise specified by the Owner.

305.3. CONCRETE MEDIANS

*DELETE IN ENTIRETY.*

**SECTION 7.04 | DIVISION 400. ROADWAY MAINTENANCE AND REHABILITATION**

*NOTE:* THE (1) SYMBOL SPECIFIES THAT THIS ITEM IS ALSO COVERED IN THE CITY OF ROCKWALL'S "SPECIAL PROVISIONS" TO THE "STANDARD SPECIFICATIONS FOR PUBLIC WORKS CONSTRUCTION, NORTH CENTRAL TEXAS". THESE SPECIAL PROVISIONS ARE ADDITIONAL AND MODIFY THE "STANDARD SPECIFICATION"

**TABLE 7.4: REVISIONS TO NCTCOG'S DIVISION 400 ROADWAY MAINTENANCE AND REHABILITATION**

REVISED	STANDARD SPECIFICATION ITEM NO.	DESCRIPTION
	<b>401</b>	<b>CRACK SEALING</b>
	401.1	GENERAL
	401.2	MATERIALS
	401.3	METHODS
	401.	MEASUREMENT AND PAYMENT
	<b>402</b>	<b>PAVEMENT CUT, EXCAVATION AND REPAIR</b>
	402.1	GENERAL REQUIREMENTS
	402.2	MINIMUM SIZE OF REPAIR
(1)	402.3	SAWING
	402.4	REPLACING PAVED SURFACES
	<b>403</b>	<b>ASPHALTIC PAVEMENT REPAIR</b>
	403.1	DESCRIPTION
	403.2	MATERIALS AND MIXING
	403.3	METHODS
	403.4	MEASUREMENT AND PAYMENT
	<b>404</b>	<b>SURFACE TREATMENT</b>
	404.1	DESCRIPTION
	404.2	GENERAL
	404.3	SLURRY SEALS AND MICRO-(RE)SURFACING
	404.4	BITUMINOUS SURFACE TREATMENT (CHIP SEAL)
	<b>405</b>	<b>ULTRA THIN CONCRETE PAVING (WHITETOPPING)</b>
	405.1	DESCRIPTION
	405.2	MATERIALS
	405.3	CONSTRUCTION METHODS
	405.4	MEASUREMENTS
	405.5	PAYMENT

**ITEM 402 PAVEMENT CUT, EXCAVATION AND REPAIR**

402.3 SAWING



402.3.2. EQUIPMENT

*REVISE SECOND PARAGRAPH TO READ:*

Saw blades shall make a clean, smooth cut, producing a groove a minimum of 3/8-inch wide and to the full depth required by these specifications or as shown on the plans.

**SECTION 7.05 | DIVISION 500. UNDERGROUND CONSTRUCTION AND APPURTENANCES**

*NOTE:* THE (1) SYMBOL SPECIFIES THAT THIS ITEM IS ALSO COVERED IN THE CITY OF ROCKWALL'S "SPECIAL PROVISIONS" TO THE "STANDARD SPECIFICATIONS FOR PUBLIC WORKS CONSTRUCTION, NORTH CENTRAL TEXAS". THESE SPECIAL PROVISIONS ARE ADDITIONAL AND MODIFY THE "STANDARD SPECIFICATION"

**TABLE 7.5: REVISIONS TO NCTCOG'S DIVISION 500 UNDERGROUND CONSTRUCTION AND APPURTENANCES**

REVISED	STANDARD SPECIFICATION ITEM NO.	DESCRIPTION
	<b>501</b>	<b>UNDERGROUND CONDUIT MATERIALS</b>
	501.1	GENERAL
	501.2	CLAY WASTEWATER PIPE
	501.3	VITRIFIED CLAY PIPE FOR MICRO-TUNNELING, SLIP-LINING, PIPE BURSTING AND TUNNELS
(1)	501.4	CONCRETE PRESSURE PIPE AND FITTINGS
(1)	501.5	REINFORCED CONCRETE WASTEWATER PIPE WITH RUBBER GASKET JOINTS
	501.6	REINFORCED CONCRETE CULVERT, STORM DRAIN, PIPE AND BOX SECTION
(1)	501.7	DUCTILE-IRON PRESSURE PIPE AND FITTINGS
	501.8	DUCTILE-IRON PIPE FOR PIPE REHABILITATION
(1)	501.9	STEEL PIPE AND FITTINGS
	501.10	SEAMLESS COPPER TUBING
	501.11	CORRUGATED METAL PIPE OR ARCH SHAPES
	501.12	STRUCTURAL PLATE STRUCTURES
	501.13	TUNNEL LINER PLATES
(1)	501.14	POLYVINYL CHLORIDE (PVC) WATER PIPE
	501.15	POLYVINYL CHLORIDE (PVC) PRESSURE-RATED (SDR SERIES)
	501.16	MOLECULARLY ORIENTED POLYVINYL CHLORIDE (PVCO) WATER PIPE
	501.17	POLYVINYL CHLORIDE (PVC) WASTEWATER PIPE & FITTINGS WITH DIMENSION CONTROL
	501.18	POLYVINYL CHLORIDE (PVC) PROFILE GRAVITY WASTEWATER PIPE AND FITTINGS-FOR DIRECT BURY AND SLIP-LINING APPLICATIONS
	501.19	PVC COMPOSITE PIPE FOR WASTEWATER CONDUITS
	501.20	POLYVINYL CHLORIDE (PVC) CORRUGATED STORM WATER PIPE WITH SMOOTH INTERIOR AND FITTINGS
	501.21	SOLID WALL POLYETHYLENE PLASTIC PIPE FOR WATER, WASTEWATER AND PIPE REHABILITATION
	501.22	POLYETHYLENE (PE) LARGE DIAMETER WASTEWATER PIPE WITH MODIFIED WALL PROFILES AND PERFORMANCE STANDARDS
	501.23	POLYETHYLENE (PE) CORRUGATED DRAINAGE TUBING AND CORRUGATED SMOOTH LINED STORM WATER PIPE AND FITTINGS
	501.24	FIBERGLASS (GLASS-FIBER-REINFORCED THERMOSETTING-RESIN) WASTEWATER PIPE
	501.25	FIBERGLASS (GLASS-FIBER-REINFORCED THERMOSETTING-RESIN) WATER PIPE
	<b>502</b>	<b>APPURTENANCES</b>
(1)	502.1	MANHOLES
	502.2	WASTEWATER MAIN CLEANOUTS
(1)	502.3	FIRE HYDRANTS
	502.4	THRUST RESTRAINT
(1)	502.5	FITTINGS
(1)	502.6	VALVES
	502.7	PERFORMED FLEXIBLE CONDUIT JOINT SEALANT



	502.8	POLYETHYLENE WRAP FOR METAL PIPE FITTINGS
	502.9	CORROSION-RESISTANT COATINGS AND LINERS FOR WASTEWATER CONDUIT AND APPURTENANCES
	502.10	CONNECTIONS TO CONDUIT FOR SERVICE
	502.11	MISCELLANEOUS CONDUIT CONNECTIONS
	502.12	STRUCTURES
	<b>503</b>	<b>TRENCHLESS INSTALLATION</b>
	503.1	CONDUIT MATERIALS
	503.2	TUNNEL/CHASING PIPE SPACERS
	503.3	METHODS OF JACKING, BORING OR TUNNELING
	503.4	MEASUREMENT AND PAYMENT
	<b>504</b>	<b>OPEN CUT - BACKFILL</b>
	504.1	GENERAL
(1)	504.2	MATERIALS
(1)	504.3	EXCAVATION AND FOUNDATION
(1)	504.4	BACKFILL-GENERAL REQUIREMENTS
(1)	504.5	EMBEDMENT
(1)	504.6	FINAL BACKFILL
	504.7	MEASUREMENT AND PAYMENT OF BACKFILL
	<b>505</b>	<b>OPEN CUT – GENERAL CONDUIT INSTALLATION</b>
	505.1	GENERAL
	505.2	GENERAL INSTALLATION REQUIREMENTS FOR PIPE TYPES
	<b>506</b>	<b>OPEN CUT – WATER CONDUIT INSTALLATION</b>
	506.1	DESCRIPTION
	506.2	MATERIALS
(1)	506.3	LAYING WATER CONDUIT
	506.4	PIPE JOINTS
(1)	506.5	HYDROSTATIC TEST
	506.6	CONNECTIONS TO EXISTING WATER CONDUITS
	506.7	PURGING AND DISINFECTION OF WATER CONDUITS
	506.8	PLUGS
	506.9	MEASUREMENTS AND PAYMENTS
	<b>507</b>	<b>OPEN CUT- WASTEWATER CONDUIT INSTALLATION</b>
	507.1	DESCRIPTION
	507.2	MATERIALS
	507.3	LAYING WASTEWATER CONDUIT
	507.4	WASTEWATER CONDUIT JOINTS
(1)	507.5	TEST AND INSPECTIONS
	507.6	MEASUREMENT AND PAYMENT FOR WASTEWATER CONDUIT INSTALLATION
	<b>508</b>	<b>OPEN CUT – STORM WATER CONDUIT INSTALLATION</b>
	508.1	DESCRIPTION
	508.2	GENERAL
	508.3	REINFORCED CONCRETE PIPE FOR STORM WATER
	508.4	CORRUGATED METAL PIPE
	508.5	STRUCTURAL PLATE CONDUIT
	508.6	MEASUREMENT AND PAYMENT FOR STROM WATER CONDUIT INSTALLATION
(1)	508.7	STORM SEWER CONDUIT INSPECTION
	<b>509</b>	<b>CROSSINGS</b>
	509.1	GENERAL



	509.2	STATE HIGHWAY CROSSINGS
	509.3	STREET AND ALLEY CROSSINGS
	509.4	RAILROAD CROSSING
(1)	509.5	CREEK AND RIVER CROSSINGS
	509.6	MEASUREMENT AND PAYMENT OF CROSSINGS

### ITEM 501. UNDERGROUND CONDUIT MATERIALS

#### 501.4 CONCRETE PRESSURE PIPE AND FITTINGS

##### *ADD THE FOLLOWING:*

C302 Reinforced Concrete Pressure Pipe, Non-Cylinder Type, for Water and Other Liquids, and C300 Reinforced Concrete Pressure Pipe, Steel Cylinder Type, for Water and Other Liquids are not approved for use in the City, unless otherwise shown in the plans or approved in writing. Reinforced concrete cylinder pipe in sizes 16-inches through 21-inches shall be Bar-Wrapped Concrete Cylinder Pipe AWWA Type C303. For pipe 42-inches in diameter and above the pipe shall be Prestressed Concrete Pressure Pipe, Steel Cylinder Type, AWWA Type C301. Between 24-inches and 36-inches the pipe furnished may be either type. All pipe shall be designed to withstand the working pressure and external load as shown in the plans.

#### 501.5 REINFORCED CONCRETE WASTEWATER PIPE WITH RUBBER GASKET JOINTS

##### 501.5.1. GENERAL

##### *ADD THE FOLLOWING:*

All reinforced concrete pipe used in the sanitary sewer system shall conform to ASTM Designation C76 and shall be of the Thick Wall Pipe design with aggregates consisting of limestone aggregate in the proportion of at least 75 percent by weight of the total aggregates, unless otherwise provided in the *Special Conditions to the Specifications*.

#### 501.7 DUCTILE-IRON PRESSURE PIPE AND FITTINGS

##### 501.7.1. GENERAL

##### *ADD THE FOLLOWING:*

Minimum design thickness for all Ductile-Iron Pipe installed shall be Class 51 on sizes 12-inches and smaller, and Class 52 on sizes 14-inches and larger.

#### 501.9 STEEL PIPE AND FITTINGS

##### 501.9.3. PIPE AND FITTING REQUIREMENTS

##### *SUBSTITUTE THE SECOND TO LAST SENTENCE WITH THE FOLLOWING:*

All steel pipe to be furnished for this project shall be designed in accordance with AWWA M11 for the most critical application of internal pressures and external loads. The following design conditions shall apply:

Internal Pressure (Design to account for working and surge together)

- (1) Working Pressure of 200 PSI
- (2) Surge allowance of 250 PSI

External Loading for Buried Pipe





- (1) External loads shall be comprised of the weight of the backfill together with live and impact loads. Earth loads shall be calculated based on ditch and positive projecting conduit. The earth load for the pipe design shall be the greater of the above two conditions.
- (2) External live loads shall be at least equivalent to AASHTO HS-20 loading.
- (3) Modulus of soil reaction ( $E'$ ) < 1000 PSI
- (4) Unit weight of fill ( $w$ ) > 120 PCF
- (5) Deflection lag factor ( $D1$ ) (1.0)
- (6) Bedding constant ( $K$ ) = 0.100
- (7)  $hw = h$  = depth of cover above top of pipe
- (8) Maximum deflection in percent of pipe diameter shall be as determined by AWWA M11, latest edition, as calculated using moment of inertia of steel cross section of pipe wall. Moment of inertia of cement mortar shall not be included in calculation of maximum deflection.

#### Available Deflections

Mortar-lined and coated = two (2) percent of pipe diameter

#### Maximum Working Stress

The maximum combined stress based on working pressure shall be no greater than 50 percent of the minimum yield strength or 18,000 PSI, whichever is less.

The maximum combined stress based on test pressure shall be no greater than 75 percent of the minimum yield strength or 24,000 PSI, whichever is less.

### 501.9.4. JOINTS

#### *ADD THE FOLLOWING:*

In general, pipe joints shall be as follows, as indicated on the Drawings or as specified.

- (1) Flanged joints shall be provided as a minimum at all flanged valves, meters and other equipment.
  - (a) Flanges. Unless otherwise noted, flanges shall conform to the requirements of AWWA C207, Table D, E or F as required.
  - (b) Flange Bolts and Nuts. Shall be furnished in size and numbers stipulated in AWWA C207. Unless otherwise indicated, bolts shall be carbon steel to meet the requirements of ASTM Designation A307, Grade B for regular joints.
- (2) Restrained Lap-Welded slip joints (expanded bell) with a single fillet weld.
- (3) Carnegie-Shape Rubber Gasket Joint. Bell and spigot rubber gasket joint will be furnished with the bell end of the pipe mechanically expanded to the required internal diameter and the spigot end furnished as a sized Carnegie shape welded to the opposite end of the pipe. The expanded bell and Carnegie spigot shall be designed such that when the pipe is laid and jointed, it will be self-centered, and the O-ring rubber gasket will be enclosed tightly on all four sides and confined under compression adequate to ensure water tightness. Gaskets to be full-face for use with flat face flanges and ring type for use with raised face flanges. Gasket material for water service pipe shall be cloth inserted rubber sheet, 1/8-inch thick or red rubber, ASTM D1330, Grade 1. Gasket material for air piping shall be as above, but of EPDM.
- (4) Mechanical Couplings. Mechanical couplings designed to provide a stress relieving flexible joint shall consist of a cylindrical sleeve, two gaskets, two follower rings and a set of bolts and nuts.
  - (a) Sleeves. Manufactured of ASTM A53 steel for sizes ten (10) inches and smaller. ASTM A36 steel for sizes 12-inches and larger. Minimum sleeve length shall be five inches for pipe 12-inches and smaller, seven (7) inches for pipe 14-inches through 24-inches, and ten (10) inches for pipe larger than 24-inches.



- (b) Follower Rings. Ductile Iron ASTM A536 or AISI C1020 Steel.
- (c) Bolts and Nuts. High strength low alloy steel with heavy semi-finished hexagon nuts.
- (d) Gaskets. Shall be of synthetic rubber suitable for operating conditions.
- (e) Shop Finish. Manufacturer's standard unless otherwise noted.
- (f) Manufacturer. Baker 200, Dresser Style 39, Rockwell Series 411 or approved equal.

#### 501.14 POLYVINYL CHLORINE (PVC) WATER PIPE

##### *ADD THE FOLLOWING:*

All PVC water pipelines shall be AWWA C900-16 PVC Pipe (blue in color), DR 14 (PC 305) for pipeline sizes 12-inch and smaller, and DR 18 (PC 235) for 14-inch and larger water pipelines. All PVC water pipe shall be extruded PVC pipe of the rubber gasket type joint and shall be furnished in 20-foot nominal laying lengths.

All fittings shall be ductile-iron of bell and spigot or mechanical joint, Class 250, in accordance with AWWA Specification C 110, C 111 or C 153 (Compact), and shall be tar coated on the outside surface and shall have an interior cement lining with seal coat per AWWA Specification C104, unless otherwise shown in the plans.

#### ITEM 502. APPURTENANCES

#### 502.1 MANHOLES

##### 502.1.1. MANHOLE MATERIALS

##### 502.1.1.1. PRECAST REINFORCED MANHOLE SECTIONS

##### 502.1.1.1.1. JOINTS

##### *ADD THE FOLLOWING:*

All sanitary sewer manholes installed in the City of Rockwall, shall have "O" ring joints conforming with ASTM Designation C443

##### 502.1.4. MANHOLE CONSTRUCTION

##### 502.1.4.1. MANHOLE TYPES AND REQUIREMENTS

##### 502.1.4.1.1. CAST-IN-PLACE CONCRETE MANHOLES

##### *ADD THE FOLLOWING:*

##### 502.1.4.1.1.1. FORMS

Manholes shall be constructed in place in accordance with the details shown in the plans and using forms as market by Improved Construction Methods, Inc., Jacksonville, Arkansas or Symons Corp., DePlaines, Illinois, or an approved equal.

##### 502.1.4.1.1.2. BASE

The base shall be cast monolithically with the rest of the manhole. The invert and flow channel shall be formed during or immediately after the placing of the concrete and trowel-finished as soon as the



concrete has set sufficiently. The concrete must set for 24 hours before any pipe inside the manhole is trimmed. Concrete shall be minimum 4200 PSI.

The base concrete shall be 4200 PSI, maximum slump four (4) inches vibrated or tamped on undisturbed bearing. The base shall have a minimum diameter or width of at least one (1) foot greater than the outside diameter of the manhole, and a minimum thickness including the area under the pipe as follows:

0-FEET TO 12-FEET MANHOLE	12-INCH
12-FEET TO 20-FEET MANHOLE	15-INCH
20-FEET AND ABOVE	18-INCH

#### 502.1.4.1.1.3. INVERT

All invert channels shall be smooth and accurately shaped to a semi-circular bottom conforming to the inside of the adjacent sewer section. Inverts shall be formed directly in the concrete of the manhole base or may be constructed by laying full section sewer pipe through the manhole and breaking out the top half after the base is constructed. Inverts shall extend up at least half of the diameter of the pipe. Changes in the direction of the sewer and entering branches shall have a true curve of as large a radius as the size of the manhole will permit. Where the pipe is laid through the manhole, the invert shall be finished to  $\frac{1}{4}$ -inch below the center of the pipe. The pipe shall be trimmed down to  $\frac{1}{4}$ -inch below the surface of the invert, and the edges of the pipe along the invert and at the walls of the manhole shall be plastered and brush-finished. Plaster shall be two (2) parts of masonry sand to one (1) part of Portland cement, or an approved non-shrink grout.

#### 502.1.4.1.1.4. MANHOLE BARREL SECTION

The vertical forms, wall spaces, and placing cone must be carefully positioned and firmly clamped in place before any placement is made. The wall spacers must be located 90 degrees from each other. The manhole shall be cast of 4200 PSI concrete with a maximum slump of four (4) inches. The first placement shall consist of approximately  $\frac{1}{2}$  yard of concrete evenly around the walls and vibrated until there is a minimum slump of 60 degrees from the bottom of the forms to the bearing surface both inside and outside of the manhole. When this is complete and before additional concrete is added, the concrete must be carefully vibrated on each side of each pipe. Additional concrete must be deposited in evenly distributed layers of about 18-inches with each layer vibrated to bond it to the preceding layer. The wall spacers must be raised as the placements are made with the area from which the spacer is withdrawn being carefully vibrated. Excessive vibration is to be avoided. A maximum of two (2) percent calcium chloride may be added to the concrete, at the Contractor's option, to speed the set. The forms may be removed as soon as the concrete has sufficiently set (*approximately two [2] hours after placement depending on field conditions*).



Form marks and offsets up to one (1) inch will be permitted on the outside surface of the manhole. Form marks and offsets up to ½-inch will be permitted inside the manhole. All offsets on the inside surface of the manhole will be smoothed and plastered so there is no projection or irregularity capable of scratching a worker or catching and holding water or solid materials. Honeycomb will be plastered with a mortar consisting of three (3) parts of masonry sand and one (1) part Portland cement upon removal of the forms. Manholes deemed to be structurally unsound shall be replaced.

#### 502.1.4.1.1.5. BACKFILLING

Will be performed evenly and carefully around the manhole 24-hours or more after the placement of concrete is completed and shall conform to these specifications.

#### 502.1.4.1.1.6. COLD JOINTS

Should circumstances make a cold joint necessary, a formed groove or reinforcing dowels will be required in the top of the first placement for shear protection. Immediately before the second placement is made, the surface of the cold joint shall be thoroughly cleaned and wetted with a ½-inch layer of mortar (*two [2] parts sand and one [1] part cement*) being deposited on the surface. Cold joints below the natural water table or in the bottom four (4) feet of the manhole shall include an approved waterstop material. Waterstops shall be heavy duty polyvinyl conforming to Corps of Engineers Specification CRD-572, latest edition, as manufactured by Servicised Products Division of W.R. Grace and Co.; B.F. Goodrich Company; Electrovert, Inc.; W.R. Meadows, Inc.; or approved equal.

### 502.3 FIRE HYDRANTS

#### 502.3.1. MATERIALS

*DELETE ALL PARTS OF ITEM 502.3.1 IN ITS ENTIRETY EXCEPT SUB ITEMS 502.3.1.3, 502.3.1.4., 502.3.1.10, AND 502.3.1.14.*

*ADD THE FOLLOWING:*

All fire hydrants furnished shall conform strictly with the latest specification C-502 of the American Water Works Association Standards for dry barrel fire hydrants and must comply with the following supplementary details and changes or addition.

- (a) Inlet Connection. Unless otherwise specified, the inlet connection shall be a six (6) inch standard mechanical joint complete with all joint accessories. The inlet shoe shall be cast of the same or stronger metal than the lower barrel to prevent impact damage of the shoe. The interior of the shoe, including the lower valve plate and/or cap nut shall have a protective epoxy coating of at least four (4) mils applied in the shop. If a cap nut is utilized it must be locked in place with a stainless-steel lock washer or similar non-corrosive device and all machined surfaces must be protected from water intrusion to prevent corrosion and assure ease of field teardown or maintenance.
- (b) Main Valve. The main valve shall be reversible compression type, closing with the pressure and shall be not less than 5¼-inch in diameter. Composition of the main valve shall be molded rubber or neoprene having a



durometer hardness of 90 + 5 and shall be not less than one (1) inch thick to protect against hydrant chatter and give long term durability.

- (c) Outlet Nozzles. All hydrants shall be “three way”, equipped with two hose nozzles and one pumper nozzle.
- (d) Diameter Outlet Nozzles. The hydrant shall have two hose nozzles, 2½-inches nominal I.D., and one pumper nozzle 4½-inches nominal I.D. with Natural Standard Hose Threads.
- (e) Nozzle Attachment. All nozzles shall be mechanically connected into the barrel and have “O” Ring pressure seals to provide a positive seal between nozzles and hydrant barrel. A suitable nozzle lock shall be provided and shall be stainless-steel or bronze. Nozzles shall not be caulked in. Nozzle caps shall be furnished with pentagon nut the same size as the operating nut. They shall be furnished with interior rubber gaskets that will seat against bronze nozzles. All caps shall be secured to hydrant barrel by heavy duty non-kinking chains with a chain loop on each cap that permits free turning of the cap, for speed and ease of removal by fire fighters.
- (f) Operating Nut. The operating nut shall be non-rising, pentagonal shape, measuring 1¼-inch at the top and 1½-inch at the base from point to flat. Pentagon shall have a depth of at least 1¼-inch. The hydrant shall be constructed in such a manner that the operating nut, “O” Rings and washers can be removed and replaced without removing the bonnet. All bearing surfaces of the operating nut shall be bronze.
- (g) Holddown Nut. Holddown nut must have integral weather seal. Resilient seal between holddown nut and operating nut shall prevent debris entry to protect operating nut from damage.
- (h) Lubrication Reservoir. The hydrant shall have a completely “O” Ring sealed oil reservoir with a minimum of two (2) “O” Ring pressure seals to prevent contamination of the oil around the operating parts of the hydrant. The oil reservoir shall be cast in such a manner that all operating parts shall be repairable without removal of the bonnet to facilitate repairs and shall be of a design that all bearing surfaces and threaded parts will be automatically lubricated upon each operation of the hydrant. If bearing surfaces are not lubricated, the design shall keep operating friction to a minimum. A high wear resistant thermoset plastic anti-friction washer shall be in place above the thrust collar to minimize operation torque and facilitate long term ease of operation. The operating threads must be sealed against contact with water to all times regardless of open or closed position of main valve. The hydrant shall have the capability of field personnel to visually check oil level and add additional oil if needed. Filler and inspection plug shall be recessed or flush type.
- (i) Traffic Feature. Hydrants shall be “traffic model” having upper and lower barrel joined approximately two (2) inches above the ground line by a breakable “swivel” flange providing 360-degree rotation of the upper barrel for nozzle positioning and must be capable of rotating barrel with line pressure on. The ground line shall not be less than 18-inches below the centerline of the lowest nozzle and shall be clearly marked in a permanent manner on the lower barrel. A breakable stainless-steel stem coupling shall join the two-piece stem adjacent to the ground line flange. Screws, clevis pins, fasteners or bolts used in the coupling shall be Series 300 stainless-steel. The weakened portion of the stem coupling shall be located to divert pressure from the stem coupling directly to the upper and lower stems when torque is applied in seat ring removal. Design of the coupling shall be such that when the coupling is broken, no part of the coupling will shatter or come loose and fall into hydrant and the break will not occur through the pins or bolts holding the coupling to the stem.
- (j) Drain Valve Assembly. Hydrants shall be equipped with two drain valves which drain the barrel when the hydrant is closed and seal shut when the hydrant is in the open position. The upper valve plate, seat ring and drain ring (*shoe bushing*) must be bronze and work in conjunction to form an all bronze drain way. Upper valve plate if not bronze, must be epoxy coated. The bronze seat ring shall be a minimum 5¼-inch inside diameter and shall thread into a bronze drain ring forming an all bronze drain way with two (2) drain outlets for double protection against drain clogging and corrosive damage. All bronze components shall have less than 16 percent zinc alloy, Grade A to give high corrosion resistance as recommended in *Section 2.1, Table I of American Water Works Association Standard C-502*. Seat ring seals shall be “O” Rings. Hydrant shall be designed so that during opening and closing operation(s), water pressure force flushes the drain valve and drain openings to prevent clogging, thus allowing barrel drainage.
- (k) Repair. All internal operating parts shall be removable from above ground level with a lightweight stem wrench.
- (l) Provisions for Extension. All hydrants shall be capable of being extended to accommodate future grade changes without excavation. Extension of the hydrant shall be made by adding at the groundline flange a new coupling and stem section equal to the length of the extension. This must facilitate easy field grade adjustment.

Stem extensions made by adding new section of stem to the threaded section of the stem at the top of the hydrant will not be accepted. Extension kits must be available from manufacturer in six (6) inch increments.

- (m) Pressure Loss and Working Pressure. Pressure loss through one (1), 4½-inch nozzle at 1,000 GPM shall not be more than five (5) PSI.
- (n) Nuts and Bolts. Body Bolts, studs and nuts shall be 316 stainless-steel.

**ADD THE FOLLOWING:**

502.3.4. PAINT AND PROTECTIVE COATINGS

All fire hydrants furnished under these specifications shall have paint and protective coatings applied at the factory or in the field as specified herein.

(a) Factory Coating.

All hydrants shall be cleaned at the factory by shot blasting and shall be painted above the groundline (*at the factory*) with two (2) coats of neutral orange rust-prohibitive primer which shall be compatible with the finished coating.

All continuously wetted ferrous metal surfaces in the hydrant shoe shall be protected with a two-part thermoset epoxy coating to a nominal thickness of four (4) mils of corrosion protection and shall be of a color that is easily identified as an epoxy coating. All other exposed exterior surfaces below ground level shall be coated with asphalt varnish as specified in *American Water Works Association Standard C-502, Section 4.2* or as otherwise outlined in these specifications. All remaining interior surfaces above the main valve, except machined surfaces such as the threaded portion of the operating stem or nut, shall be coated with asphalt varnish.

The thermoset epoxy coating shall be a two (2) part epoxy and shall function as a physical, chemical and electrical barrier between the base metal to which it is applied and the surroundings. The coating shall be non-toxic and shall not impart taste to water. The coating must be formulated from materials deemed acceptable per the *Food & Drug Administration Document Title 21 of the Federal Regulations of Food Additives, Section 121.2514 entitled Resins & Polymeric Coatings*. The coating shall have a satin finish and shall be suitable for field overcoating and touch-up with the same coating material without sanding or special surface preparation, or application of heat in excess of room temperatures.

(b) Field Coatings.

All hydrants shall be field painted at the time the Contractor is instructed by the Public Works Inspector and shall be painted above ground with two (2) coats of aluminum paint, Mobil 11-A-19 or Tnemec 2-color, Tnemec-Gloss or approved equal according to the following color schedule:

WATER MAIN SIZE	BONNET AND CAPS COLOR
6"	SILVER
8"	BLUE
10" & LARGER	YELLOW

**ADD THE FOLLOWING:**

502.3.5. EXPERIENCE AND CERTIFICATION

Fire hydrants, furnished under these specifications, shall be manufactured by a firm that has been producing hydrants of this general type continuously for the past five (5) years. Each company or manufacturer supplying hydrants under these specifications shall have on file, at the City of Rockwall, approved records of experience and detailed drawings of the proposed hydrants. Drawings shall cover the specific hydrant to be furnished for installation in the City and shall show all dimensions including metal thickness, construction details and materials used in all parts of the hydrant together with ASTM Designation and structural properties of these materials.

For ease of identification, all hydrants shall have “City of Rockwall, Texas” stenciled on the lower barrel. This stencil shall be applied at the factory. The manufacturer shall furnish to the City of Rockwall, a Certification that the fire hydrant complies with the specifications without any exceptions. This certification shall apply to specific hydrants being installed within the City water distribution system. The certification shall state [1] the number of hydrants covered by the certification, [2] the Addition where hydrants are being installed or the Project Name and [3] name of Contractor installing hydrants.

The City may require the Manufacturer, Supplier or Contractor to dismantle hydrants at any time to determine compliance with these specifications. Location of any hydrant within the City system, installed after adoption of these specifications, that does not meet the specifications completely shall be cause for prohibiting the future use of any hydrants from the same manufacturer.

502.5 FITTINGS

502.5.1. BRASS STOPS, COCKS AND FITTINGS FOR WATER WORKS SERVICE

*ADD THE FOLLOWING:*

502.5.1.2. PHYSICALS

All pressure holding components of brass stops or fittings shall be certifiably pressure tested before assembly as specified herein, including meter coupling tailpieces, flared nuts, compression nuts, etc.

502.5.1.3. DESIGN FEATURES OF STOP AND COCKS

The stem end of the key, prestaked key nut and the “D” washer shall be so designed that they turn in unison and if tightened to the failure point, the stem will not break causing the key to blow out.

Corporation, curb and angle stop bodies shall be of one (1) piece construction to provide optimum resistance to installation, operating and earth-load stresses. The operating head and checks of these stops shall be integrally cast with the plug or cap of the stop for maximum resistance to torque feature.

Angle valves shall have a lockwing and shall be “O” ring sealed at the top of the key to prevent leakage during operation and to act as a secondary protection against external top leakage. Meter swivel nuts shall be of the saddle nut construction to support the meter during installation. Inlet flare and compression parts for angle valves shall be field interchangeable on ¾-inch and one (1) inch sizes to make repairs easier and more economical.

502.5.1.4. DESIGN FEATURES OF FITTINGS

*ADD THE FOLLOWING TO THE THIRD PARAGRAPH OF THIS ITEM:*

Flare joints shall have curved metal to metal seating surfaces and flare nuts shall meet the following overall minimum length to insure that the flare nut will give adequate pipe support to this type of joint.

MINIMUM FLARE NUT	OVERALL LENGTH
¾-INCH	1½-INCH
1-INCH	2-INCH
1½-INCH	3-INCH
2-INCH	3½-INCH

Add the following to the sixth paragraph of this item:



All stops and fitting joints shall be of the compression type for copper pipe unless otherwise noted. Compression coupling nuts shall be designed to “bottom out” on a machined shoulder on the fitting to provide a visual check for proper assembly and eliminate field judgment errors of the installation. The coupling nut shall house the compression gasket in a smooth machined area and shall be internally coated with a fluorocarbon (Teflon) lubricant to prevent gasket damage and reduce installation torques. The compression gasket shall be a heavy armored gasket to provide electrical continuity through the fitting and prevent gasket cold flow and shall house a concave hardened stainless-steel overlapping gripper band that is automatically activated and set by shouldering out the fitting properly.

Minimum pullout (*or tensile strength*) required of these fittings after installation to protect against earthloads are as follows:

¾-INCH	2,000 LBS
1-INCH	3,000 LBS
1½-INCH	3,500 LBS
2-INCH	4,000 LBS

All outlet threads on compression connections shall be compatible with the City’s present drilling and tapping machine equipment.

## 502.6 VALVES

### 502.6.1. METAL-SEATED GATE VALVES FOR ORDINARY WATER WORKS SERVICE

#### 502.6.1.2. BONNET BOLTING

*DELETE IN ITS ENTIRETY AND REPLACE WITH THE FOLLOWING:*

Body Bolts, studs and nuts shall be 316 stainless-steel.

### 502.6.2. RESILIENT-SEATED GATE VALVES FOR ORDINARY WATER WORKS SERVICE

#### 502.6.2.1. GENERAL DESCRIPTION

*ADD THE FOLLOWING:*

Unless otherwise approved in writing, all Gate Valves for direct buried service in the City’s distribution system, six (6) inches through 12-inches in diameter, shall be Resilient Seated Gate Valves that conform strictly with the latest specification C-509 of the American Water Works Association Standards and must comply with the following supplementary details, changes or additions. Gate valves shall be iron body designed for a working pressure of 250 PSI. All valves shall be hydrostatically tested at 200 PSI and shell tested at 500 PSI. Any leakage during testing shall be cause for rejection. For ease of repair the body, bonnet and stuffing box shall be flanged together with ASTM Grade B bolts and nuts. Each valve shall have the maker’s initials, pressure rating, and year in which manufactured cast in the body.

#### 502.6.2.2. BONNET BOLTING

*DELETE IN ITS ENTIRETY AND REPLACE WITH THE FOLLOWING:*

Body Bolts, studs and nuts shall be 316 stainless-steel.

#### 502.6.2.5. VALVE STEM AND NUTS

*ADD THE FOLLOWING:*





Stems shall be machined from manganese bronze rod with an integral forged thrust collar machined to size. The stems shall be non-rising and equipped for nut operation, which shall be opened by turning to the left. The seals shall consist of two "O" rings above and one "O" ring below the thrust collar. An anti-friction washer shall be located above and below the thrust collar for operating torque. The stem nut shall be ASTM B-62 bronze.

#### 502.6.2.17. RESILIENT WEDGE

##### *ADD THE FOLLOWING:*

The wedge shall be cast iron, fully encapsulated in molded rubber complying with ASTM D2000. Wedge must have molded wedge guides preventing the disc from tilting downstream during operation. Protective guide cap bearings made of polymer bearing material to provide a bearing interface between the wedge guide and valve interior.

#### 502.6.2.18. PAINT AND PROTECTIVE COATINGS:

##### *ADD THE FOLLOWING:*

All valves furnished under these specifications shall be painted on the exterior as specified in AWWA C-509 with asphalt varnish.

All ferrous metal surfaces in the internal part of the valve shall be protected with a fusion epoxy coating to a nominal thickness of ten (10) mils for corrosion protection and shall be of a color that is easily identified as an epoxy coating.

The proguard fusion epoxy coating shall fully comply with AWWA C550 and certified NSF 61. The coating shall be non-toxic and shall not impart taste to water. The coating must be formulated from materials deemed acceptable per the *Food & Drug Administration Document Title 21 of the Federal Regulations of Food Additives, Section 121.2514* entitled *Resins and Polymeric Coatings*. The coating shall have a satin finish and shall be suitable for field overcoating and touchup with the same coating material without sanding or special surface preparation, or application of heat in excess of room temperature.

#### 502.6.2.19. EXPERIENCE AND CERTIFICATION

##### *ADD THE FOLLOWING:*

Valves, furnished under these specifications, shall be manufactured by a firm that has been producing valves of this general type continuously for the past five (5) years. Each company or manufacturer supplying valves under these specifications shall have on file, with the City of Rockwall, approved records of experience and detailed drawings of the proposed valves. Drawings shall cover the specific valve to be furnished for installation and shall show all dimensions including metal thickness, construction details and materials used in all parts of the valve together with ASTM Designation and Structural properties of these materials.

The manufacturer shall furnish to the City of Rockwall, a Certification that the valve complies with the specifications without any exceptions. This certification shall apply to specific valves being installed within the City water distribution system. The certification shall state [1] the number of valves covered by the certifications, [2] the Addition where valves are being installed or the Project Name, and [3] name of Contractor installing valves.

The City may require the Manufacturer, Supplier or Contractor to dismantle valves at any time to determine compliance with these specifications. Location of any valve within the City system, installed



after adoption of these specifications, that does not meet the specifications completely shall be cause for prohibiting the future use of any valves from the same manufacturer.

#### 502.6.2.20. TAPPING SLEEVES

##### *ADD THE FOLLOWING:*

The materials for tapping sleeve bodies shall be, by City approval only, cast-iron or ductile-iron in accordance with AWWA Standard C110 (ANSI 21.10), in two sections, or halves to be bolted together with high-strength, corrosion resistant, low alloy steel bolts conforming to AWWA Standard C111 (ANSI 21.11).

Cast iron and ductile-iron sleeve shall be mechanical joint, or as specified, or dimensions to secure proper fit on the type and class of pipe on which they are to be used. Each sleeve shall be furnished with a  $\frac{3}{8}$ -inch test opening so that tests can be made prior to tapping. Opening shall be provided with a  $\frac{3}{8}$ -inch bronze plug.

#### 502.6.5. BUTTERFLY VALVES

##### *ADD THE FOLLOWING:*

All Butterfly Valves for installation underground in the City's distribution system 16 inches through 48 inches shall be in accordance with this specification.

All butterfly valves furnished shall conform strictly with the latest specification C-504 of the American Water Works Association Standard for rubber-seated butterfly valves and must comply with the following supplementary details and changes or addition.

- (a) Body. The body shall be cast-iron ASTM A126, Class B and shall have face to face dimensions in accordance with AWWA Standards for short body, Class 150-B. All butterfly valves shall have a floating body seat ring to compensate for change in direction of flow to assure bottle-tight seal in either direction.
- (b) Shaft. Valve shafts shall be an 18-8, Type 316 stainless-steel. Valve disc and shaft shall be standard self-adjusting Chevron "V" type packing. Shaft seals shall be of a design allowing replacement without removing the valve shaft.
- (c) Disc and Seat. The valve disc shall be cast iron ASTM A126, Class B. The valve seat shall be Buna-N located on the valve body. Valves 20-inch and smaller shall have a bonded seat that meets test procedures in ASTM D429, Method B. Valves 24-inch and larger shall be retained in the valve body by mechanical means without the use of metal retainers or other devices located in the flow stream.
- (d) Operator. Butterfly valve operators shall be of the traveling nut design. All operators shall have adjustable mechanical stop limiting devices to prevent over travel of the disc. The operator shall have a mechanical stop which will withstand an input torque of 450-foot/LBS. against the stop. The traveling nut shall engage alignment grooves in the housing.
- (e) Operation. Unless otherwise shown in the plans, all valves shall open counter clockwise.
- (f) Valve Ends. Valve ends shall be Mechanical Joint End, or Flanged Ends. Mechanical joint valves shall come complete with bolts, nuts, gaskets and glands. It shall be the responsibility of the Contractor to coordinate the ends of the adjoining pipe with the type valve end he/she proposes to use.
- (g) Testing. All valves seats shall be tested at 150 PSI as described in AWWA C-504 and in addition shall have a shell test of 300 PSI. Any leakage shall be cause for rejection.
- (h) Paint and Protective Coatings. All butterfly valves furnished under these specifications shall be painted on exterior as specified in AWWA C-504, with asphalt varnish.

All ferrous metal surfaces in the internal part of the valve shall be protected with a two-part thermoset epoxy coating to a nominal thickness of 4 mils for corrosion protection and shall be of a color that is easily identified as an epoxy coating. This shall be applied in shop.



The thermoset epoxy coating shall be a two-part epoxy and shall function as a physical, chemical and electrical barrier between the base metal to which it is applied and the surroundings. The coating shall be non-toxic and shall not impart taste to water. The coating must be formulated from materials deemed acceptable per the *Food & Drug Administration Document Title 21 of the Federal Regulations of Food Additives, Section 121.2514* entitled *Resins & Polymeric Coatings*. The coating shall have a satin finish and shall be suitable for field overcoating and touchup with the same coating material without sanding or special surface preparation, or application of heat in excess of room temperatures.

- (i) *Experience and Certification*. Butterfly valves, furnished under these specifications, shall be manufactured by a firm that has been producing valves of this general type continuously for the past five (5) years. Each company or manufacturer supplying valves under these specifications shall have on file, at the City of Rockwall, approved records of experience and detailed drawings of the proposed valves. Drawings shall cover the specific valve to be furnished for installation in the City of Rockwall and shall show all dimensions including metal thickness, construction details and materials used in all parts of the valve together with ASTM Designation and structural properties of these materials.

The manufacturer shall furnish to the City, a Certification that the valve complies with the specifications without any exceptions. This certification shall apply to specific valve being installed with the City water distribution system. The certification shall state [1] the number of valves covered by the certification, [2] the Addition where valves are being installed or the Project Name and [3] name of Contractor installing valves.

The City may require the Manufacturer, Supplier or Contractor to dismantle valves at any time to determine compliance with these specifications. Location of any valve with the City system, installed after adoption of these specifications, that does not meet the specifications completely shall be cause for prohibiting the future use of any valves from the same manufacturer.

## ITEM 504. OPEN CUT – BACKFILL

### 504.2 MATERIALS

#### 504.2.2. PIPE BEDDING MATERIAL FOR STORM, WATER AND SANITARY SEWER MAINS

##### *ADD THE FOLLOWING:*

Unless otherwise indicated, storm sewer pipe shall be bedded with Class “C” bedding in accordance with the details shown on the plans.

#### 504.2.2.1. CRUSHED STONE EMBEDMENT

##### *ADD THE FOLLOWING:*

Where stone is called out for pipe embedment, Standard Crushed Rock-Aggregate, Grade 4, shall be used unless otherwise approved in writing.

### 504.3. EXCAVATION AND FOUNDATION

##### *ADD THE FOLLOWING:*

#### 504.3.1 EXCAVATION

##### *ADD THE FOLLOWING:*

Prior to start of excavation the Contractor shall remove and stockpile the Topsoil and protect the Topsoil from contamination during construction.

### 504.5 EMBEDMENT



*ADD THE FOLLOWING:*

Rock Cuttings will not be permitted in the pipe bedding for sanitary sewer or water lines in the City of Rockwall.

504.5.2. EMBEDMENT CLASSES

504.5.2.9. CLASS "C" EMBEDMENT

*REPLACE THE LAST SENTENCE IN ITS ENTIRETY WITH THE FOLLOWING SENTENCE:*

Density shall be at least 95 percent of maximum density, as determined by ASTM D698.

504.5.2.15. CLASS "H" EMBEDMENT

Class "H" Embedment shall be used on the PVC Sanitary Sewer Pipe installed within the City of Rockwall.

On PVC Pipe 18-inches through 27-inches in diameter the crushed stone shall be brought up in uniform layers to a point nine inches over the top of the pipe when compacted.

504.6. FINAL BACKFILL

*ADD THE FOLLOWING:*

After the trench has been refilled, topsoil shall be replaced to the extent that rock, excavated from the trench, will be completely covered and the area is returned to its original condition, except that in cultivated areas a minimum of 12-inches of top soil shall be replaced.

504.6.1. EXCAVATED MATERIAL

*ADD THE FOLLOWING:*

The material used in the backfill shall be pulverized to the extent necessary to produce a free-flowing material free of clay balls larger than 6-inch diameter.

ITEM 506. OPEN CUT - WATER CONDUIT INSTALLATION

506.3. LAYING WATER CONDUIT

*ADD THE FOLLOWING:*

Valves for installation in the City's distribution system shall be installed by direct burial as shown on the standard detail sheets and shall be provided with valve boxes for operation of the valve.

506.5 HYDROSTATIC TEST

*DELETE FIRST PARAGRAPH AND TABLE AND REPLACE WITH:*

All hydrostatic tests shall be maintained over a period of not less than four hours.

"Before being accepted, all ductile iron, C-900 PVC or concrete cylinder water mains shall be tested with a hydraulic test pressure of not less than four hours. Concrete pressure pipe shall be tested with a hydraulic test pressure of 120 percent of the design pressure. Steel pressure pipe shall be tested with a hydraulic test pressure not to exceed 150 percent and not less than 120 percent of the designed working pressure. The rate of leakage of all pipe tested shall not exceed the amounts shown in the

tables titled “Hydrostatic Test-C-900 PVC, Steel or Ductile Iron Water Mains” or “Hydrostatic Test-Concrete Cylinder Water Mains”. Water lines of material in combination shall be tested for the type of pipe (material) with the least stringent hydraulic test pressure and maintained over a period of not less than four hours.”

**TABLE:** HYDROSTATIC TEST (C900-16 PVC, STEEL OR DUCTILE-IRON WATER MAINS)

LF PIPE	GALLONS ALLOWED								
	PIPE DIAMETER								
	4"	6"	8"	10"	12"	14"	16"	18"	20"
5	0.016	0.024	0.032	0.039	0.047	0.055	0.063	0.071	0.079
10	0.032	0.047	0.063	0.079	0.095	0.110	0.126	0.142	0.158
20	0.063	0.095	0.126	0.158	0.189	0.221	0.253	0.284	0.316
30	0.095	0.142	0.189	0.237	0.284	0.331	0.379	0.426	0.473
40	0.126	0.189	0.253	0.316	0.379	0.442	0.505	0.568	0.631
50	0.158	0.239	0.316	0.395	0.473	0.552	0.631	0.710	0.789
60	0.189	0.284	0.379	0.473	0.568	0.663	0.758	0.852	0.947
70	0.221	0.331	0.442	0.552	0.663	0.773	0.884	0.994	1.105
80	0.253	0.379	0.505	0.631	0.756	0.884	1.010	1.136	1.263
90	0.284	0.426	0.568	0.710	0.852	0.994	1.136	1.278	1.420
100	0.316	0.473	0.631	0.789	0.947	1.105	1.263	1.420	1.578
200	0.631	0.947	1.263	1.578	1.894	2.210	2.525	2.841	3.157
300	0.947	1.420	1.894	2.367	2.841	3.314	3.788	4.261	4.735
400	1.263	1.894	2.525	3.157	3.788	4.419	5.051	5.682	6.313
500	1.578	2.367	3.157	3.946	4.735	5.524	6.313	7.102	7.891
600	1.894	2.841	3.788	4.735	5.682	6.629	7.576	8.523	9.470
700	2.210	3.314	4.419	5.524	6.629	7.734	8.838	9.943	11.048
800	2.525	3.788	5.051	6.313	7.576	8.838	10.101	11.364	12.626
900	2.841	4.261	5.682	7.102	8.523	9.943	11.364	12.784	14.205
1000	3.157	4.735	6.313	7.891	9.470	11.048	12.626	14.205	15.783

Maximum allowable water loss in 4 hours at 180 pounds per square inch of pressure for a rate of 25 gallons per inch diameter of pipe per mile over a 24-hour period

EQUATION THE ABOVE CHART IS BASED ON:

$$\text{Maximum Loss (Gal.)} = 25 \times \text{Diameter of Pipe (inches)} \times \frac{\text{L.F. of Pipe}}{5280 \text{ Pipe}} \times \frac{4}{24}$$

**TABLE:** HYDROSTATIC TEST (CONCRETE CYLINDER WATER MAINS)

LF PIPE	GALLONS ALLOWED								
	PIPE DIAMETER								
	4"	6"	8"	10"	12"	14"	16"	18"	20"
5	0.031	0.047	0.063	0.078	0.095	0.110	0.126	0.142	0.158
10	0.063	0.095	0.126	0.158	0.189	0.221	0.253	0.284	0.315
20	0.126	0.189	0.253	0.316	0.379	0.442	0.505	0.568	0.631
30	0.188	0.284	0.379	0.473	0.568	0.663	0.758	0.852	0.947
40	0.253	0.379	0.505	0.631	0.758	0.884	1.010	1.136	1.263
50	0.316	0.473	0.631	0.789	0.947	1.105	1.263	1.420	1.578
60	0.379	0.568	0.758	0.947	1.136	1.326	1.515	1.704	1.894
70	0.442	0.663	0.884	1.105	1.326	1.547	1.768	1.989	2.210



80	0.505	0.758	1.010	1.263	1.515	1.768	2.020	2.273	2.525
90	0.568	0.852	1.136	1.420	1.704	1.989	2.273	2.557	2.841
100	0.631	0.947	1.263	1.578	1.894	2.209	2.525	2.841	3.156
200	1.263	1.894	2.525	3.156	3.788	4.419	5.050	5.682	6.313
300	1.894	2.841	3.788	4.735	5.682	6.628	7.575	8.522	9.470
400	2.525	3.788	5.050	6.313	7.575	8.838	10.100	11.363	12.626
500	3.158	4.735	6.313	7.891	9.470	11.047	12.626	14.204	15.782
600	3.788	5.682	7.575	9.469	11.363	13.257	15.151	17.045	18.938
700	4.419	6.628	8.838	11.047	13.257	15.468	17.676	19.885	22.095
800	5.050	7.575	10.100	12.626	15.152	17.676	20.201	22.726	25.251
900	5.682	8.522	11.363	14.204	17.044	19.886	22.726	25.567	28.405
1000	6.313	9.469	12.626	15.782	18.939	22.096	25.253	28.408	31.564

Maximum allowable water loss in 4 hours at 180 pounds per square inch of pressure for a rate of 50 gallons per inch diameter of pipe per mile over a 24-hour period

EQUATION THE ABOVE CHART IS BASED ON:

$$\text{Maximum Loss (Gal.)} = 50 \times \text{Diameter of Pipe (inches)} \times \frac{\text{L.F. of Pipe}}{5280 \text{ Pipe}} \times \frac{4}{24}$$

**ITEM 507. OPEN CUT – WASTEWATER CONDUIT INSTALLATION**

507.5. TESTS AND INSPECTIONS

507.5.2. TELEVISION INSPECTION

*ADD THE FOLLOWING TO THIS SECTION:*

All sanitary sewer pipe construction in this contract shall be visually inspected by photographic means (television and video taped) prior to final acceptance by the Owner. No separate measurement or payment shall be provided for the video inspection. All labor, materials and equipment required are subsidiary to the appropriate bid items as established in the *Proposal and Bid Schedule*.

**ITEM 508. OPEN CUT – STORM WATER CONDUIT INSTALLATION**

*ADD THE FOLLOWING:*

508.8 INSPECTION

All storm sewers shall be visually inspected by photographic means (television and video taped), at Contractor’s expense, prior to final acceptance by the City. Any sags, open joints, cracked pipes, etc. shall be repaired or removed by the Contractor at Contractor’s expense. Pipes will be cleaned prior to televising the pipe. The contractor shall furnish a DVD formatted video to the City.

**ITEM 509. CROSSINGS**

509.5. CREEK AND RIVER CROSSINGS

*ADD THE FOLLOWING:*

509.5.1. AERIAL CROSSINGS



#### 509.5.1.1. GENERAL

Piers for aerial crossings will be drilled piers and columns of the diameter shown on the plans. Piers shall be founded at least six (6) feet into firm gray limestone and eight (8) feet into undisturbed material, unless otherwise directed by the Owner.

Materials and workmanship required to construct piers and cap shall conform to Reinforced Concrete Structures, of the specifications. Concrete of piers shall be 4,200 PSI.

Anchor straps and bolts shall be installed as shown on the plans, and shall be hot dipped galvanized after fabrication.

After installing the aerial crossing, including the junction collars with the main sewer pipe, an approved coal tar mastic jointing compound shall be installed the full inside circumference of the pipe at each joint to produce a smooth surface with no sharp flow transitions.

#### 509.5.1.2. STEEL PIPE

Steel pipe used of Aerial Crossings shall be of the diameter and wall thickness shown on the plans and shall be line pipe manufactured in accordance with the following specifications:

- (1) AWWA C200-75 Mill Type Steel Water Pipe, Grade B
- (2) ASTM A139, Grade B

Pipe shall be designed for a clear span as shown on the plans. Couplings shall be Dresser Type 38, or approved equal and shall be located as shown on the plans. Bolts shall be stainless-steel or galvanized.

The steel pipe sizes shown on the plans are the nominal diameters of the minimum size steel pipe which may be furnished and installed. Pipe of a larger size may be furnished at the Contractor's option, but no extra payment will be allowed. If larger pipe is utilized, it shall be set so as to retain the flow lines designated on the plans.

All steel pipe shall receive an interior shop-applied Liquid Epoxy Coating System in conformance with AWWA C-210, latest revision.

#### 509.5.1.3. EXTERIOR PAINTING

Exterior painting for aerial crossings shall conform to Item 804.2.

All surface prepared in the field shall be inspected by the City of Rockwall for adequate surface preparation as defined above prior to application of paint coating. All surfaces to be painted in the field shall have their readiness for painting approved by the City of Rockwall before work is started.

Paint shall be applied to all ferrous material part of the aerial crossing including but not limited to pipe, couplings, straps, nuts, bolts, etc.

##### 509.5.1.3.1. PAINTS

Paints for aerial crossings shall be:

- (1) TNEMEC Series 66, or Mobile 78 Series, or Koppers 200 HB, 5.0 mil dry film thickness each coat.
- (2) TNEMEC Series 66, or Mobile 78 Series, or Koppers 200 HB, 6.0 mil dry film thickness each coat.



Approved material of other manufacturers which are equivalent in all respects to the brands named above, may be substituted upon approval. All paint applied must be by the same manufacturer. The color on the final coat shall be selected by the City of Rockwall.

#### 509.5.1.4. MEASUREMENT OF PAYMENT

Aerial crossings will be measured for payment per each between the limits shown on the plans and will be paid for at the lump sum bid price for each crossing in the Bid Schedule.

Concrete piers and collars to the elevations shown in the plans will be measured and paid for in the lump sum price for aerial crossings. Payment in vertical feet for additional depth of reinforced concrete piers as approved by the City of Rockwall, shall be as provided in the Proposal and Bid Schedule.

Payment of the unit or lump sum prices shall be full compensation for furnishing all labor, supervisions, materials, tools, equipment, and incidentals, and for performing all work necessary in construction the aerial crossings and piers, including excavation, dewatering, backfilling, disposal of surplus material, painting, testing, concrete encasement, hauling, transportation costs, disposal costs, salvaging, and any other work required in accordance with the Plans and Specifications.

### SECTION 7.06 | DIVISION 600. CONDUIT AND APPURTENANCE REHABILITATION

*NOTE:* THE (1) SYMBOL SPECIFIES THAT THIS ITEM IS ALSO COVERED IN THE CITY OF ROCKWALL'S "SPECIAL PROVISIONS" TO THE "STANDARD SPECIFICATIONS FOR PUBLIC WORKS CONSTRUCTION, NORTH CENTRAL TEXAS". THESE SPECIAL PROVISIONS ARE ADDITIONAL AND MODIFY THE "STANDARD SPECIFICATION"

#### TABLE 7.6: REVISIONS TO NCTCOG'S DIVISION 600 CONDUIT AND APPURTENANCE REHABILITATION

REVISED	STANDARD SPECIFICATION ITEM NO.	DESCRIPTION
	<b>601</b>	<b>PIPELINE REHABILITATION</b>
	601.1	DESCRIPTION
	601.2	GENERAL
	601.3	GENERAL MATERIALS
	601.4	GENERAL METHODS
	601.5	SECTION HELD FOR FUTURE USE
	601.6	SECTION HELD FOR FUTURE USE
	601.7	CURED-IN-PLACE PIPE LINER (CIPP LINER)
	601.8	PIPE BURSTING WITH POLYETHYLENE
	601.9	PIPE BURSTING WITH RIGID PLACE
	601.10	POLYVINYL CHLORIDE (PVC) PROFILE GRAVITY LINER PIPE (SEGMENTAL SLIPLINING)
	601.11	MEASUREMENT AND PAYMENT
	<b>602</b>	<b>REHABILITATION OF MANHOLES OR UNDERGROUND VAULTS</b>
	602.1	GENERAL
	602.2	SUBMITTALS
	602.3	QUALITY ASSURANCE
	602.4	DELIVERY, STORAGE AND HANDLING
	602.5	REHABILITATION
	602.7	INSPECTION AND TESTING
	602.8	MEASUREMENT AND PAYMENT
	<b>603</b>	<b>ABATEMENT OF COATINGS CONTAINING HEAVY METALS</b>
	603.1	GENERAL
	603.2	JOB PLAN





603.3	TESTING
603.4	MONITORING
603.5	PROTECTION
603.6	LEAD-BASED COATING REMOVAL
603.7	LEAD-BASED COATING ENCAPSULATION
603.8	CLEAN-UP AND DISPOSAL
603.9	PAYMENT
<b>604</b>	<b>REMOVAL OF ASBESTOS-CEMENT PIPE (ACP)</b>
604.1	GENERAL
604.2	JOB PLAN
604.3	PROCEDURES
604.4	DISPOSAL
604.5	PAYMENT

**SECTION 7.07 | DIVISION 700. STRUCTURES**

*NOTE:* THE (1) SYMBOL SPECIFIES THAT THIS ITEM IS ALSO COVERED IN THE CITY OF ROCKWALL'S "SPECIAL PROVISIONS" TO THE "STANDARD SPECIFICATIONS FOR PUBLIC WORKS CONSTRUCTION, NORTH CENTRAL TEXAS". THESE SPECIAL PROVISIONS ARE ADDITIONAL AND MODIFY THE "STANDARD SPECIFICATION"

**TABLE 7.7: REVISIONS TO NCTCOG'S DIVISION 700 STRUCTURES**

REVISED	STANDARD SPECIFICATION ITEM NO.	DESCRIPTION
	<b>701</b>	<b>GENERAL STRUCTURES</b>
	701.1	STRUCTURAL WOOD PRODUCTS
	701.2	STRUCTURAL EXCAVATION
	701.3	STRUCTURAL BOLTING
	<b>702</b>	<b>CONCRETE STRUCTURES</b>
	702.1	DESCRIPTION
	702.2	CONCRETE STRUCTURE MATERIALS
(1)	702.3	MIX DESIGN AND MIXING CONCRETE FOR STRUCTURES
	702.4	MIX DESIGN AND MIXING LIGHTWEIGHT CONCRETE FOR STRUCTURES
	702.5	CONSTRUCTING CONCRETE STRUCTURES
	702.6	PRE-STRESSED CONCRETE FOR STRUCTURES
	702.7	PNEUMATICALLY PLACED CONCRETE (GUNITE)
	702.8	DRILLED SHAFT FOUNDATIONS
	702.9	PRE-CAST AND CAST-IN-PLACE CONCRETE UNITS
	<b>703</b>	<b>STEEL STRUCTURES</b>
	703.1	DESCRIPTION
	703.2	MATERIALS FOR STEEL STRUCTURES
	703.3	STEEL STRUCTURE CONSTRUCTION
	703.4	PAINTING METAL STRUCTURES
	703.5	MEASUREMENT AND PAYMENT
	<b>704</b>	<b>PILING</b>
	704.1	PILING MATERIALS
	704.2	DRIVING PILING
	704.3	PENETRATION
	704.4	BEARING RESISTANCE
	704.5	CONSTRUCTING CAST-IN-PLACE, PRE-STRESSED CONCRETE PILING
	704.6	MEASUREMENT AND PAYMENT

**ITEM 702 CONCRETE STRUCTURES**



702.3. MIX DESIGN AND MIXING CONCRETE FOR STRUCTURES

702.3.4. QUALITY OF CONCRETE

702.3.4.2. STANDARD CLASSES

*ADD THE FOLLOWING:*

Type “G” Concrete: Min.- Sacks Cement per C.Y. – 7.0; min. 28-day Comp. Strength - 5,000 PSI; Min. seven (7) day Strength 3600 PSI; Max. Water Cement Ratio - 5.0; Course Aggregate 1½-inch. No fly ash allowed.

**SECTION 7.08 | DIVISION 800. MISCELLANEOUS CONSTRUCTION AND MATERIALS**

*NOTE:* THE (1) SYMBOL SPECIFIES THAT THIS ITEM IS ALSO COVERED IN THE CITY OF ROCKWALL'S “SPECIAL PROVISIONS” TO THE “STANDARD SPECIFICATIONS FOR PUBLIC WORKS CONSTRUCTION, NORTH CENTRAL TEXAS”. THESE SPECIAL PROVISIONS ARE ADDITIONAL AND MODIFY THE “STANDARD SPECIFICATION”

**TABLE 7.8: REVISIONS TO NCTCOG'S DIVISION 800 MISCELLANEOUS CONSTRUCTION AND MATERIALS**

REVISED	STANDARD SPECIFICATION ITEM NO.	DESCRIPTION
	<b>801.</b>	<b>BARRIERS, WARNING &amp; DEOUR SIGNS AND FENCES</b>
	801.1.	BARRIERS AND WARNING AND DETOUR SIGNS
(1)	801.2.	METAL BEAM GUARD FENCE
	801.3.	RAILING
	801.4.	CHAIN LINK FENCE
(1)	801.5.	WIRE FENCE
	<b>802.</b>	<b>STEPS AND RETAINING WALLS</b>
	802.1.	CONCRETE STEPS
	802.2.	CONCRETE RETAINING WALLS
	802.3.	SEGMENTAL RETAINING WALL SYSTEMS
	802.4.	COFFERDAMS
	<b>803.</b>	<b>SLOPE AND CHANNEL PROTECTION</b>
	803.1.	ARTICULATING CONCRETE BLOCK
(1)	803.2.	GABION STRUCTURES
(1)	803.3.	RIPRAP
	803.4.	GEOTEXTILES USED IN DRAINAGE AND STABILIZATION APPLICATIONS
	<b>804.</b>	<b>PAINTING AND OTHER PROTECTIVE TREATMENTS; PAVEMENT MARKING</b>
	804.1.	DESCRIPTION
(2)	804.2.	PAINTING AND MARKING
	804.3.	GALVANIZING
	804.4.	MEASUREMENT AND PAYMENT
	804.5.	SPECIALTY COATINGS
	<b>805.</b>	<b>ELECTRICAL COMPONENTS AND CONDUIT</b>
	805.1.	DESCRIPTION
	805.2.	GENERAL REQUIREMENTS FOR ELECTRICAL COMPONENTS
(1)	805.3.	CONDUIT CONSTRUCTION METHODS
(1)	805.4.	MEASUREMENT AND PAYMENT
	<b>806.</b>	<b>METALS MATERIALS</b>
	806.1.	GENERAL
	806.2.	STRUCTURAL STEEL



806.3.	FORGINGS
806.4.	CASTINGS
806.5.	COPPER
806.6.	BOLTS, NUTS AND WASHERS
806.7.	MEASUREMENT AND PAYMENT

## ITEM 801 BARRIERS, WARNING & DETOUR SIGNS, AND FENCES

### 801.1. BARRIERS AND WARNING AND DETOUR SIGNS

#### *ADD THE FOLLOWING:*

Reflectorized marking for guard rail and other traffic control used shall meet the requirements of 3M Scotchlite Brand Reflective Sheeting Grade, Series 2800, 3800 or 5800, or equal. The marking shall conform to U.S. Department of Transportation, Federal Highway Administration, STANDARD SPECIFICATIONS FOR CONSTRUCTION OF ROADS AND BRIDGES ON FEDERAL HIGHWAY PROJECTS, 1979 FP-79, Type III A, Sections 633.36 and 718.01 and Federal Supply Service, General Services Administration, LS-300 C, SHEETING AND TAPE REFLECTIVE NON-EXPOSED LENS, Reflectivity 2, Class 4.

### 801.2. METAL BEAM GUARD FENCE

#### *ADD THE FOLLOWING:*

Reflectorized Marking shall be applied to metal beam guardrail at locations shown on the plans. To apply properly, the following equipment and accessories are recommended:

- (a) Heat Activated Adhesive
  - (1) Heat lamp vacuum applicator with temperature control.
  - (2) Remove protective liner from adhesive and place glossy side of liner over the sign face. Sheeting and liner may require perforation to aid in air evaluation.
- (b) Pressure Sensitive Adhesive
  - (1) 48-inch Interstate Squeeze Roll Applicator.
  - (2) Hand application. To obtain maximum initial adhesion use firm pressure with two (2) inch (*i.e. five [5] cm*) rubber roller or plastic squeeze. Multiple, heavy overlapping strokes should be used. Re-squeeze all edges.

### 801.5. WIRE FENCING

#### 801.5.2. MATERIAL

##### *ADD THE FOLLOWING:*

##### 801.5.2.1. WIRE FENCING FABRIC:

All chain link fencing shall be No. 9 gage copper bearing open-hearth steel wire.

##### 801.5.2.2. POSTS

##### 801.5.2.2.1 METAL POSTS

All posts shall be heavily galvanized by the hot-dip process after fabrication and shall be fitted with watertight malleable iron caps. All posts shall be of the following size and shape:

##### 801.5.2.2.2. LINE POSTS



“H” Section hot rolled weighing not less than 4.10 pounds per linear foot or 3½-inch O.D. pipe weighing not less than 3.65 pounds per linear foot.

801.5.2.2.3. TERMINAL POSTS

Three (3) inch steel pipe weighing not less than 5.79 pounds per linear foot.

801.5.2.2.4. GATE POSTS

Four (4) inch O.D. steel pipe weighing not less than 9.11 pounds per linear foot.

801.5.2.3. RAILS, GATES, BRACES AND FITTINGS

Shall be 1½-inch steel pipe weighing not less than 2.27 pounds per linear foot.

ITEM 803 SLOPE AND CHANNEL PROTECTION

803.2. GABION STRUCTURES

803.2.2. MATERIALS

803.2.2.1. BASKETS

*ADD THE SENTENCE:*

All wire used, including tie and connecting wire, shall be certified by Mill Test Reports showing compliance with specification requirements.

803.2.2.2. STONE

*ADD THE FOLLOWING:*

Facing stone shall be hand selected, large stone and shall be selected for best appearance. Facing stone shall be an off-white color and prior to laying the stone, samples shall be delivered to the site and shall be approved by the Engineer for gradation and appearance.

803.2.3. GABION CONSTRUCTION

803.2.3.1. GEOTEXTILE FILTER LAYER

*ADD THE FOLLOWING:*

High strength permeable barrier fabric for use as a filter media, shall be placed along the earth side of the Gabion Structures. The permeable barrier fabric to be used shall be TREVIRA S1115 as manufactured by Hoechst Fibers Industries, Spartanburg, South Carolina; MIRAFLI 140 Fabric, produced by Fiber Industries, Inc.; Bidim U-14 as distributed by Quline Corporation, Houston, Texas, or approved equal.

803.3. RIPRAP

803.3.2. RIPRAP MATERIALS

803.3.2.2. STONE

803.3.2.2.1. TYPES



Broken Concrete.

*DELETE THIS SUB-SECTION AND REPLACE WITH THE FOLLOWING WORDING:*

Broken concrete shall not be used for riprap.

## ITEM 804 PAINTING AND OTHER PROTECTIVE TREATMENTS, PAVEMENT MARKINGS

### 804.2 PAINTING AND MARKING

#### 804.2.3. PREPARING STRUCTURES FOR PAINT

##### 804.2.3.1. DESCALING, CLEANING AND PREPARATION OF SURFACES

*ADD THE FOLLOWING:*

Prior to painting concrete or masonry screening walls the concrete must be thoroughly cured and dry for proper adhesion of paint. Preparation of work shall include either of the following:

- (1) The concert surface shall be thoroughly washed with a solution of one (1) gallon Muriatic Acid to ten (10) gallons H<sub>2</sub>O (*Caution: Always add acid to H<sub>2</sub>O rather than H<sub>2</sub>O to acid*). Rinse thoroughly with clear water and paint while damp.
- (2) Treatment of surface with masonry conditioner such as a clear alkali-resistant soya alkyd binder type sealer or as recommended by paint manufacturer.

#### 804.2.5. PAINTING NEW STRUCTURES

##### 804.2.5.5. FINISH COATS

*ADD THE FOLLOWING:*

On masonry walls which are painted, the total dry film thickness shall be 6 mils (*two [2] coats applied at eight [8] mils wet and spreading rate = 200 square feet per gallon based on 36% + 2% Volume Solids*). The thickness shall be tested using a Wet Film Thickness Gage.

#### 804.2.6. CLEANING AND PAINTING EXISTING STRUCTURES

*ADD THE FOLLOWING:*

Masonry walls which require repainting shall be sand blasted or cleaned with a power brush, removing all mastic, powdery, thick layered, peeling or heavily chalked old paint. Spot prime all bare areas with Masonry Conditioner. If old paint is a cement-based paint, apply Masonry Conditioner to entire surface and apply two (2) coats of paint in accordance with 8.9.3(k) above.

## ITEM 805 ELECTRICAL COMPONENTS AND CONDUIT

### 805.3. MATERIAL

*ADD THE FOLLOWING:*

In the City of Rockwall, conduit for street lighting shall be 2-inch PVC pipe and for traffic control shall be three (3) inch PVC pipe, meeting the requirements of Item 2.10, Electrical Components.

*ADD THE FOLLOWING:*



#### 805.3.7. PULL BOX.

All pull boxes shall be #36 supplied by Traffic Signal Equipment Company, Fort Worth, Texas or approved equal. Boxes shall be approximately 10½-inch by 17-inch by 12-inch and shall be furnished with a concrete cover.

#### 805.4 CONDUIT CONSTRUCTION METHODS

*REVISE FIRST SENTENCE, THIRD PARAGRAPH TO READ AS FOLLOWS:*

All conduit shall be placed a minimum of 36-inches below finish grade. Conduit in median shall be placed a minimum of 36-inches below inside of curb as shown on plans.



## CHAPTER 8 | SPECIAL PROVISIONS TO THE NCTCOG'S STANDARD DRAWINGS FOR PUBLIC WORKS CONSTRUCTION STANDARDS

All work within the City of Rockwall shall conform to the standard drawings called out within this section. The City of Rockwall's Standard Drawing for Construction shall conform to Section II – Standard Drawings for North Central Texas Council of Governments Standard Specifications and Standard Drawings, November 2004, Fifth Edition.

The North Central Texas Standard Drawings shall be modified and clarified by the deletion, revision, and/or addition of the following drawings. Except when specifically stated, none of the standard drawings of the North Central Texas Standard Specifications shall be deleted.

### SECTION 8.01 | DIVISION 1000. EROSION AND SEDIMENT CONTROL

#### TABLE 8.1: DIVISION 1000 EROSION AND SEDIMENT CONTROL

NOTES: (1) DELETED NCTCOG DRAWING; (2) REVISED NCTCOG DRAWING (SEE REVISIONS BELOW); (3) ADDED ROCKWALL STANDARD DRAWING (SEE DRAWING BELOW); AND (4) ADDED CURRENT TXDOT STANDARDS

REVISED	DRAWING NO.	DESCRIPTION
	1010	RESERVED
(1)	1020A	SILT FENCE
(3)	R-1020A	SILT FENCE
(1)	1020B	SILT FENCE – GENERAL NOTES
(3)	R-1020B	SILT FENCE – GENERAL NOTES
	1030A	INTERCEPTOR SWALE
	1030B	INTERCEPTOR SWALE
	1040A	DIVERSION DIKE
	1040B	DIVERSION DIKE
	1050A	TRIANGULAR SEDIMENT FILTER DIKE
	1050B	TRIANGULAR SEDIMENT FILTER DIKE
	1060A	ROCK CHECK DAM
(1)	1060B	ROCK CHECK DAM
(3)	R-1060B	ROCK CHECK DAM
(1)	1070A	STABILIZED CONSTRUCTION ENTRANCE
(3)	R-1070A	STABILIZED CONSTRUCTION ENTRANCE
(1)	1070B	STABILIZED CONSTRUCTION ENTRANCE
(3)	R-1070B	STABILIZED CONSTRUCTION ENTRANCE
	1080A	SANDBAG CHECK DAM
	1080B	SANDBAG CHECK DAM
(1)	1090	STONE OUTLET – SEDIMENT TRAP
(3)	R-1090	STONE OUTLET – SEDIMENT TRAP
	1100	PIPE OUTLET – SEDIMENT BASIN
	1110	PIPE SLOPE DRAIN
	1120	INLET PROTECTION – FILTER BARRIER
(1)	1130	INLET PROTECTION-DROP – BLOCK AND GRAVEL
(1)	1140	INLET PROTECTION-CURB – BLOCK AND GRAVEL
	1150	INLET PROTECTION – EXCAVATED IMPOUNDMENT
	1160A	EROSION CONTROL BLANKETS
	1160B	EROSION CONTROL BLANKETS

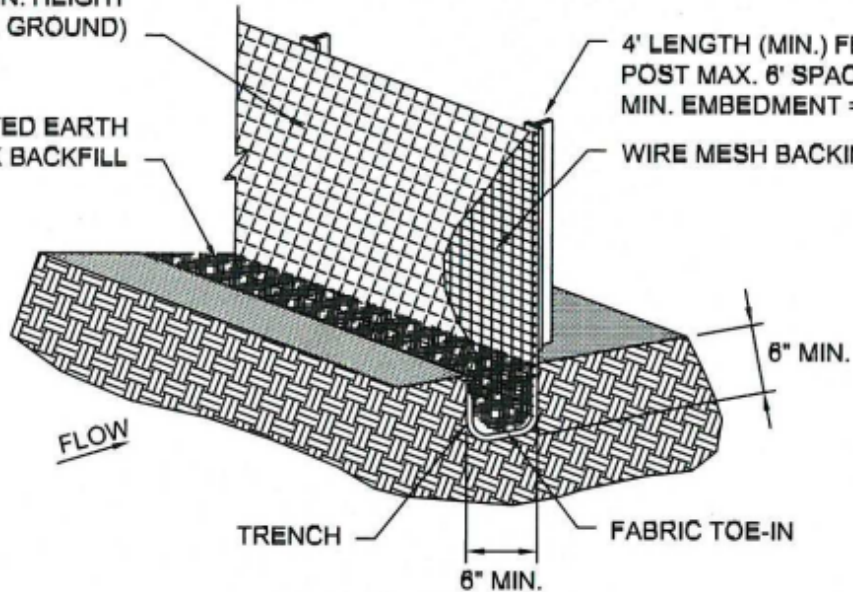


SILT FENCE (MIN. HEIGHT 24" ABOVE EXIST. GROUND)

COMPACTED EARTH OR ROCK BACKFILL

4' LENGTH (MIN.) FENCE POST MAX. 6' SPACING, MIN. EMBEDMENT = 1'

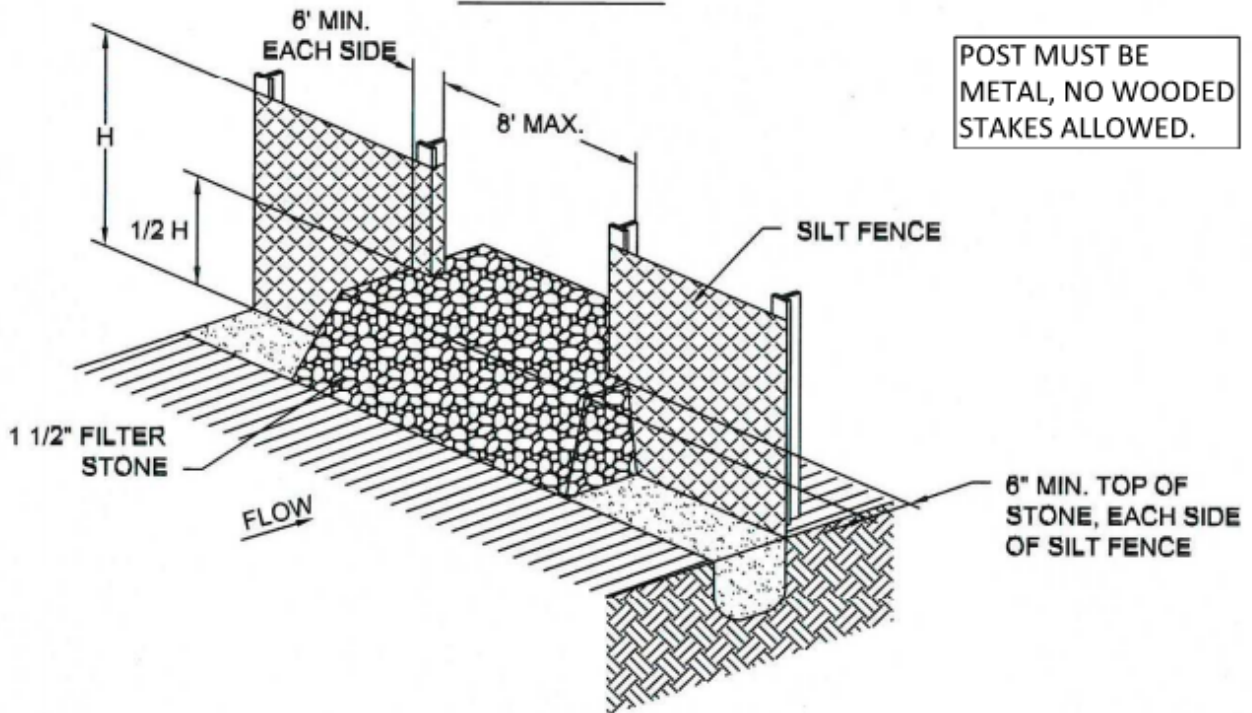
WIRE MESH BACKING



TRENCH 6" MIN. FABRIC TOE-IN 6" MIN.

**SILT FENCE**

POST MUST BE METAL, NO WOODED STAKES ALLOWED.



**STONE OVERFLOW STRUCTURE**

SILT FENCE

CITY OF ROCKWALL

STANDARD SPECIFICATION REFERENCE

202.5 \*



DATE

Mar. 2018

STANDARD DRAWING NO.


R-1020A





SILT FENCE GENERAL NOTES:


- 1. POSTS WHICH SUPPORT THE SILT FENCE SHALL BE INSTALLED ON A SLIGHT ANGLE TOWARD THE ANTICIPATED RUNOFF SOURCE. POST MUST BE EMBEDDED A MINIMUM OF ONE FOOT.
- 2. THE TOE OF THE SILT FENCE SHALL BE TRENCHED IN WITH A SPADE OR MECHANICAL TRENCHER, SO THAT THE DOWNSLOPE FACE OF THE TRENCH IS FLAT AND PERPENDICULAR TO THE LINE OF FLOW. WHERE FENCE CANNOT BE TRENCHED IN (e.g. PAVEMENT), WEIGHT FABRIC FLAP WITH ROCK ON UPHILL SIDE TO PREVENT FLOW FROM SEEPING UNDER FENCE.
- 3. THE TRENCH MUST BE A MINIMUM OF 6 INCHES DEEP AND 6 INCHES WIDE TO ALLOW FOR THE SILT FENCE FABRIC TO BE LAID IN THE GROUND AND BACKFILLED WITH COMPACTED MATERIAL.
- 4. SILT FENCE SHOULD BE SECURELY FASTENED TO EACH SUPPORT POST OR TO WIRE BACKING, WHICH IN TURN IS ATTACHED TO THE FENCE POST. THERE SHALL BE A 3 FOOT OVERLAP, SECURELY FASTENED WHERE ENDS OF FABRIC MEET.
- 5. INSPECTION SHALL BE AS SPECIFIED IN THE SWPPP. REPAIR OR REPLACEMENT SHALL BE MADE PROMPTLY AS NEEDED.
- 6. SILT FENCE SHALL BE REMOVED WHEN FINAL STABILIZATION IS ACHIEVED OR ANOTHER EROSION OR SEDIMENT CONTROL DEVICE IS EMPLOYED.
- 7. ACCUMULATED SILT SHALL BE REMOVED WHEN IT REACHES A DEPTH OF HALF THE HEIGHT OF THE FENCE. THE SILT SHALL BE DISPOSED OF AT AN APPROVED SITE AND IN SUCH A MANNER AS TO NOT CONTRIBUTE TO ADDITIONAL SILTATION.
- 8. FILTER STONE SHALL BE WRAPPED IN FILTER FABRIC AND BURIED SIX (6") INCHES MINIMUM.

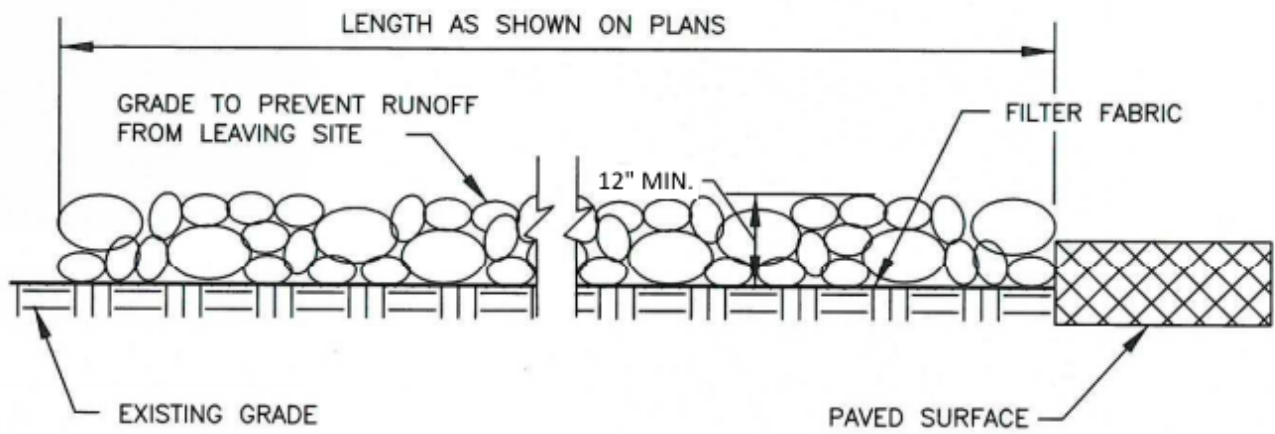
SILT FENCE	CITY OF ROCKWALL 	STANDARD SPECIFICATION REFERENCE 202.5 *	
		DATE Mar. 2018	STANDARD DRAWING NO. R-1020B



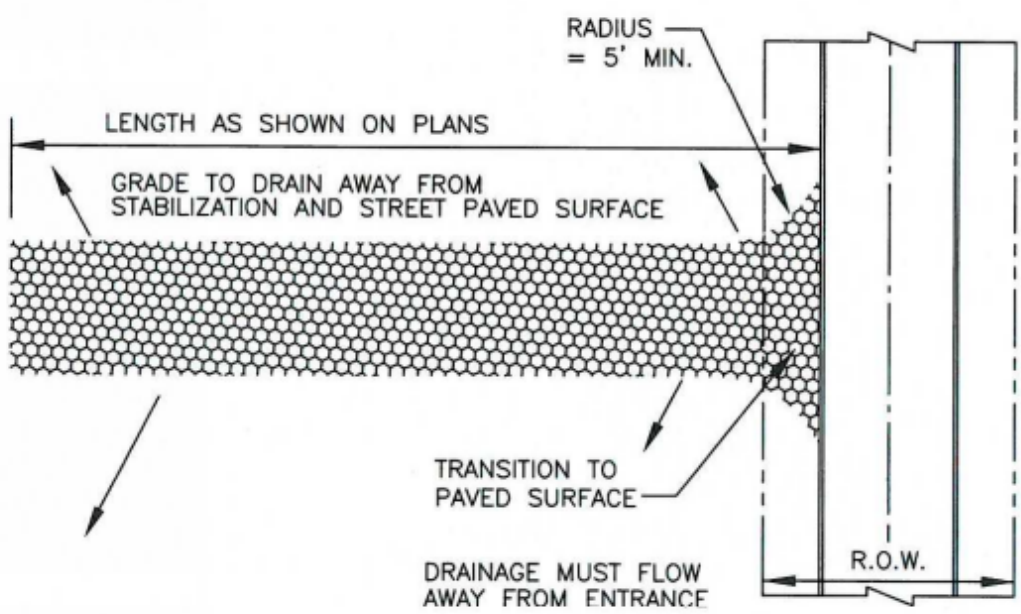
ROCK CHECK DAM GENERAL NOTES:

- 1. STONE SHALL BE WELL GRADED WITH SIZE RANGE FROM 1½ TO 3½ INCHES IN DIAMETER DEPENDING ON EXPECTED FLOWS.
- 2. THE CHECK DAM SHALL BE INSPECTED AS SPECIFIED IN THE SWPPP AND SHALL BE REPLACED WHEN THE STRUCTURE CEASES TO FUNCTION AS INTENDED DUE TO SILT ACCUMULATION AMONG THE ROCKS, WASHOUT, CONSTRUCTION TRAFFIC DAMAGE, ETC.
- 3. WHEN SILT REACHES A DEPTH EQUAL TO ONE-THIRD OF THE HEIGHT OF THE CHECK DAM OR ONE FOOT, WHICHEVER IS LESS, THE SILT SHALL BE REMOVED AND DISPOSED OF PROPERLY.
- 4. WHEN THE SITE HAS ACHIEVED FINAL STABILIZATION OR ANOTHER EROSION OR SEDIMENT CONTROL DEVICE IS EMPLOYED, THE CHECK DAM AND ACCUMULATED SILT SHALL BE REMOVED AND DISPOSED OF IN AN APPROVED MANNER.
- 5. FILTER STONE SHALL BE WRAPPED IN APPROPRIATE SIZED WIRE MESH TO CONTAIN STONE AND BURIED SIX (6") INCHES MINIMUM.

ROCK CHECK DAM	CITY OF ROCKWALL	STANDARD SPECIFICATION REFERENCE 202.9 *	
		DATE Mar. 2018	STANDARD DRAWING NO. R-1060B




PROFILE VIEW  
N.T.S.



PLAN VIEW  
N.T.S.


Note: No crushed concrete or recycled concrete allowed.

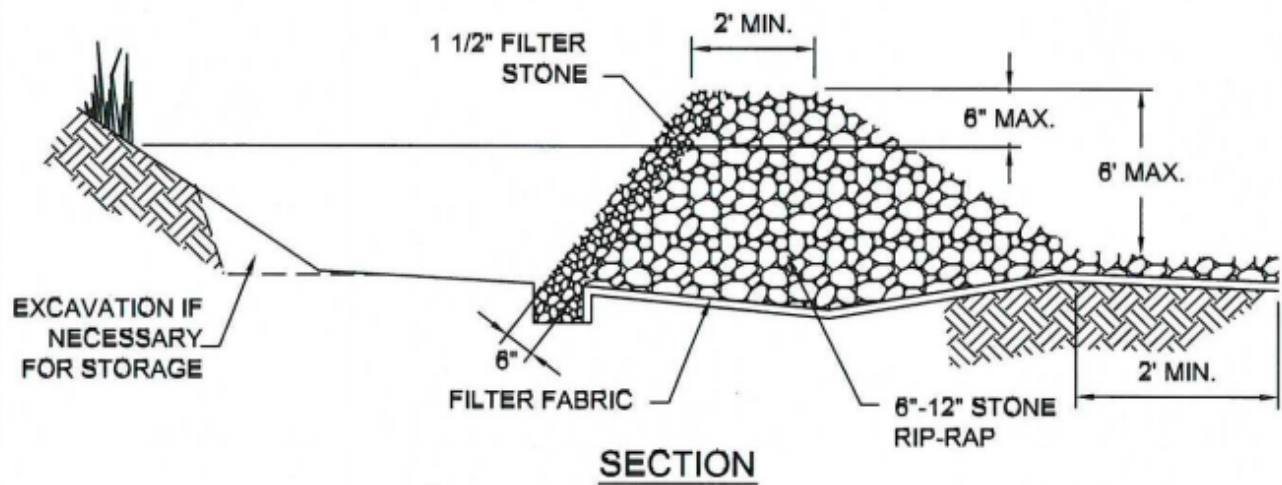
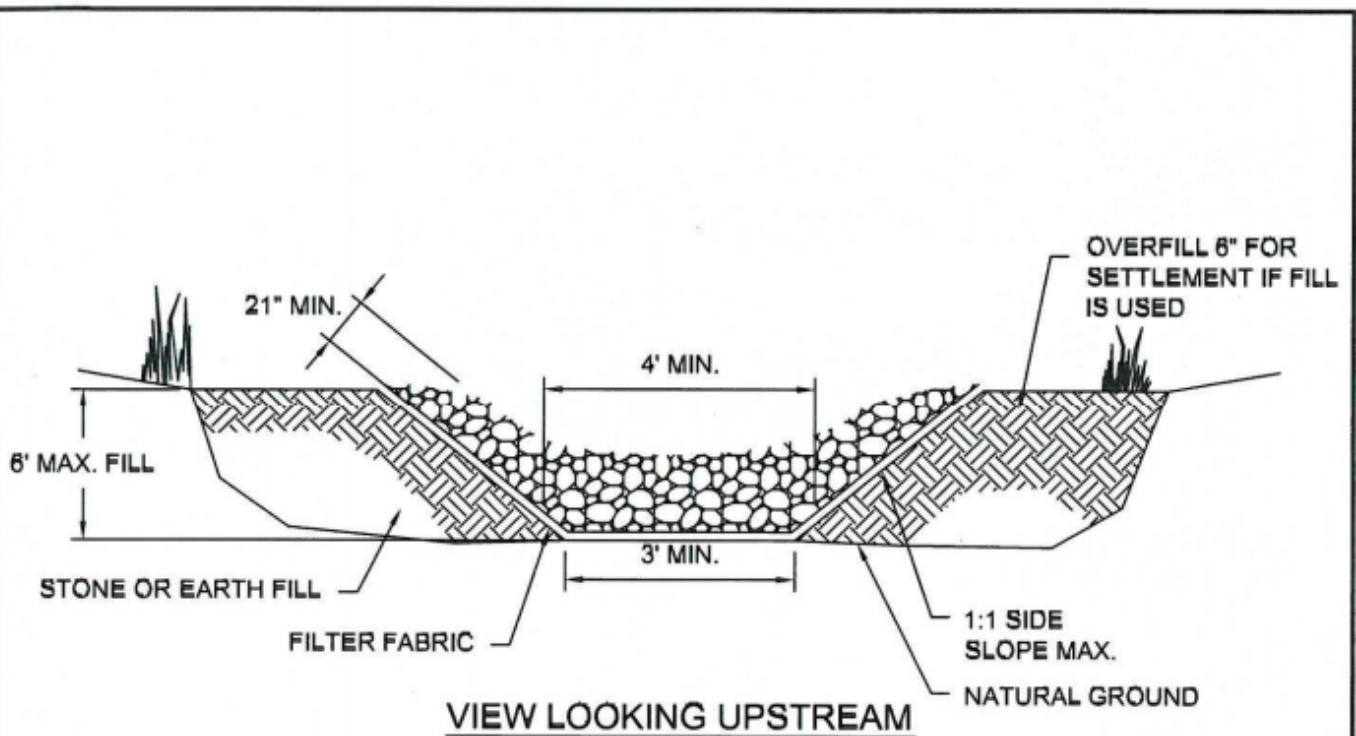
STABILIZED CONSTRUCTION ENTRANCE	CITY OF ROCKWALL 	STANDARD SPECIFICATION REFERENCE 202.11 *
		DATE: Mar. 2018 STANDARD DRAWING NO.: R-1070A




STABILIZED CONSTRUCTION ENTRANCE GENERAL NOTES:

1. STONE SHALL BE 4 TO 6 INCH DIAMETER COARSE AGGREGATE.
2. MINIMUM LENGTH SHALL BE 50 FEET AND WIDTH SHALL BE 20 FEET.
3. THE THICKNESS SHALL NOT BE LESS THAN 12 INCHES.
4. THE WIDTH SHALL BE NO LESS THAN THE FULL WIDTH OF ALL POINTS OF INGRESS OR EGRESS.
5. WHEN NECESSARY, VEHICLES SHALL BE CLEANED TO REMOVE SEDIMENT PRIOR TO ENTRANCE ONTO A PUBLIC ROADWAY. WHEN WASHING IS REQUIRED, IT SHALL BE DONE ON AN AREA STABILIZED WITH CRUSHED STONE WITH DRAINAGE FLOWING AWAY FROM BOTH THE STREET AND THE STABILIZED ENTRANCE. ALL SEDIMENT SHALL BE PREVENTED FROM ENTERING ANY STORM DRAIN, DITCH OR WATERCOURSE USING APPROVED METHODS.
6. THE ENTRANCE SHALL BE MAINTAINED IN A CONDITION WHICH WILL PREVENT TRACKING OR FLOWING OF SEDIMENT ONTO PAVED SURFACES. THIS MAY REQUIRE PERIODIC TOP DRESSING WITH ADDITIONAL STONE AS CONDITIONS DEMAND. ALL SEDIMENT SPILLED, DROPPED, WASHED, OR TRACKED ONTO PAVED SURFACES MUST BE REMOVED IMMEDIATELY.
7. THE ENTRANCE MUST BE PROPERLY GRADED OR INCORPORATE A DRAINAGE SWALE TO PREVENT RUNOFF FROM LEAVING THE CONSTRUCTION SITE.
8. PREVENT SHORTCUTTING OF THE FULL LENGTH OF THE CONSTRUCTION ENTRANCE BY INSTALLING BARRIERS AS NECESSARY.
9. INSPECTION SHALL BE AS SPECIFIED IN THE SWPPP.
10. NO CRUSHED OR RECYCLED CONCRETE ALLOWED.

STABILIZED CONSTRUCTION ENTRANCE	CITY OF ROCKWALL 	STANDARD SPECIFICATION REFERENCE 202.11 *	
		DATE Mar. 2018	STANDARD DRAWING NO. R-1070B



NOTE: FILTER STONE SHALL BE WRAPPED IN APPROPRIATE SIZED WIRE MESH TO CONTAIN STONE.

<p>STONE OUTLET SEDIMENT TRAP</p>	<p>CITY OF ROCKWALL</p> 	<p>STANDARD SPECIFICATION REFERENCE 202.12 *</p>	
		<p>DATE Mar. 2018</p>	<p>STANDARD DRAWING NO. R-1090</p>





## SECTION 8.02 | DIVISION 2000. PAVEMENT SYSTEMS

TABLE 8.2: REVISIONS TO NCTCOG'S DIVISION 2000 PAVEMENT SYSTEMS

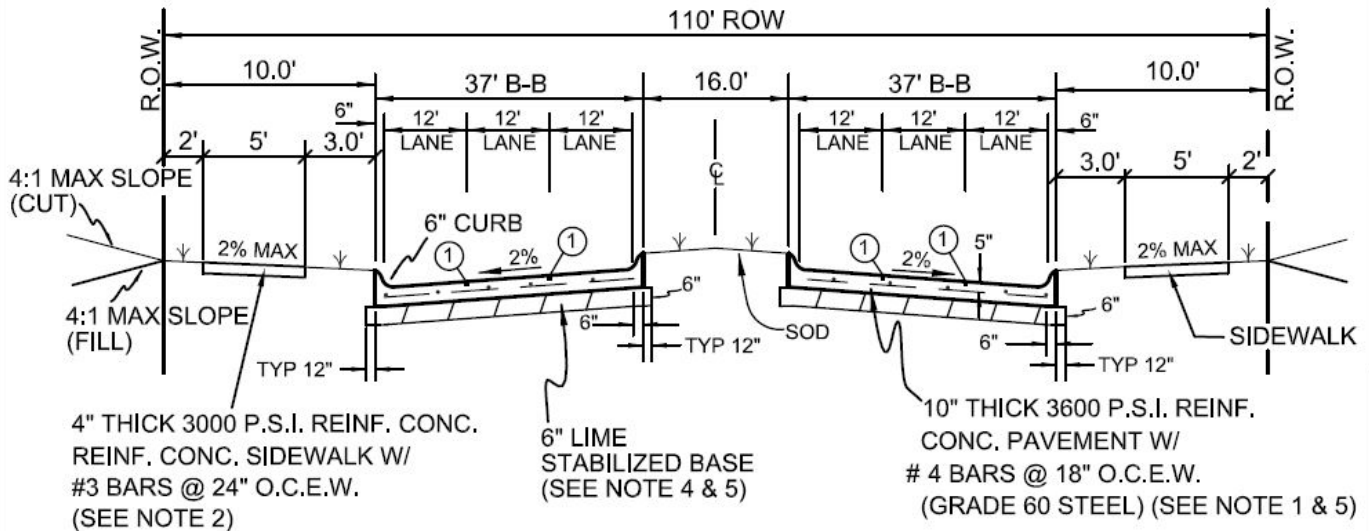
NOTES: (1) DELETED NCTCOG DRAWING; (2) REVISED NCTCOG DRAWING (SEE REVISIONS BELOW); (3) ADDED ROCKWALL STANDARD DRAWING (SEE DRAWING BELOW); AND (4) ADDED CURRENT TXDOT STANDARDS

REVISED	DRAWING NO.	DESCRIPTION
(1)	2010	REINFORCED CONCRETE PAVEMENT – SIX LANE DIVIDED THOROUGHFARE
(3)	R-2010	REINFORCED CONCRETE PAVEMENT – (P6D) PRINCIPAL ARTERIAL DIVIDED 6-LANE
(1)	2020	REINFORCED CONCRETE PAVEMENT – FOUR LANE DIVIDED THOROUGHFARE
(3)	R-2020	REINFORCED CONCRETE PAVEMENT – (A4D) MINOR ARTERIAL DIVIDED 4-LANE
(1)	2030	REINFORCED CONCRETE PAVEMENT – 2- & 4- UNDIVIDED THOROUGHFARE
(3)	R-2030	REINFORCED CONCRETE PAVEMENT – (M4U) MAJOR COLLECTOR UNDIVIDED 4-LANE
(3)	R-2031	REINFORCED CONCRETE PAVEMENT – MINOR COLLECTOR/LOCAL COMMERCIAL
(3)	R-2032	REINFORCED CONCRETE PAVEMENT – (M3U) MINOR COLLECTOR – 2 LANE WITH CONTINUOUS LEFT TURN LANE
(3)	R-2033	REINFORCED CONCRETE PAVEMENT – LOCAL RESIDENTIAL STREET
(1)	2040	REINFORCED CONCRETE PAVEMENT - ALLEYS
(3)	R-2040	REINFORCED CONCRETE PAVEMENT – ALLEYS
(3)	R-2041	REINFORCED CONCRETE PAVEMENT – FIRE LANE
(1)	2050	REINFORCED CONCRETE PAVEMENT - JOINTS
(3)	R-2050	REINFORCED CONCRETE PAVEMENT - JOINTS
(3)	R-2051	REINFORCED CONCRETE PAVEMENT – LONGITUDINAL BUTT JOINT
	2060	REINFORCED CONCRETE PAVEMENT – TRANSVERSE JOINT SPACING
(1)	2070	REINFORCED CONCRETE PAVEMENT – STREET HEADERS
(3)	R-2070	REINFORCED CONCRETE PAVEMENT – STREET HEADERS
	2080	REINFORCED CONCRETE PAVEMENT – BRIDGE APPROACH SLAB
(1)	2090	HOT MIX ASPHALT PAVEMENT – SIX LANE DIVIDED THOROUGHFARE
(1)	2100	HOT MIX ASPHALT PAVEMENT – FOUR LANE DIVIDED THOROUGHFARE
(1)	2110	HOT MIX ASPHALT PAVEMENT – 2- & 4- UNDIVIDED THOROUGHFARE
	2120	CONCRETE CURB AND GUTTER – INTEGRAL, SEPARATE, AND DOWELED
(1)	2125A - 2125B	CURB RAMPS
(3)	R-2125A - R-2125D	DIRECTIONAL CURB RAMP
(4)		TXDOT: PED-18: PEDESTRIAN FACILITIES – CURB RAMPS
(1)	2130	MEDIAN ISLAND PAVEMENT – NOSE & LEFT TURN LANE
(3)	R-2130	MEDIAN ISLAND PAVEMENT – NOSE & LEFT TURN LANE
(1)	2140	MEDIAN ISLAND PAVEMENT – MONOLITHIC CONCRETE NOSE
(3)	R-2140	MEDIAN ISLAND PAVEMENT – MONOLITHIC CONCRETE NOSE
(1)	2150A - 2150B	DRIVEWAY APPROACH – FLARED RETURN TYPE
(1)	2155	DRIVEWAY APPROACH – RADIUS RETURN TYPE
(3)	R-2150	DRIVEWAY DETAIL – RESIDENTIAL DRIVEWAY
(3)	R-2151A	RESIDENTIAL DRIVEWAY – SIDEWALK ADJACENT TO CURB – HIGH SIDE OF THE STREET
(3)	R-2151B	RESIDENTIAL DRIVEWAY – SIDEWALK ADJACENT TO CURB – HIGH SIDE OF THE STREET
(3)	R-2152	RESIDENTIAL DRIVEWAY – SIDEWALK ADJACENT TO CURB – DRIVEWAYS CLOSER THAN 27-FT
(1)	2160	ALLEY APPROACH – RADIUS RETURN TYPE
(3)	R-2160	ALLEY APPROACH – RADIUS RETURN TYPE
(1)	2170	REINFORCED CONCRETE SIDEWALKS – JOINTS AND SPACING
(3)	R-2170	REINFORCED CONCRETE SIDEWALKS – JOINTS AND SPACING
(1)	2180	REINFORCED CONCRETE RETAINING WALL - INTEGRAL WITH SIDEWALK
(3)	R-2180	REINFORCED CONCRETE RETAINING WALL - INTEGRAL WITH SIDEWALK
(1)	2190	PAVEMENT SYSTEMS – GENERAL NOTES
(3)	R-2190	PAVEMENT SYSTEMS – GENERAL NOTES
	2200	SUBDRAINS – PAVEMENT SUBGRADE
(1)	2210	ALLEY GEOMETRICS – TYPE “A”: & TYPE “B”
(3)	R-2210	ALLEY GEOMETRICS – TYPE “A”: & TYPE “B”
(1)	2220	ALLEY GEOMETRICS - TYPE “C”: & TYPE “D”



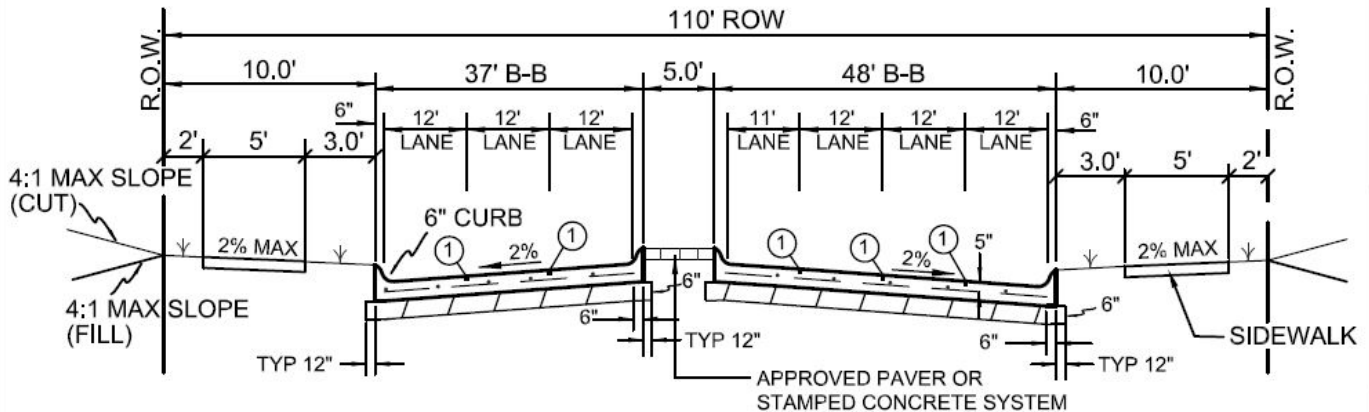
(3)	R-2220	ALLEY GEOMETRICS - TYPE "C": & TYPE "D"
(1)	2230	ALLEY GEOMETRICS - TYPE "E": & TYPE "F"
(3)	R-2230	ALLEY GEOMETRICS - TYPE "E": & TYPE "F"
(1)	2240	ALLEY GEOMETRICS - TYPE "G": & TYPE "H"
(3)	R-2240	ALLEY GEOMETRICS - TYPE "G": & TYPE "H"
(1)	2250	ALLEY GEOMETRICS - TYPE "J"
(3)	R-2250	ALLEY GEOMETRICS - TYPE "J"
(3)	R-2251	ALLEY GEOMETRICS – ALLEY WARPING AT INLET
	2260	ALLEY INTERSECTION – PROPOSED TO EXISTING
(3)	R-2270	LEFT TURN LANE – CONCRETE REMOVAL & REPLACEMENT
(1)	2270A	METAL BEAM GUARD FENCE – ROADSIDE PLACEMENT & BEAM ELEMENTS
(1)	2270B	METAL BEAM GUARD FENCE – LINE POST & CONNECTIONS
(1)	2270C	METAL BEAM GUARD FENCE – END SECTION & ANGLE ANCHOR POST
(1)	2270D	METAL BEAM GUARD FENCE – SPECIAL END SHOE & ANCHOR POST
(1)	2270E	METAL BEAM GUARD FENCE – GENERAL NOTES
(1)	2280A	METAL BEAM GUARD FENCE – TWO-WAY TRAFFIC BRIDGE END
(1)	2280B	METAL BEAM GUARD FENCE – TWO-WAY TRAFFIC BRIDGE END
(4)		TXDOT: METAL BEAM GUARD FENCE
	2290	METAL BEAM GUARD FENCE – END OF ROAD
(3)	R-2300	STREET REGULATORY SIGN - STREET NAME BLADES
(3)	R-2310	ILLUMINATED STREET NAME SIGN – ILSN SIGN DETAIL
(3)	R-2320	RAISED PAVEMENT MARKINGS – LANE LINES
(3)	R-2330	RAISED PAVEMENT MARKINGS – CHEVRON AND CROSSHATCH
(3)	R-2340	RAISED PAVEMENT MARKINGS – INTERSECTION APPROACH
(3)	R-2350	TYPE C INTERSECTION – RIGHT LANE DROP MARKINGS
(3)	R-2360	TYPICAL THOROUGHFARE LAYOUTS
(3)	R-2370	TYPICAL CROSSWALK LAYOUTS
(3)	R-2380	TYPICAL CROSSWALK AND DASHED MARKINGS
(3)	R-2390	CHEVRON STRIPING
(3)	R-2400	DIAGONAL CROSSHATCH STRIPING





**110' ROW – Principal 6 Lane  
Divided Arterial  
Regular Section  
(Not to Scale)**

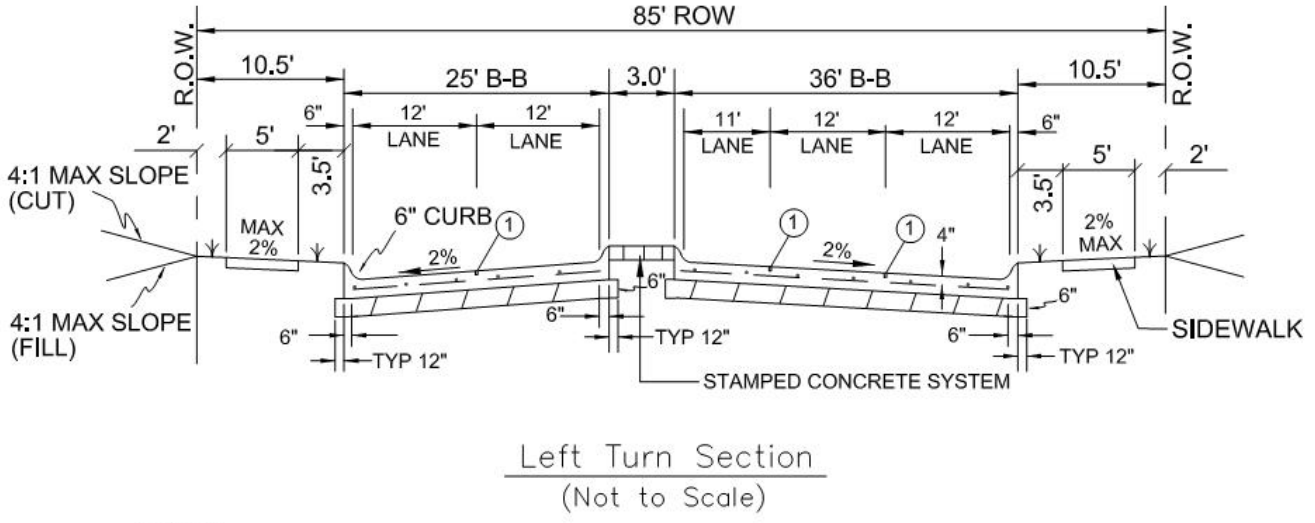
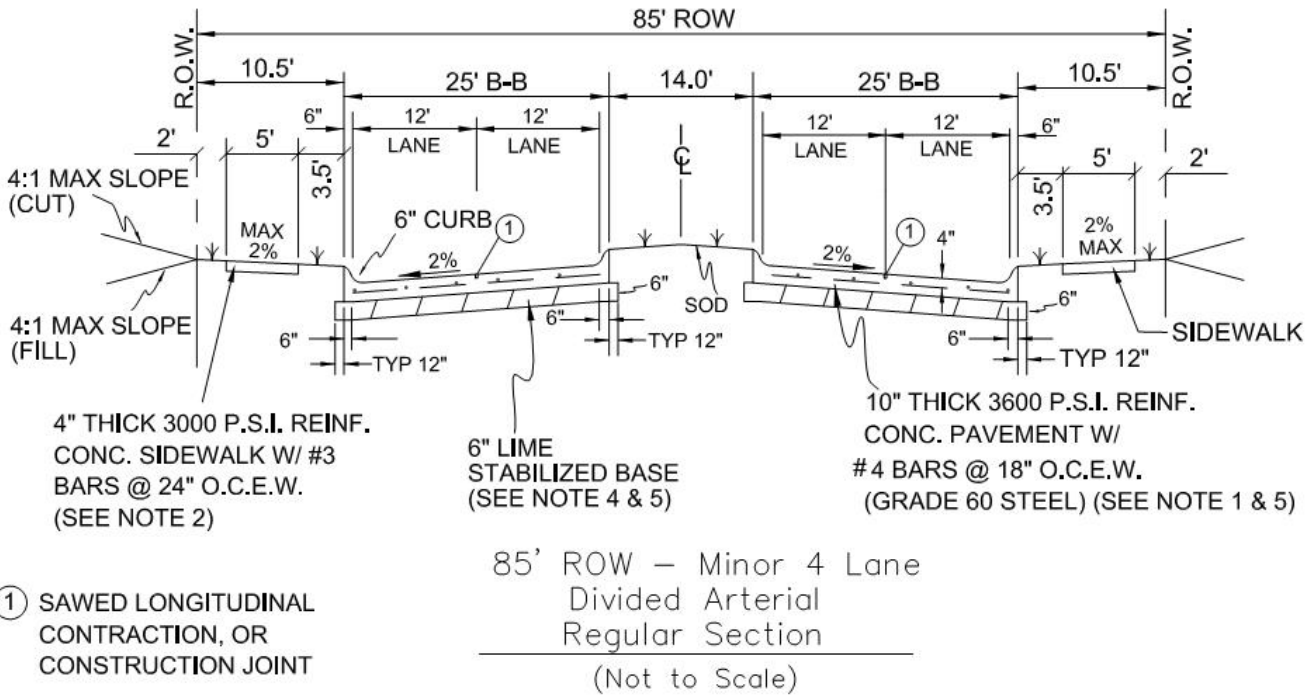
- ① SAWED LONGITUDINAL CONTRACTION, OR CONSTRUCTION JOINT




**NOTES:**

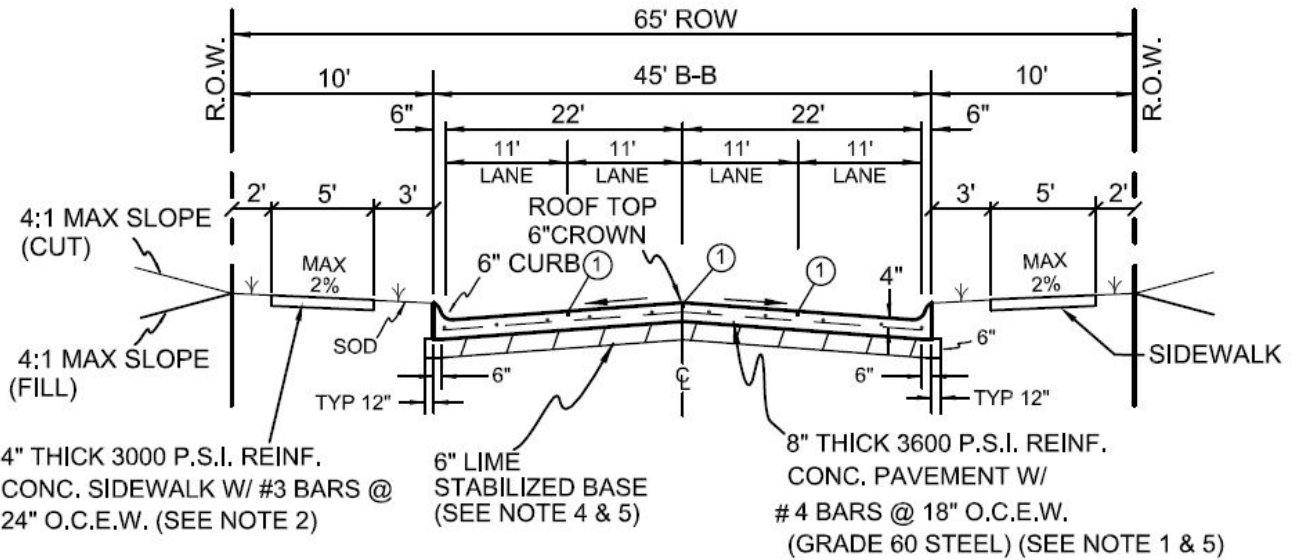
1. Street pavement cement content to be no less than 6.0 sacks per cubic yard for machine placed and not less than 6.5 sacks per cubic yard for hand placed.
2. Sidewalk Cement content of not less than 5.5 sack per cubic yard.
3. No sand allowed under pavement or sidewalks.
4. Minimum lime content shall be 6% of dry weight of material (at least 27 lbs/SY) compact to 95% standard density.
5. Paving Section design shall be based off the 30 year projected traffic volumes and geotechnical analysis/report.

<b>REINFORCED CONCRETE PAVEMENT</b>	<b>CITY OF ROCKWALL</b>		
(P6D) PRINCIPAL ARTERIAL DIVIDED 6-LANE		DATE <b>AUG. '15</b>	DRAWING NO. <b>R-2010</b>



- NOTES:**
1. Street pavement cement content to be no less than 6 sacks per cubic yard for machine placed and not less than 6.5 sacks per cubic yard for hand placed.
  2. Sidewalk Cement content of not less than 5.5 sack per cubic yard.
  3. No sand allowed under pavement or sidewalks.
  4. Minimum lime content shall be 6% of dry weight of material (at least 27 lbs/SY) compacted to 95% standard density.
  5. Paving Section design shall be based off the 30 year projected traffic volumes and geotechnical analysis/report.

REINFORCED CONCRETE PAVEMENT	CITY OF ROCKWALL	
(A4D) MINOR ARTERIAL DIVIDED 4-LANE		DATE AUG. '22
		DRAWING NO. R-2020




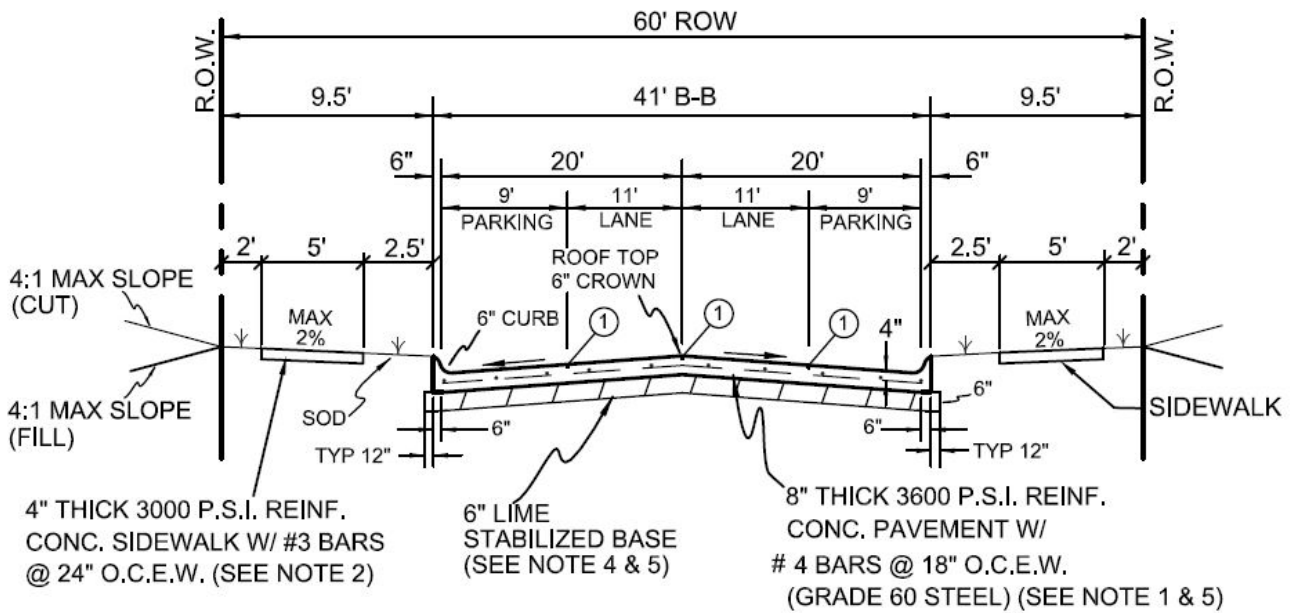
① SAWED LONGITUDINAL  
CONTRACTION, OR  
CONSTRUCTION JOINT

**65' ROW – Major 4 Lane  
Undivided Collector**  
(Not to Scale)

**NOTES:**

1. Street pavement cement content to be no less than 6 sacks per cubic yard for machine placed and not less than 6.5 sacks per cubic yard for hand placed.
2. Sidewalk Cement content of not less than 5.5 sack per cubic yard.
3. No sand allowed under pavement or sidewalks.
4. Minimum lime content shall be 6% of dry weight of material (at least 27 lbs/SY) compacted to 95% standard density.
5. Paving Section design shall be based off 30 year projected traffic volumes and geotechnical analysis/report.

<b>REINFORCED CONCRETE PAVEMENT</b>	<b>CITY OF ROCKWALL</b>		
(M4U) MAJOR COLLECTOR UNDIVIDED 4-LANE		DATE <b>AUG. '15</b>	DRAWING NO. <b>R-2030</b>



4" THICK 3000 P.S.I. REINF. CONC. SIDEWALK W/ #3 BARS @ 24" O.C.E.W. (SEE NOTE 2)

6" LIME STABILIZED BASE (SEE NOTE 4 & 5)

8" THICK 3600 P.S.I. REINF. CONC. PAVEMENT W/ # 4 BARS @ 18" O.C.E.W. (GRADE 60 STEEL) (SEE NOTE 1 & 5)

① SAWED LONGITUDINAL CONTRACTION, OR CONSTRUCTION JOINT

**60' ROW – Minor Collector and or Local Commercial**

(Not to Scale)

**NOTES:**

1. Street pavement cement content to be no less than 6 sacks per cubic yard for machine placed and not less than 6.5 sacks per cubic yard for hand placed.
2. Sidewalk Cement content of not less than 5.5 sack per cubic yard.
3. No sand allowed under pavement or sidewalks.
4. Minimum lime content shall be 6% of dry weight of material (at least 27 lbs/SY) compacted to 95% standard denslty.
5. Paving Section design shall be based off the 30 year traffic volumes and geotechnical analysis/report.

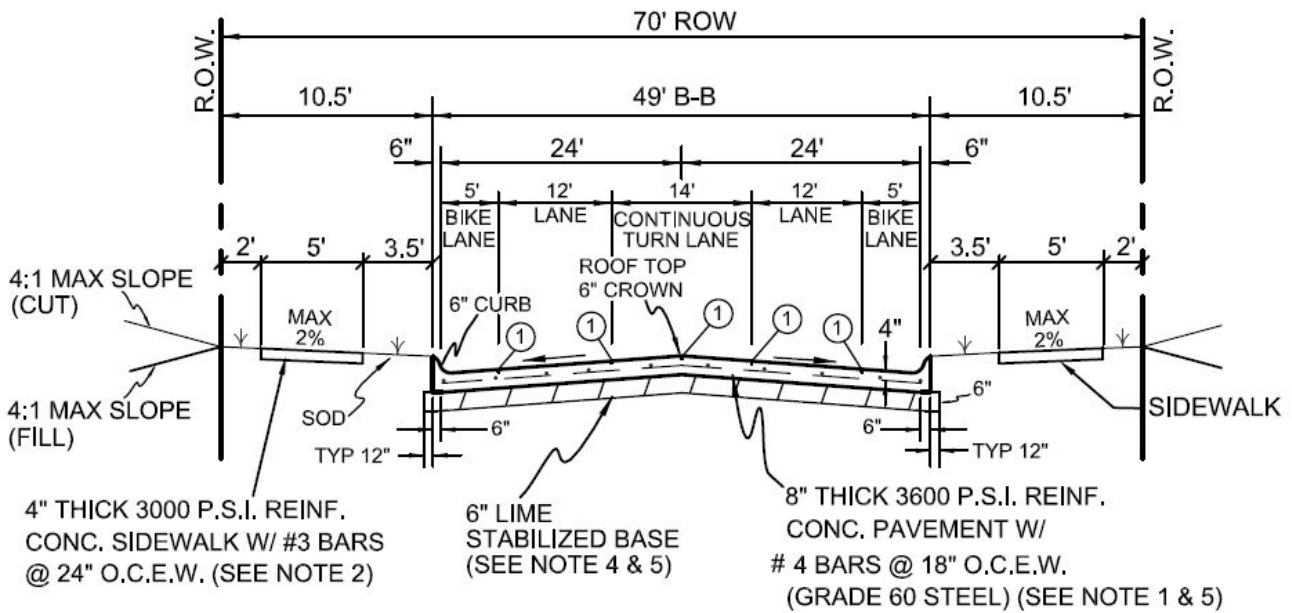
**REINFORCED CONCRETE PAVEMENT**

**CITY OF ROCKWALL**

MINOR COLLECTOR/LOCAL COMMERCIAL



DATE	DRAWING NO.
AUG. '15	R-2031



4" THICK 3000 P.S.I. REINF. CONC. SIDEWALK W/ #3 BARS @ 24" O.C.E.W. (SEE NOTE 2)

6" LIME STABILIZED BASE (SEE NOTE 4 & 5)

8" THICK 3600 P.S.I. REINF. CONC. PAVEMENT W/ # 4 BARS @ 18" O.C.E.W. (GRADE 60 STEEL) (SEE NOTE 1 & 5)

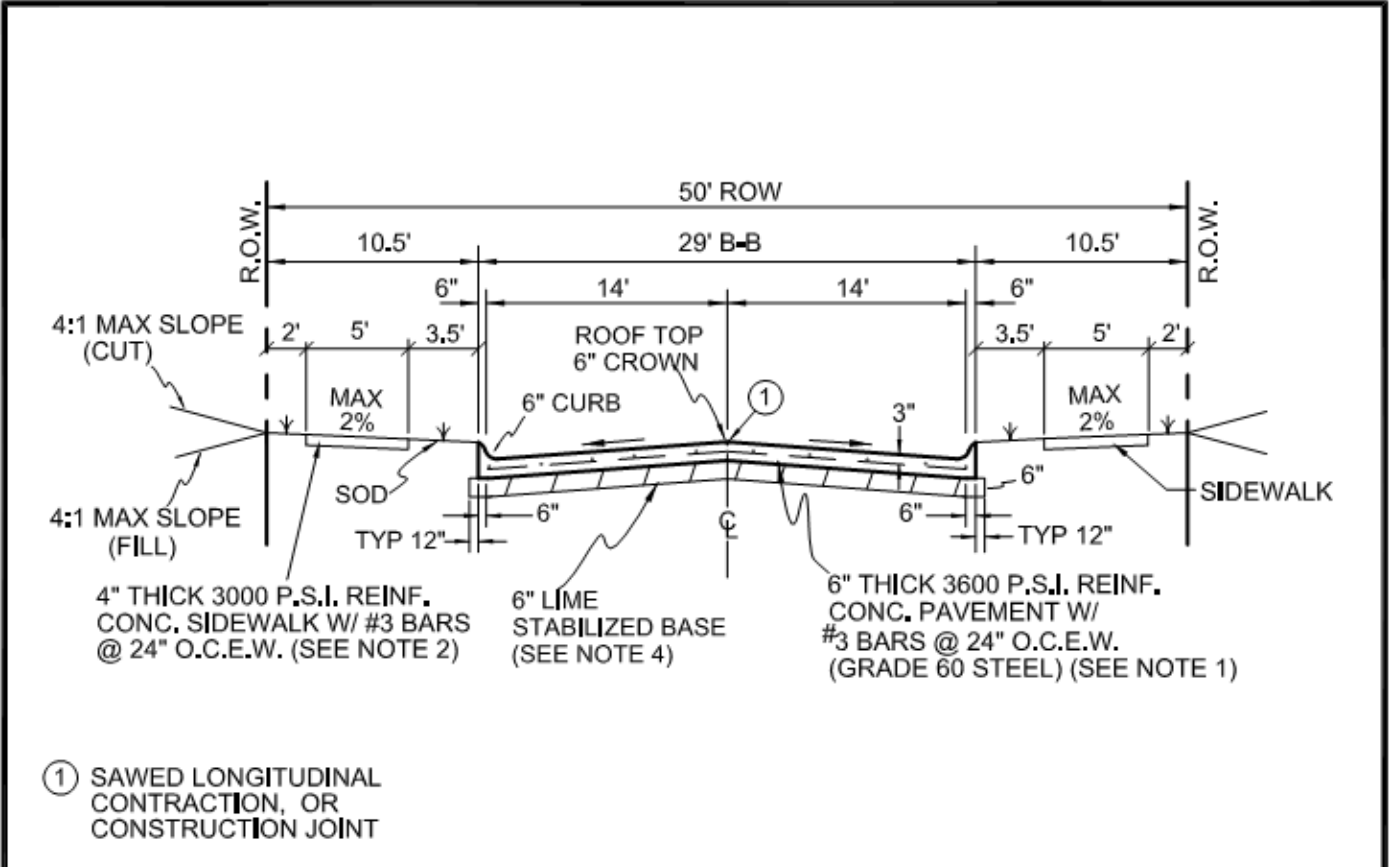
① SAWED LONGITUDINAL CONTRACTION, OR CONSTRUCTION JOINT

**70' ROW – Minor Collector  
2 Lane with Continuous Left Turn Lane  
(Not to Scale)**

NOTES:

1. Street pavement cement content to be no less than 6 sacks per cubic yard for machine placed and not less than 6.5 sacks per cubic yard for hand placed.
2. Sidewalk Cement content of not less than 5.5 sack per cubic yard.
3. No sand allowed under pavement or sidewalks.
4. Minimum lime content shall be 6% of dry weight of material (at least 27 lbs/SY) compacted to 95% standard density.
5. Paving Section design shall be based off the 30 year projected traffic volumes and geotechnical analysis/report.


<b>REINFORCED CONCRETE PAVEMENT</b>		<b>CITY OF ROCKWALL</b>	
(M3U) MINOR COLLECTOR – 2 LANE WITH CONTINUOUS LEFT TURN LANE			
		DATE <b>AUG. '15</b>	DRAWING NO. <b>R-2032</b>

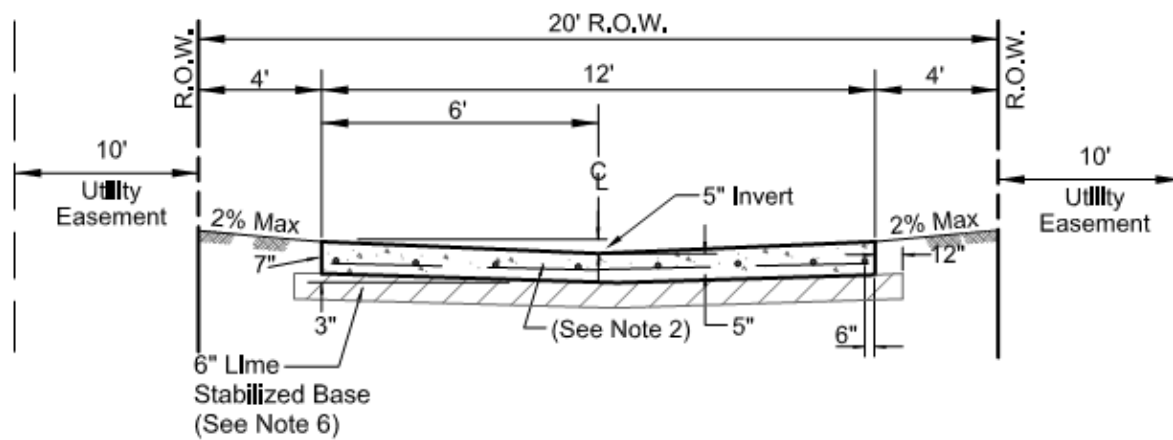


**50' R.O.W. Residential Street**  
(Not to Scale)

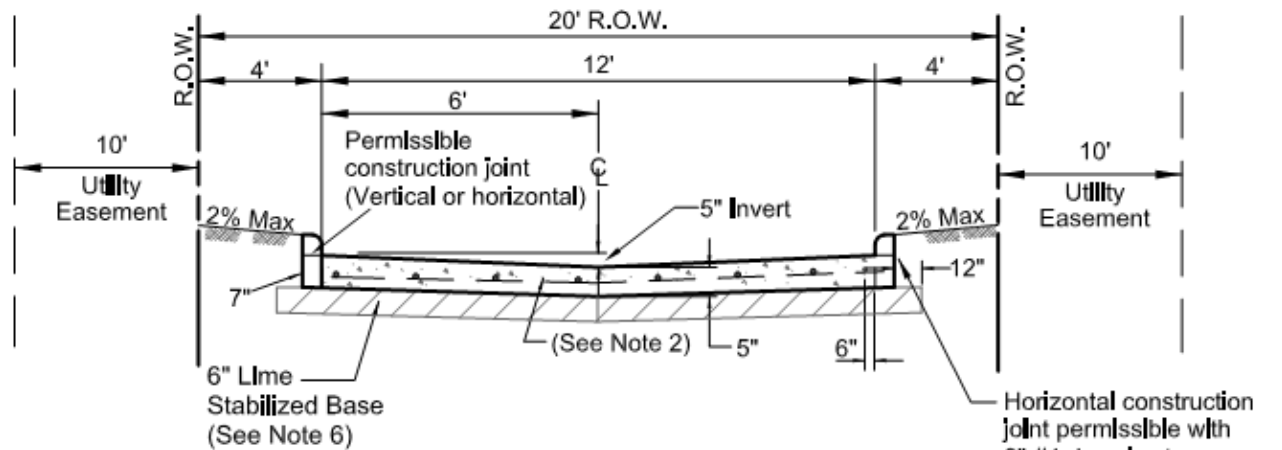
**NOTES:**

1. Street pavement cement content to be no less than 6 sacks per cubic yard for machine placed and not less than 6.5 sacks per cubic yard for hand placed.
2. Sidewalk Cement content of not less than 5.5 sack per cubic yard.
3. No sand allowed under pavement or sidewalks.
4. Minimum lime content shall be 6% of dry weight of material (at least 27 lbs/SY) compacted to 95% standard density.

REINFORCED CONCRETE PAVEMENT	CITY OF ROCKWALL 	DATE	DRAWING NO.
LOCAL RESIDENTIAL STREET		AUG. '19	R-2033



**ALLEY SECTION WITHOUT CURB**  
(Not to Scale)

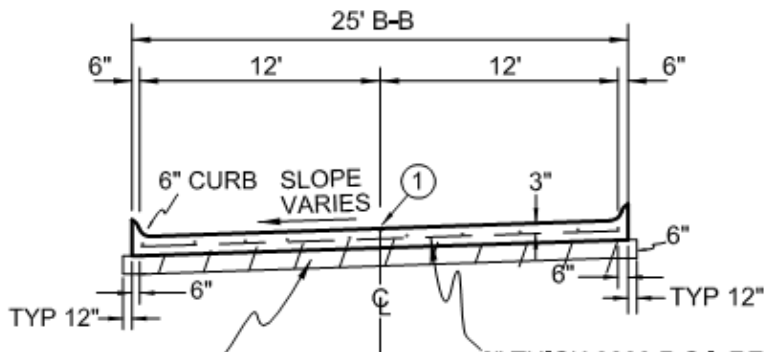


**ALLEY SECTION WITH CURB**  
(Not to Scale)

**NOTES:**

1. Provide sawed transverse contraction joints not more than 20' C-C.
2. Reinforced with no. 3 bars at 24" C-C both ways.
3. Expansion joints to be placed at all intersections and not to exceed 600' between joints.
4. Concrete shall be 7"-5"-7" Thick 3,600 P.S.I., Alley cement content shall be min. 6.0 sack for machine placed and 6.5 sack mix for hand placed.
5. No sand allowed under pavement.
6. Minimum lime content shall be 6% of dry weight of material (at least 27 lbs/SY) compacted to 95% standard density.

<b>REINFORCED CONCRETE PAVEMENT</b>	<b>CITY OF ROCKWALL</b>		
<b>ALLEYS</b>		DATE <b>AUG '19</b>	DRAWING NO. <b>R-2040</b>



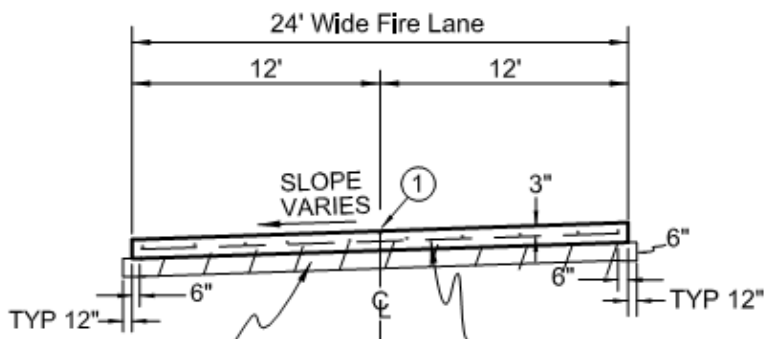
6" THICK, NATIVE OR SELECT MATERIAL COMPACTED TO 95% STANDARD PROCTOR DENSITY

6" THICK 3600 P.S.I. REINF. CONC. PAVEMENT W/ #3 BARS @ 24" O.C.E.W. (GRADE 60 STEEL) (SEE NOTE 1)

**24' Wide Fire Lane with Curbs**

(Not to Scale)

① SAWED LONGITUDINAL CONTRACTION OR CONSTRUCTION JOINT



6" THICK, NATIVE OR SELECT MATERIAL COMPACTED TO 95% STANDARD PROCTOR DENSITY

6" THICK 3600 P.S.I. REINF. CONC. PAVEMENT W/ #3 BARS @ 24" O.C.E.W. (GRADE 60 STEEL) (SEE NOTE 1)

**24' Wide Fire Lane**

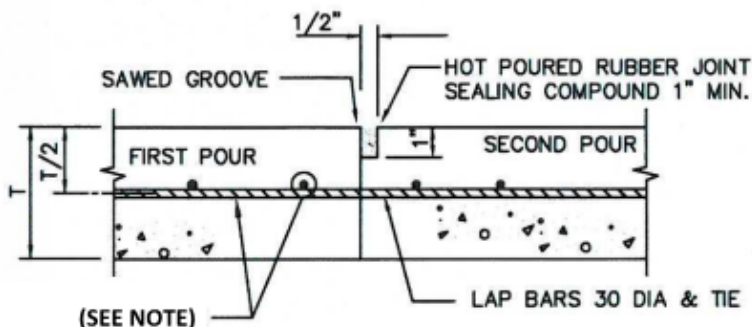
(Not to Scale)

**NOTES:**

1. Street pavement cement content to be no less than 6 sacks per cubic yard for machine placed and not less than 6.5 sacks per cubic yard for hand placed.
2. Sidewalk Cement content of not less than 5.5 sack per cubic yard.
3. No sand allowed under pavement or sidewalks.

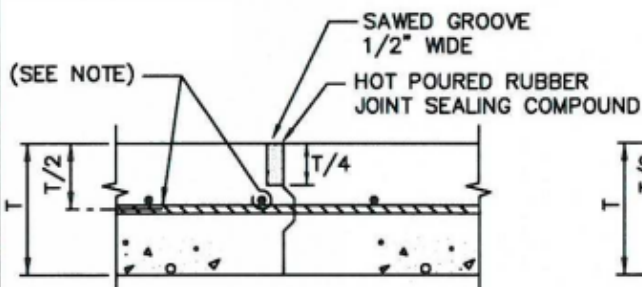
REINFORCED CONCRETE PAVEMENT	CITY OF ROCKWALL		
FIRE LANE		DATE AUG. '19	DRAWING NO. R-2041





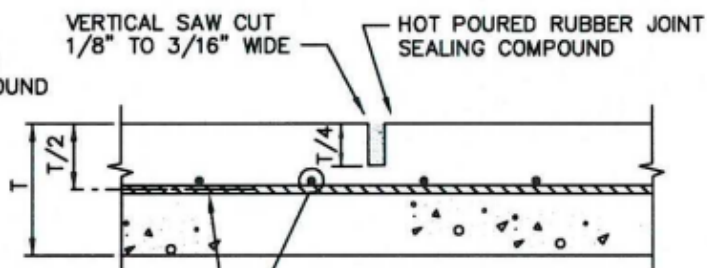
**CONSTRUCTION JOINT**

N.T.S.



**KEYWAY JOINT**

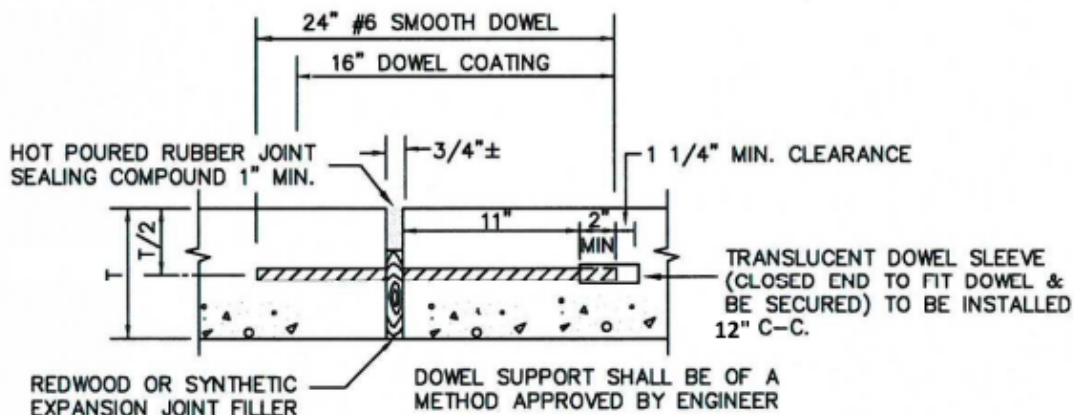
(FOR PAVEMENT THICKNESS > 6")  
N.T.S.



**SAWED CONTRACTION JOINT**

N.T.S.

**NOTE:**  
REINFORCING SHALL BE - #3 BARS AT 24" FOR 6"  
THICK PAVEMENT AND LESS. #4 BARS AT 18"  
FOR 8" THICK PAVEMENT AND GREATER.



**EXPANSION JOINT**

(SPACED 600 FT. MAXIMUM; LOCATE AT  
STRUCTURES AND AT INTERSECTION P.C.'S & P.T.'S)  
N.T.S.

REINFORCED CONCRETE PAVEMENT

CITY OF ROCKWALL

STANDARD SPECIFICATION REFERENCE

303.5.4.

JOINTS

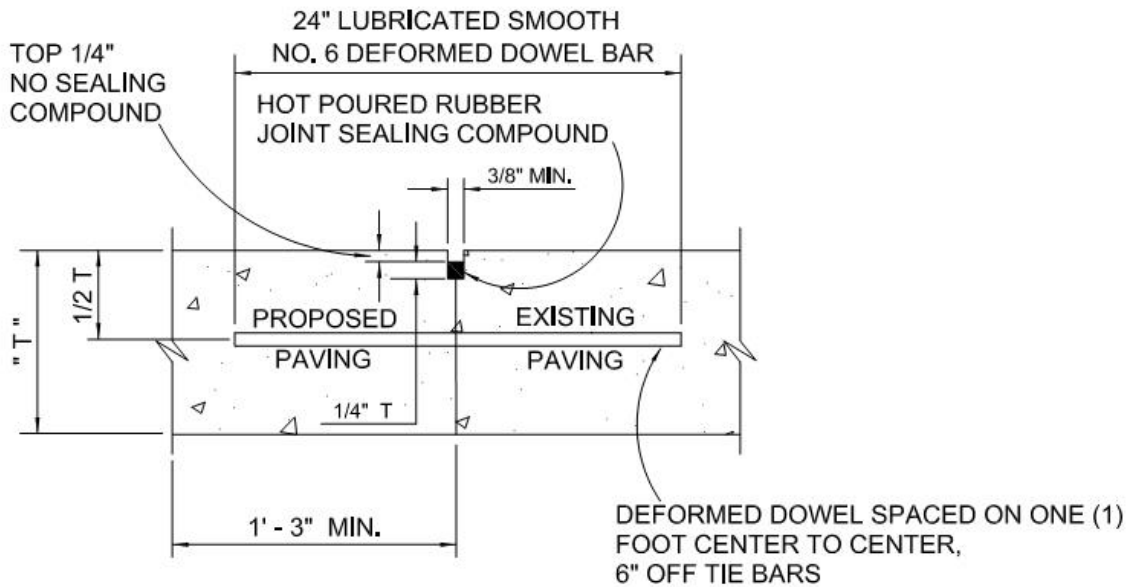


DATE

Mar. 2018

STANDARD DRAWING NO.


R-2050

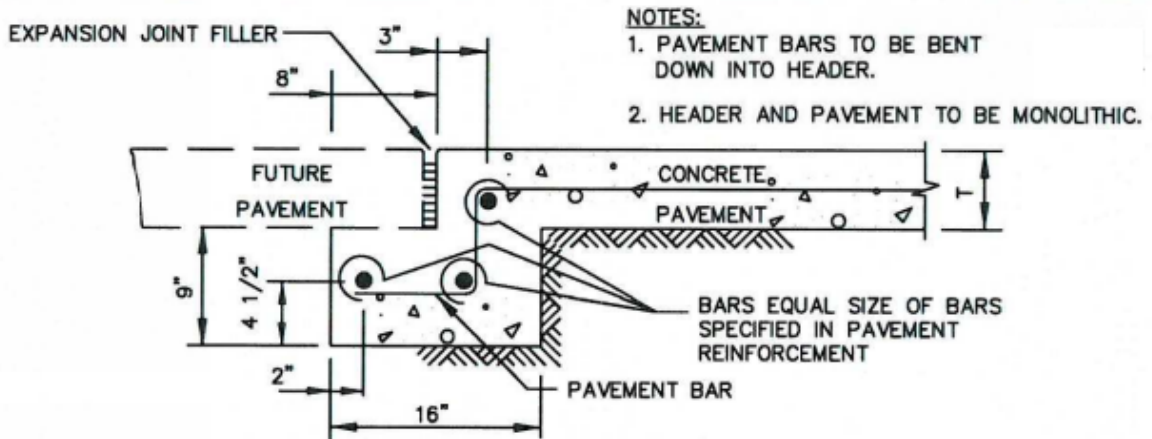


NOTES: T = PAVEMENT

1. LONGITUDINAL BUTT CONSTRUCTION MAY BE UTILIZED IN PLACE OF LONGITUDINAL HINGED (KEYWAY) JOINT AT CONTRACTORS OPTION.
2. DEFORMED DOWEL BARS SHALL BE DRILLED INTO PAVEMENT HORIZONTALLY BY USE OF A MECHANICAL RIG.
3. DRILLING BY HAND IS NOT ACCEPTABLE, PUSHING DOWEL BARS INTO GREEN CONCRETE NOT ACCEPTABLE.

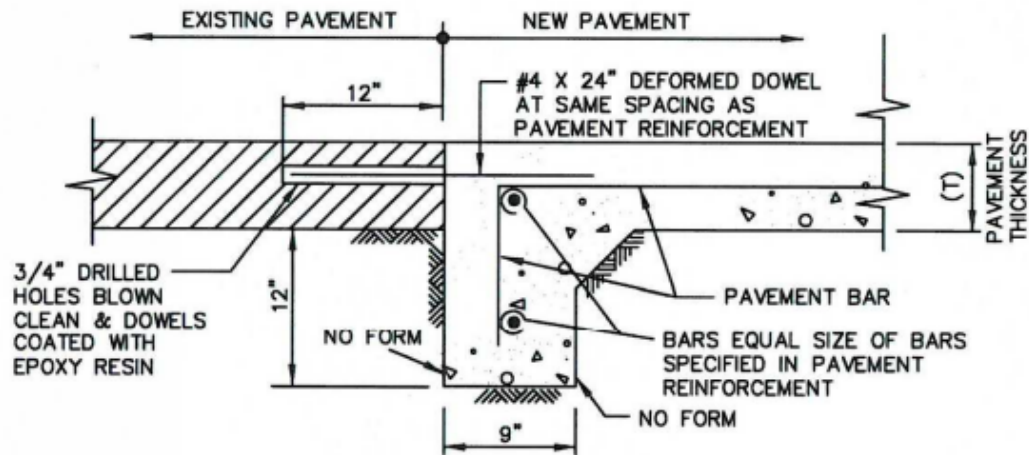
LONGITUDINAL BUTT JOINT  
NOT TO SCALE

REINFORCED CONCRETE PAVEMENT	CITY OF ROCKWALL		
LONGITUDINAL BUTT JOINT		DATE DEC '22	DRAWING NO. R-2051



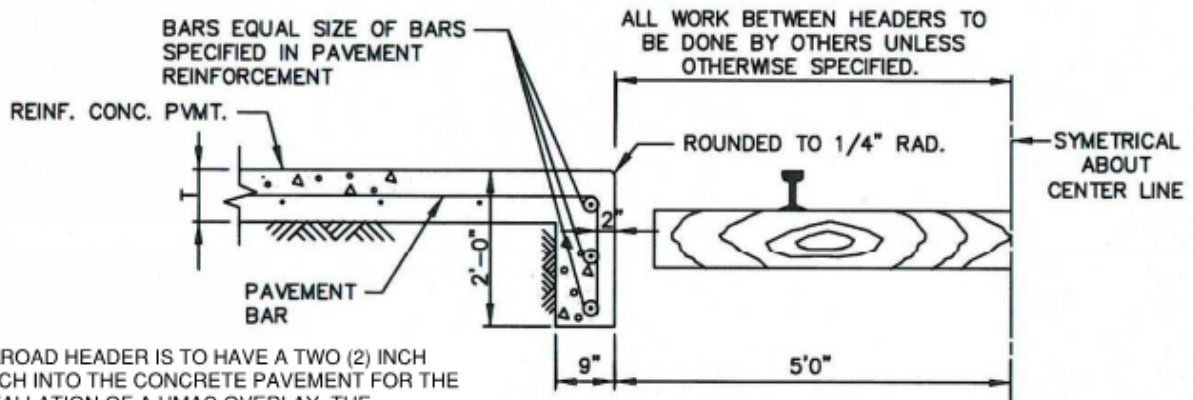
**STREET HEADER FOR FUTURE PAVEMENT**

N.T.S.



**STREET HEADER AT EXISTING PAVEMENT**

N.T.S.



**STREET HEADER AT RAILROAD**

N.T.S.

RAILROAD HEADER IS TO HAVE A TWO (2) INCH NOTCH INTO THE CONCRETE PAVEMENT FOR THE INSTALLATION OF A HMA OVERLAY. THE CONCRETE UNDER THE HMA IS TO BE THE FULL STREET THICKNESS. THE NOTCH SHOULD START AT THE END OF THE PAVEMENT AND GO TWENTY (20) FEET UP THE ROAD AWAY FROM THE CROSSING.

**REINFORCED CONCRETE PAVEMENT**  
**STREET HEADERS**

CITY OF ROCKWALL



STANDARD SPECIFICATION REFERENCE

305.4

DATE

Mar. 2018

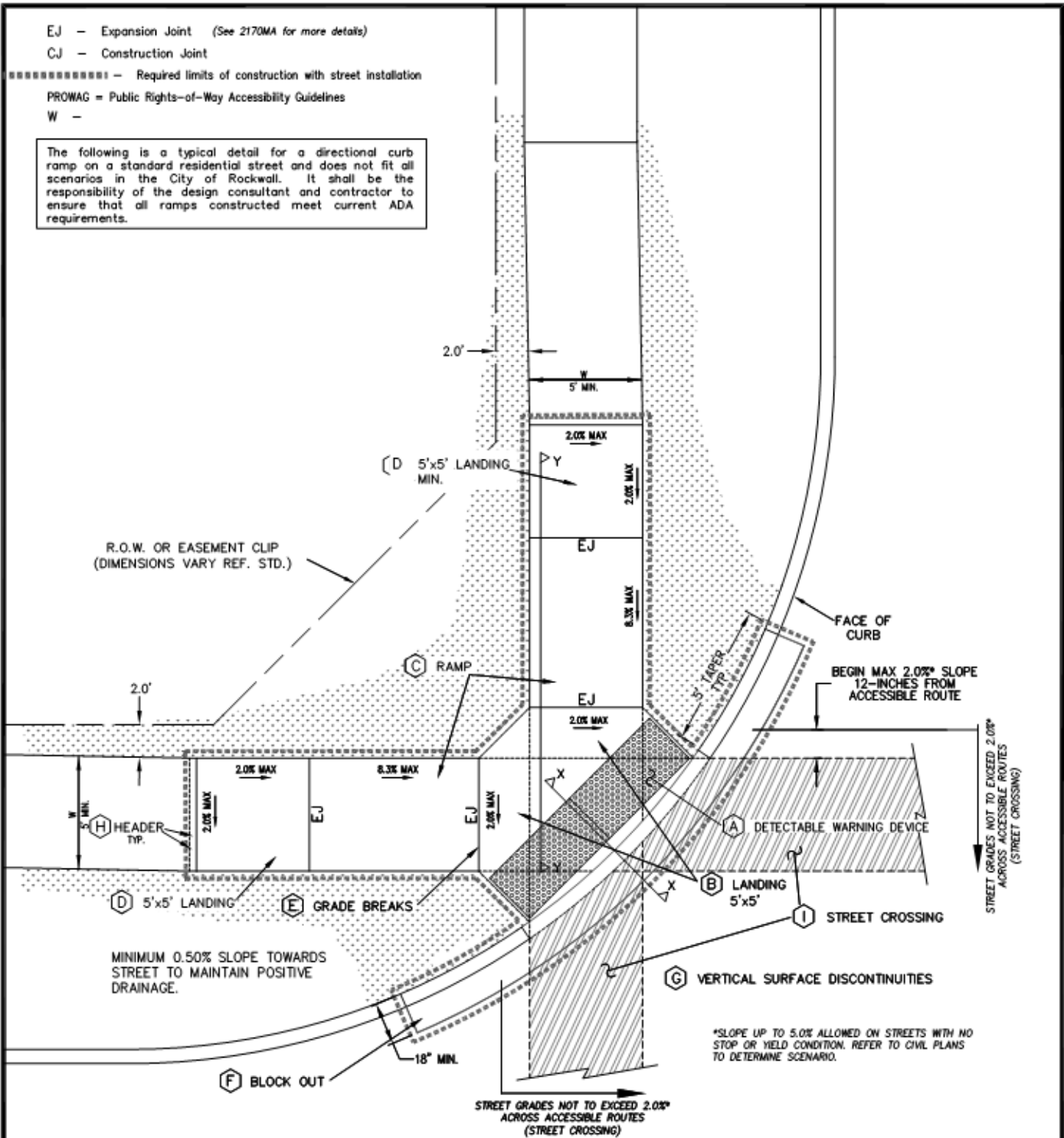
STANDARD DRAWING NO.

R-2070




EJ - Expansion Joint (See 2170MA for more details)  
 CJ - Construction Joint  
 ===== - Required limits of construction with street installation  
 PROWAG = Public Rights-of-Way Accessibility Guidelines  
 W -

The following is a typical detail for a directional curb ramp on a standard residential street and does not fit all scenarios in the City of Rockwall. It shall be the responsibility of the design consultant and contractor to ensure that all ramps constructed meet current ADA requirements.



NOTES: All newly constructed sidewalks, curb ramps and crosswalks installed within City of Rockwall public rights-of-way shall be considered a pedestrian access route and shall conform to the most current "Draft" Guidelines for Public Rights-of-Way created by the United States Access Board.

1. SEE DETAIL R-2125B FOR RAMP FEATURE DESCRIPTIONS
2. SEE DETAIL R-2125C FOR SECTIONS X-X AND Y-Y
3. SEE DETAIL R-2125D FOR ADDITIONAL NOTES

<b>DIRECTIONAL CURB RAMP</b>	<b>CITY OF ROCKWALL</b>	DATE	DRAWING NO.
		MAR. '17	R-2125A



A

Detectable Warning Devices (DWD) shall be pre-manufactured cast-in-place truncated dome plates installed to the manufacturer's specifications, and shall meet all ADA requirements. No Brick Pavers allowed. Color to be approved by the City. DWD shall be 24 inches in length for the full width of the street connection starting at the back of curb. A maximum 2-inch border shall be allowed on the sides of the DWD for proper installation.

B

Also known as "Clear Space" per ADA PROWAG, the City requires a minimum landing space of 5-foot by 5-foot at the bottom of every ramp. This landing space shall have a cross slope in both directions that does not exceed 2.0% and shall be wholly outside the parallel vehicular travel path.

C

The ramp component of the directional curb ramp shall have a continuous longitudinal slope more than 5% and less than 8.3%. The ramp shall also have a cross slope of no more than 2.0%. Length of ramp can vary, but shall not exceed 15 feet to achieve desired elevation change.

D

Also known as "Turning Space" per ADA PROWAG, a minimum landing space of 5-foot by 5-foot shall be at the top of every ramp. This landing (turning) space shall have a cross slope in both directions that does not exceed 2.0%. Landing must match width of sidewalk and length shall be the same distance ("Squared" Landing).

E

All curb ramps shall have grade breaks at the top and bottom that are perpendicular to the direction of the ramp run. Where the ends of the bottom grade break are less than or equal to 5 feet, the DWD shall be placed within the ramp at the bottom grade break. Where either end of the bottom grade break is greater than 5 feet, the DWD shall be placed behind the back of the curb.

F

Paving contractor shall leave block out with a keyway joint installed, minimum of 18 inches measured from back of curb. Block out shall be poured monolithically with Curb Ramp. Concrete shall tie to street paving with a keyway joint per NCTCOG detail 2050. No curb shall be constructed where a DWD is provided. The curb on either side shall have a typical 5 foot taper to transition from the standard 6-inch curb height to be flush with ramp.

G

All work associated with accessible routes shall be installed flush with all features to minimize vertical surface discontinuities. Each segment along accessible route shall be flush with no more (zero tolerance) than a ¼-inch grade separation (elevation difference), or ½-inch grade separation if beveled (bevel slope shall not be steeper than 50%).

H

A sidewalk header shall be constructed at ends of all work performed.


I

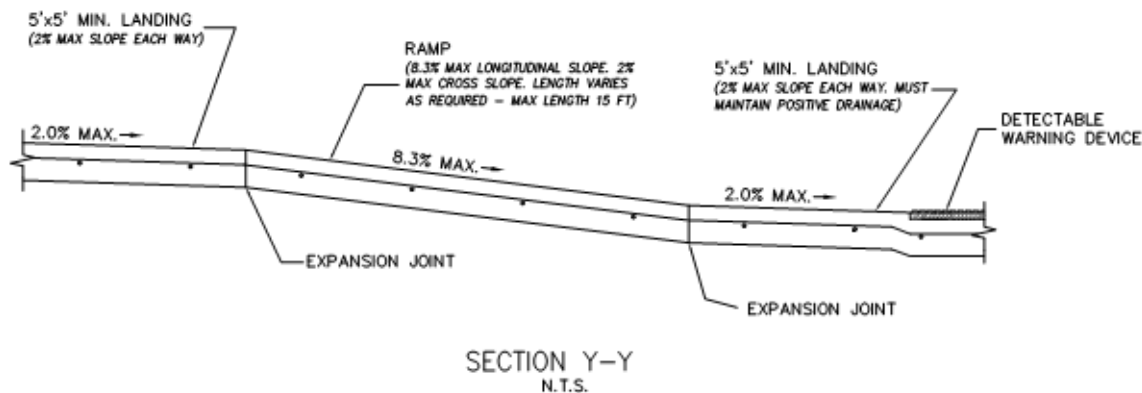
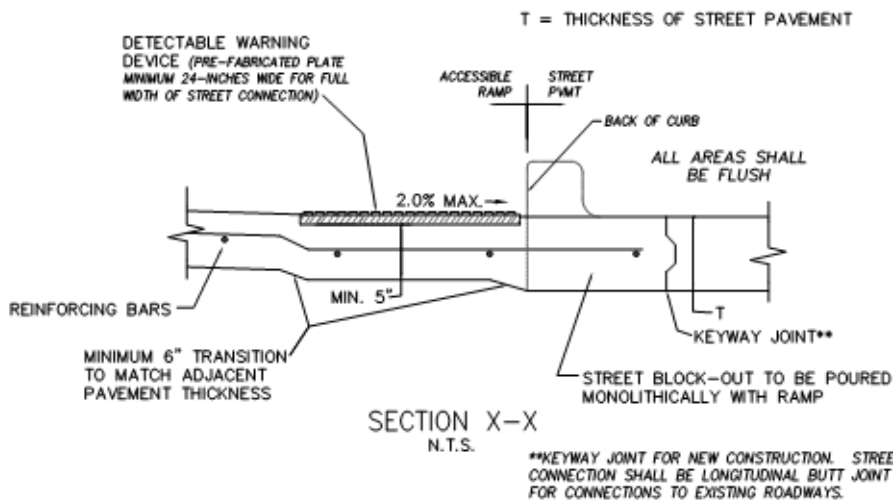
Street crossings shall adhere to same guidelines as other accessible routes within public right-of-way, and shall be for the full width of the in-line accessible route. Cross slope shall not exceed 2%\*. New street construction shall incorporate all ADA design requirements. It shall be the responsibility of the Design Professional and Contractor to ensure all street crossings meet the requirements of PROWAG. Street alterations on existing streets to bring to compliance shall be at the City Engineer's discretion.

J

All curbs constructed as part of an ADA Ramp shall match City curb standards.

\* See PROWAG special design considerations when street crossing has no stop or yield condition.

<b>DIRECTIONAL CURB RAMP</b>		<b>CITY OF ROCKWALL</b>	
			
		DATE	DRAWING NO.
		<b>MAR. '17</b>	<b>R-2125B</b>



NOTE: ALL SIDEWALK CURB RAMPS WILL BE 3,600 PSI (6.5 SACK/CY) CONCRETE.

DIRECTIONAL CURB RAMP

CITY OF ROCKWALL



DATE	DRAWING NO.
MAR. '17	R-2125C



**PEDESTRIAN ACCESSIBILITY (WITHIN PUBLIC R.O.W.)**

All newly constructed sidewalks, curb ramps and crosswalks installed within City of Rockwall public rights-of-way shall be considered a pedestrian access route and shall conform to the most current Guidelines for Public Rights-of-Way created by the United States Access Board.

**CURB RAMPS**


1. All slopes shown are **MAXIMUM ALLOWABLE**. Lesser slopes that will still drain properly should be used. Adjust curb ramp length or grade of approach sidewalks as directed.
2. Landings shall be 5'x 5' minimum with a maximum 2% slope in the transverse and longitudinal directions..
3. Clear space at the bottom of curb ramps shall be a minimum of 5'x 5' wholly contained within the crosswalk and wholly outside the parallel vehicular travel path.
4. Maximum allowable cross slope on sidewalk and curb ramp surfaces is 2%.
5. Additional information on curb ramp location, design, light reflective value and texture may be found in the most current edition of the Texas Accessibility Standards (TAS) and 16 TAC 68.102. Federal guidelines shall supersede any conflicts.
6. Crosswalk dimensions, crosswalk markings and stop bar locations shall be as shown elsewhere in the plans. At intersections where crosswalk markings are not required, curb ramps and accessible routes shall align with theoretical crosswalks unless otherwise directed.
7. Handrails are not required on curb ramps.
8. Provide a flush transition where the curb ramps connect to the street.
9. Accessible routes are considered "ramps" when longitudinal slopes are between 5% and 8.3% (maximum allowable). Sidewalks under 5% longitudinal slope are deemed accessible routes and must follow all applicable guidelines.

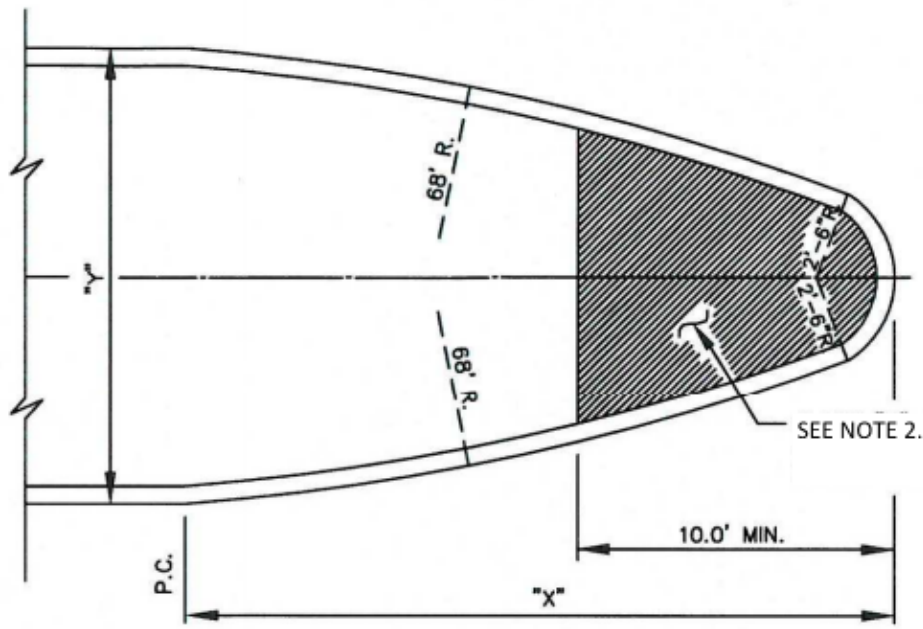
**DETECTABLE WARNING DEVICE**

10. Curb ramps must contain a detectable warning surface that consists of raised truncated domes complying with Section 705 of the TAS. The surface must contrast visually with adjoining surfaces. Furnish and install an approved cast-in-place dark red detectable warning surface material adjacent to uncolored concrete, unless specified elsewhere in the plans.
11. Detectable Warning Materials shall be truncated dome plates in the color approved by the City. Install products in accordance with manufacturer's specifications.
12. Detectable warning surfaces must be slip resistant and not allow water to accumulate.
13. Detectable warning surfaces shall be a minimum of 24" in depth in the direction of pedestrian travel, and extend the full width of the curb ramp or landing where the pedestrian access route enters the street.
14. Detectable warning surfaces shall be located so that the edge nearest the curb line is at the back of curb. When placed on the ramp, align the rows of domes to be perpendicular to the grade break between the ramp run and the street. Where detectable warning surfaces are provided on a surface with a slope that is less than 5 percent, dome orientation is less critical. Detectable warning surfaces may be curved along the corner radius.

**SIDEWALKS**

15. Provide clear ground space at operable parts, including pedestrian push buttons. Operable parts shall be placed within one or more reach ranges specified in TAS 308.
16. Place traffic signal or illumination poles, ground boxes, controller boxes, signs, drainage facilities and other items so as not to obstruct the pedestrian access route or clear ground space.
17. Street grades and cross slopes shall be as shown elsewhere in the plans.
18. Changes in level greater than 1/4 inch are not permitted (1/2 inch with bevel).
19. The least possible grade should be used to maximize accessibility. The running slope of sidewalks and crosswalks within the public right of way may follow the grade of the parallel roadway. Where a continuous grade greater than 5% must be provided, handrails may be desirable to improve accessibility. Handrails may also be needed to protect pedestrians from potentially hazardous conditions. If provided, handrails shall comply with TAS 505.
20. Handrail extensions shall not protrude into the usable landing area or into intersecting pedestrian routes.

<b>DIRECTIONAL CURB RAMP</b>	<b>CITY OF ROCKWALL</b> 	DATE	DRAWING NO.
		<b>MAR. '17</b>	<b>R-2125D</b>



DIMENSIONS OF MEDIAN NOSE

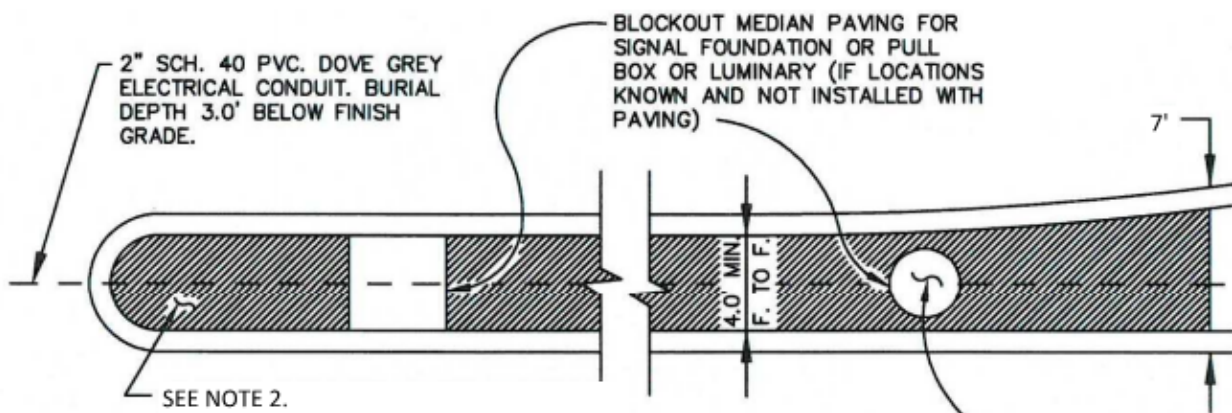
Y = 15'	X = 27.6'
Y = 16'	X = 28.8'
Y = 17'	X = 29.9'
Y = 18'	X = 30.9'

CONCRETE NOSE FOR MEDIAN ISLAND

N.T.S.

NOTES

1. LEFT TURN LANE SHALL HAVE A MOWER ACCESS RAMP.
2. MEDIAN PAVING TO BE CONSTRUCTED OF INTEGRAL STAMPED & STAINED REINFORCED CONCRETE, COLOR AND PATTERN TO BE APPROVED BY THE CITY. CONCRETE TO BE MINIMUM SIX (6") INCH 3600PSI (6.5 SACK/CY) WITH #4 BARS ON 18" CENTERS.
3. STREET LIGHT POLE BASES IN MEDIAN ARE TO HAVE THIRTY-SIX (36") INCH BY THIRTY-SIX (36") INCH, FOUR (4") INCH THICK, 3000PSI REINFORCED CONCRETE MOW STRIP.



LEFT TURN LANE MEDIAN PAVEMENT

N.T.S.

MEDIAN ISLAND PAVEMENT  
NOSE & LEFT TURN LANE

CITY OF ROCKWALL

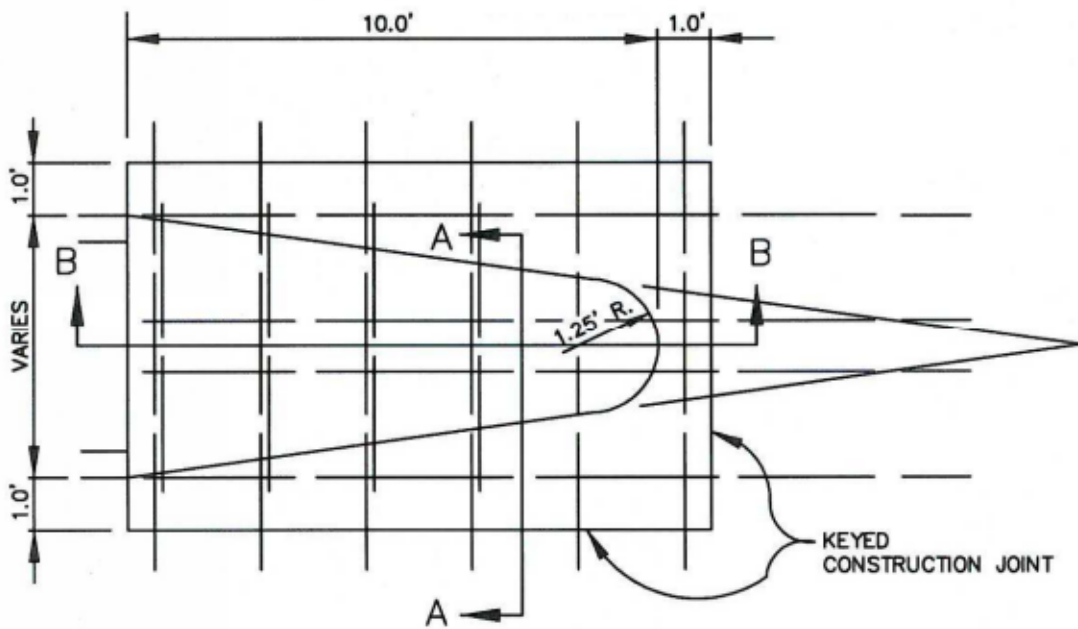


STANDARD SPECIFICATION REFERENCE  
305.3

DATE  
AUG. '19

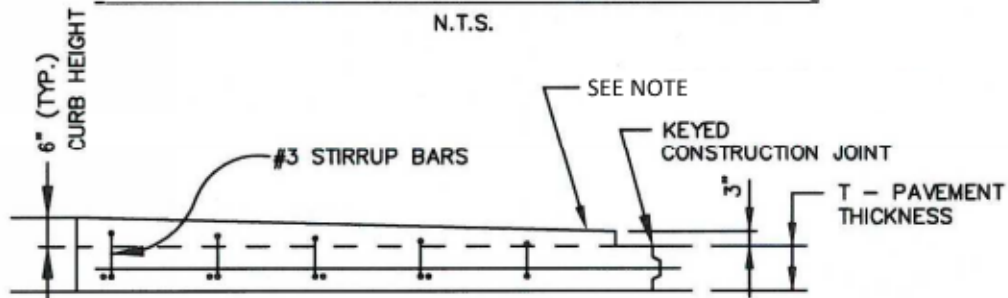
STANDARD DRAWING NO.  
R-2130





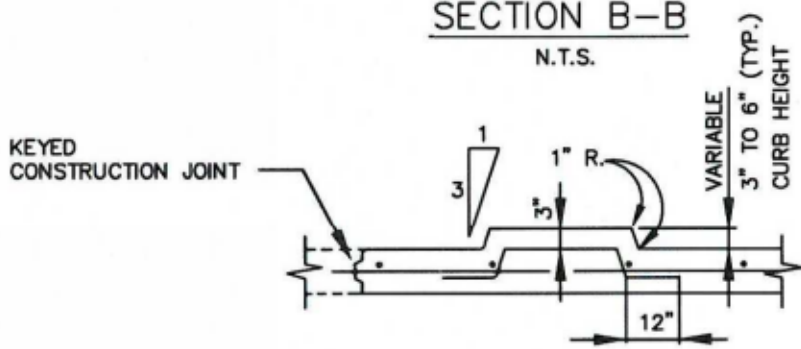
**MONOLITHIC CONCRETE MEDIAN NOSE**

N.T.S.



**SECTION B-B**

N.T.S.



**SECTION A-A**

N.T.S.

- NOTE:
1. MEDIAN NOSE PAVEMENT STRENGTH SHALL MATCH THAT OF STREET PAVING.
  2. MONOLITHIC NOSE REQUIRED WHEN LESS THAN 6.0' FACE TO FACE.
  3. REINFORCEMENT BARS SHALL MATCH THOSE IN PAVEMENT.

MEDIAN ISLAND PAVEMENT  
MONOLITHIC CONCRETE NOSE

CITY OF ROCKWALL



STANDARD SPECIFICATION REFERENCE

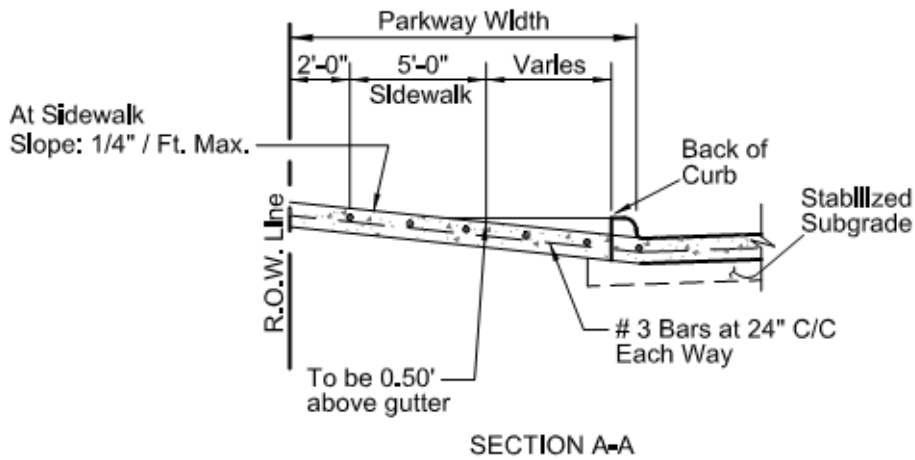
305.3

DATE

AUG. '19

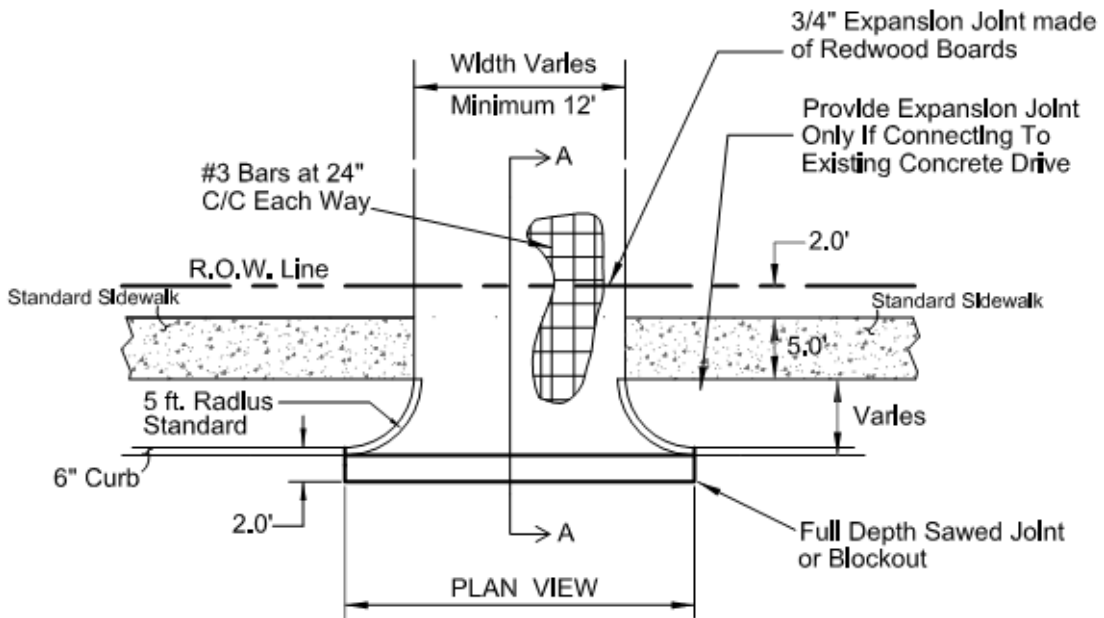
STANDARD DRAWING NO.

R-2140




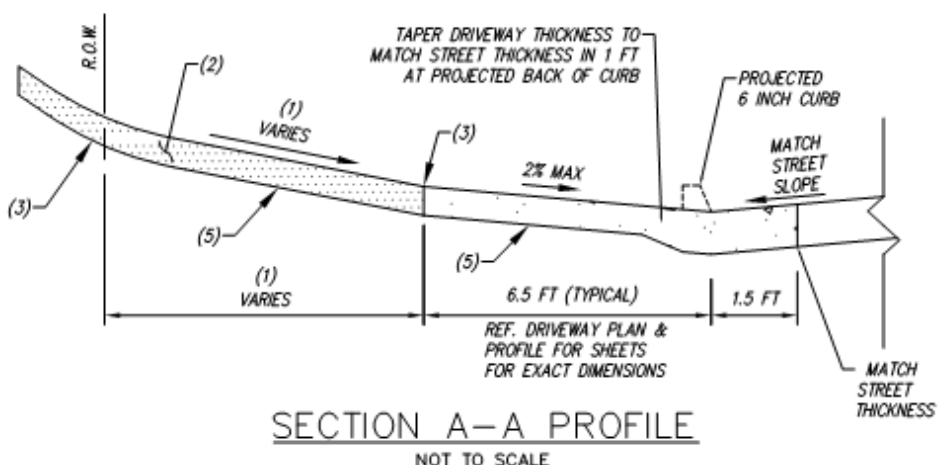
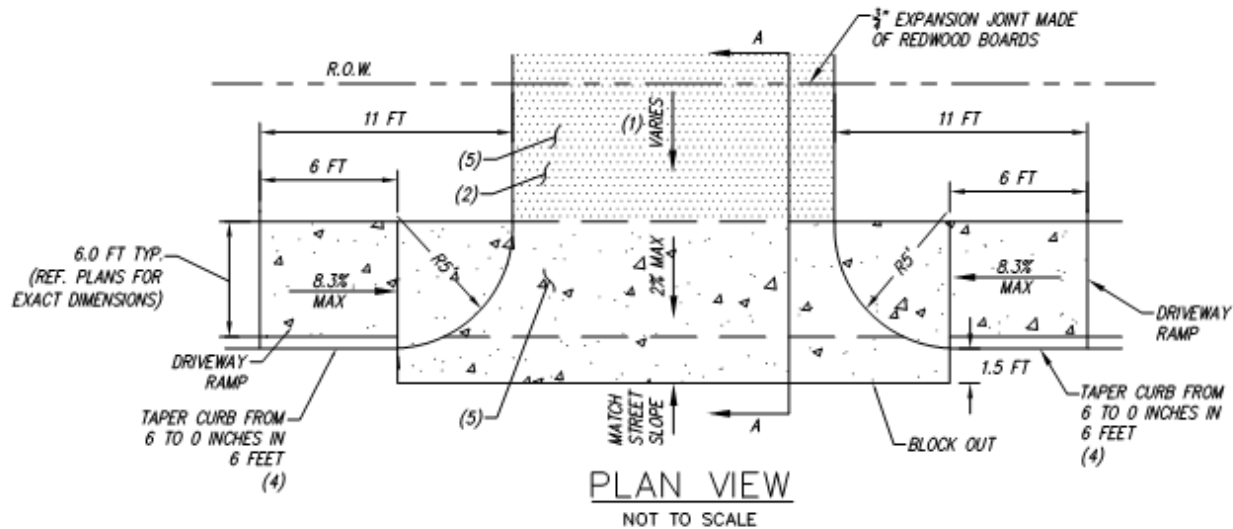
**NOTE:**

Sidewalk section thru driveway to be poured same thickness as driveway - 6" Thick 3,600 P.S.I. Reinf. Conc. Pvmt. w/ #3 Bars @ 24" O.C.E.W. (Grade 60 Steel)



**DRIVEWAY DETAILS**  
(Not to Scale)

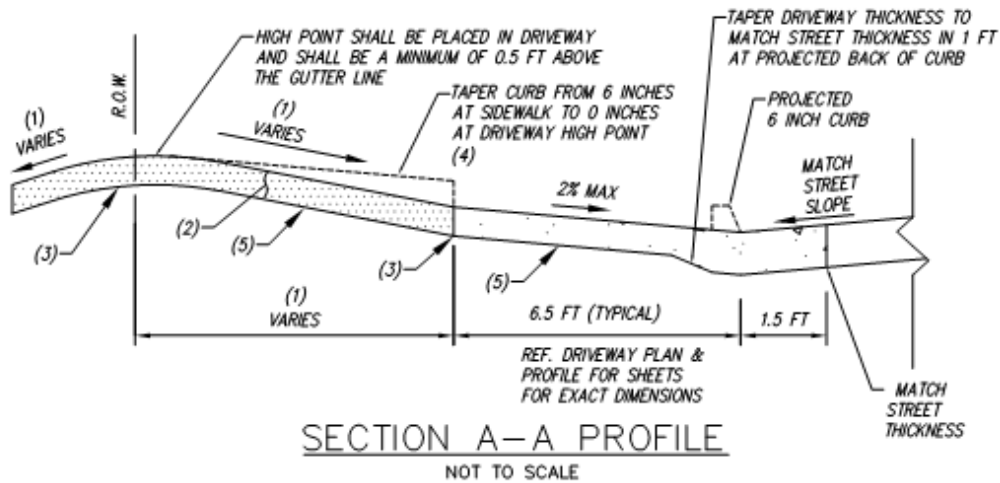
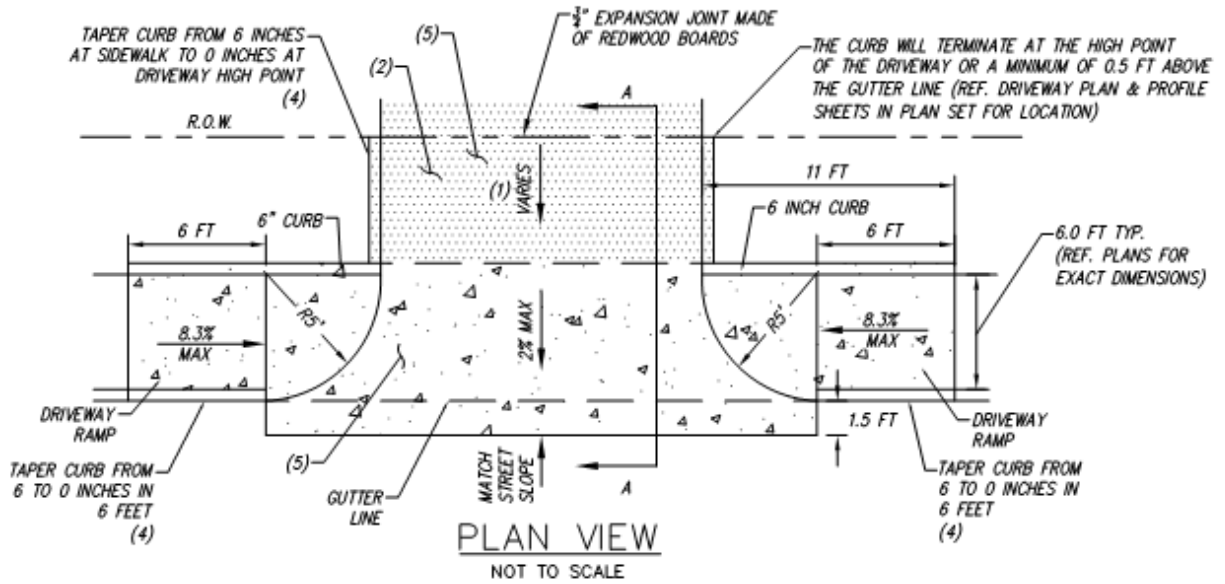
DRIVEWAY DETAIL	CITY OF ROCKWALL		
RESIDENTIAL DRIVEWAY		DATE AUG '19	DRAWING NO. R-2150



- (1) REFERENCE DRIVEWAY PLAN AND PROFILE SHEETS FOR EXACT GRADES AND VERTICAL CURVE INFORMATION
- (2) FOR ROAD RECONSTRUCTION PROJECTS THE DRIVEWAY MATERIAL/FINISH TYPE BEHIND THE SIDEWALK SHALL MATCH THE EXISTING DRIVEWAY MATERIAL TYPE/FINISH (EXPOSED AGGREGATE, STAMPED STAINED, PAVERS, ETC.) THE SIDEWALK CROSSING SHALL BE STANDARD BROOM FINISH.
- (3) VERTICAL CURVES SHALL BE INSTALLED PER THE DRIVEWAY PROFILE FOUND IN THE PLAN SET. WHEN DRIVEWAY PROFILES ARE NOT PROVIDED VERTICAL CURVES SHALL BE INSTALLED WHEN AN ALGEBRAIC CHANGE IN GRADE OCCURS WITHIN A DRIVEWAY OF MORE THAN 4%. THE MINIMUM RECOMMENDED LENGTHS OF VERTICAL CURVE FOR THE CORRESPONDING CHANGE IN GRADE FOR DRIVEWAY PROFILES ARE SHOWN IN THE TABLE. IT IS RECOMMENDED TO PUT A 2 FOOT VERTICAL CURVE WHERE EVER THE ALGEBRAIC CHANGE IN GRADE IS LESS THAN 4%.
- (4) SAWCUTTING OF CURB FOR CURB HEIGHT TAPER WILL NOT BE ALLOWED. FULL DRIVEWAY AND SIDEWALK PANEL REPLACEMENT WILL BE REQUIRED IF SAWCUTTING OCCURS.
- (5) REINFORCED CONCRETE SHALL BE MIN. 6" THICK, 3,600 PSI (6.5 SACK/CY) W/ #3 BARS @ 24" O.C.E.W.

VERTICAL CURVE LENGTHS FOR DRIVEWAYS		
ALGEBRAIC CHANGE IN GRADE	MINIMUM LENGTH (FT)	
	CREST CURVE	SAG CURVE
< 4%	2	2
4% - 5%	5	6
6% - 8%	5	7
9% - 12%	6	8

RESIDENTIAL DRIVEWAY - SIDEWALK ADJACENT TO CURB	CITY OF ROCKWALL 			
HIGH SIDE OF STREET		<table border="1" style="width: 100%; border-collapse: collapse;"> <tr> <td style="width: 50%; padding: 2px;">DATE MAY '21</td> <td style="width: 50%; padding: 2px;">DRAWING NO. R-2151A</td> </tr> </table>	DATE MAY '21	DRAWING NO. R-2151A
DATE MAY '21	DRAWING NO. R-2151A			

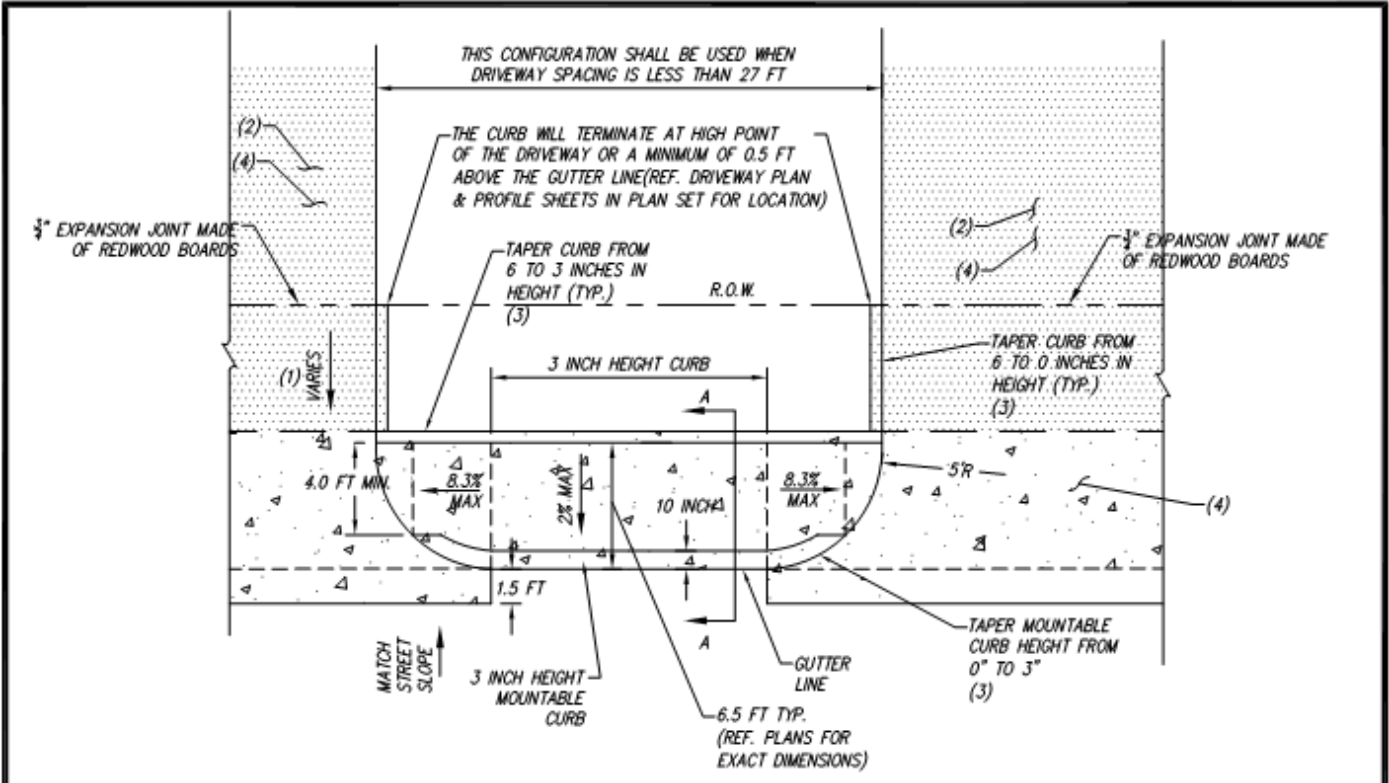


- (1) REFERENCE DRIVEWAY PLAN AND PROFILE SHEETS FOR EXACT GRADES AND VERTICAL CURVE INFORMATION
- (2) FOR ROAD RECONSTRUCTION PROJECTS THE DRIVEWAY MATERIAL/FINISH TYPE BEHIND THE SIDEWALK SHALL MATCH THE EXISTING DRIVEWAY MATERIAL TYPE/FINISH (EXPOSED AGGREGATE, STAMPED STAINED, PAVERS, ETC.) THE SIDEWALK CROSSING SHALL BE STANDARD BROOM FINISH.
- (3) VERTICAL CURVES SHALL BE INSTALLED PER THE DRIVEWAY PROFILE FOUND IN THE PLAN SET. WHEN DRIVEWAY PROFILES ARE NOT PROVIDED VERTICAL CURVES SHALL BE INSTALLED WHEN AN ALGEBRAIC CHANGE IN GRADE OCCURS WITHIN A DRIVEWAY OF MORE THAN 4%. THE MINIMUM RECOMMENDED LENGTHS OF VERTICAL CURVE FOR THE CORRESPONDING CHANGE IN GRADE FOR DRIVEWAY PROFILES ARE SHOWN IN THE TABLE. IT IS RECOMMENDED TO PUT A 2 FOOT VERTICAL CURVE WHERE EVER THE ALGEBRAIC CHANGE IN GRADE IS LESS THAN 4%.
- (4) SAWCUTTING OF CURB FOR CURB HEIGHT TAPER WILL NOT BE ALLOWED. FULL DRIVEWAY AND SIDEWALK PANEL REPLACEMENT WILL BE REQUIRED IF SAWCUTTING OCCURS.
- (5) REINFORCED CONCRETE SHALL BE MIN. 6" THICK, 3,600 PSI (6.5 SACK/CY) W/ #3 BARS @ 24" O.C.E.W

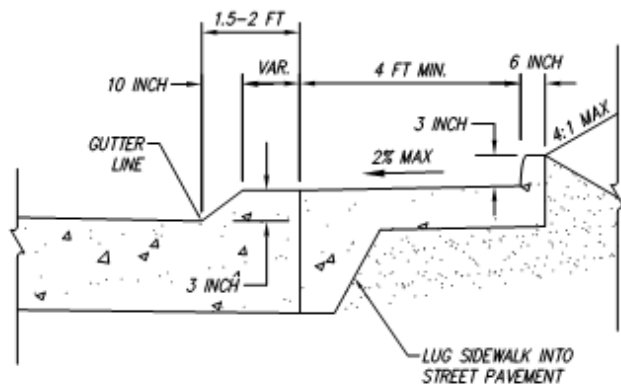
VERTICAL CURVE LENGTHS FOR DRIVEWAYS		
ALGEBRAIC CHANGE IN GRADE	MINIMUM LENGTH (FT)	
	CREST CURVE	SAG CURVE
< 4%	2	2
4% - 5%	5	6
6% - 8%	5	7
9% - 12%	6	8

NOTE: NO DOWNGRADE DRIVEWAYS WILL BE ALLOWED FOR NEW DEVELOPMENT OR NEW CONSTRUCTION.

RESIDENTIAL DRIVEWAY - SIDEWALK ADJACENT TO CURB	CITY OF ROCKWALL 	
LOW SIDE OF STREET		DATE MAY '21
		DRAWING NO. R-2151B




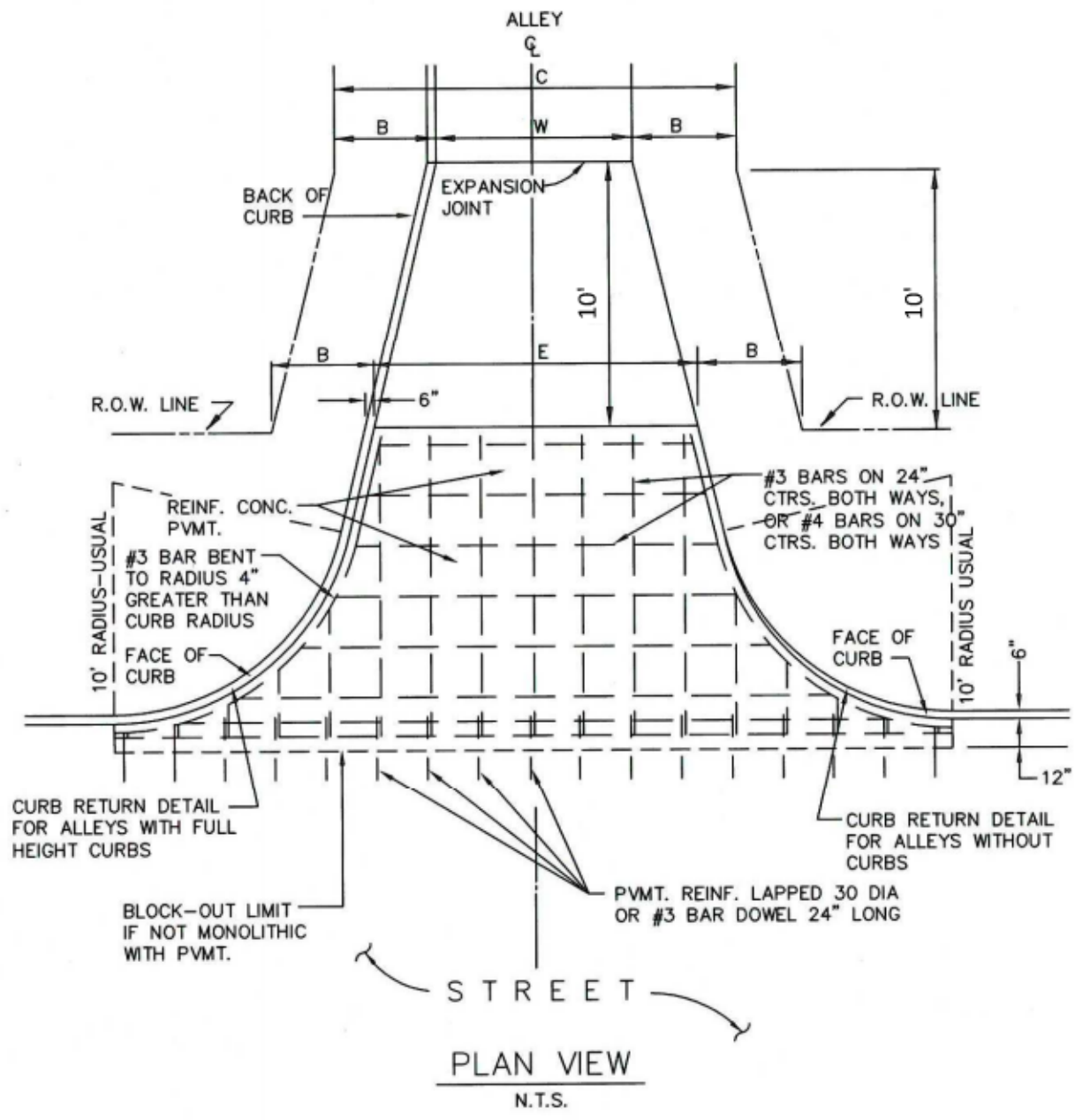
**PLAN VIEW**  
NOT TO SCALE



**SECTION A-A**  
NOT TO SCALE

- (1) REFERENCE DRIVEWAY PLAN AND PROFILE SHEETS FOR EXACT GRADES AND VERTICAL CURVE INFORMATION
- (2) FOR ROAD RECONSTRUCTION PROJECTS THE DRIVEWAY MATERIAL/FINISH TYPE BEHIND THE SIDEWALK SHALL MATCH THE EXISTING DRIVEWAY MATERIAL TYPE/FINISH (EXPOSED AGGREGATE, STAMPED STAINED, PAVERS, ETC.) THE SIDEWALK CROSSING SHALL BE STANDARD BROOM FINISH.
- (3) SAWCUTTING OF CURB FOR CURB HEIGHT TAPER WILL NOT BE ALLOWED. FULL DRIVEWAY AND SIDEWALK PANEL REPLACEMENT WILL BE REQUIRED IF SAWCUTTING OCCURS.
- (4) DRIVEWAY REINFORCED CONCRETE SHALL BE MIN. 6" THICK, 3,600 PSI (6.5 SACK/CY) W/ #3 BARS @ 24" O.C.E.W

RESIDENTIAL DRIVEWAY - SIDEWALK ADJACENT TO CURB	CITY OF ROCKWALL 	
DRIVEWAYS CLOSER THAN 27-FT		DATE MAY '21 DRAWING NO. R-2152

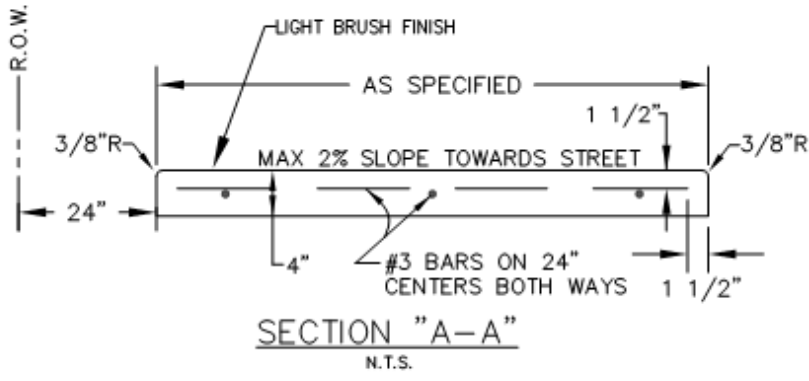
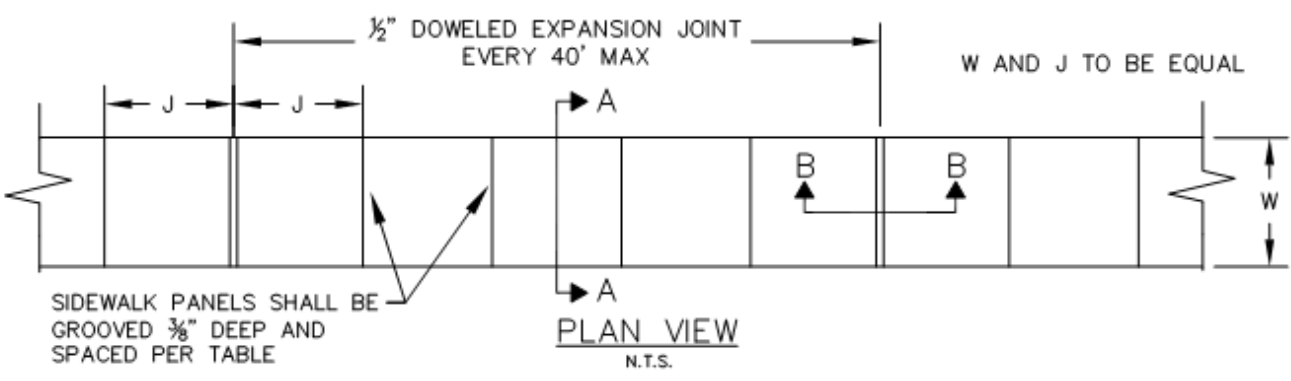


ALLEY WIDTH (W)	R.O.W. WIDTH (C)	B	E
12'	20'	4'	14'

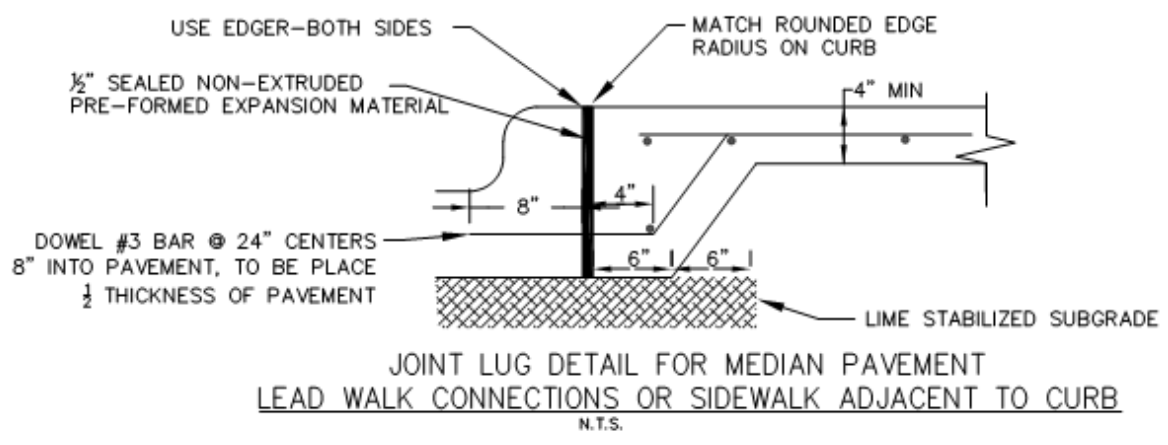
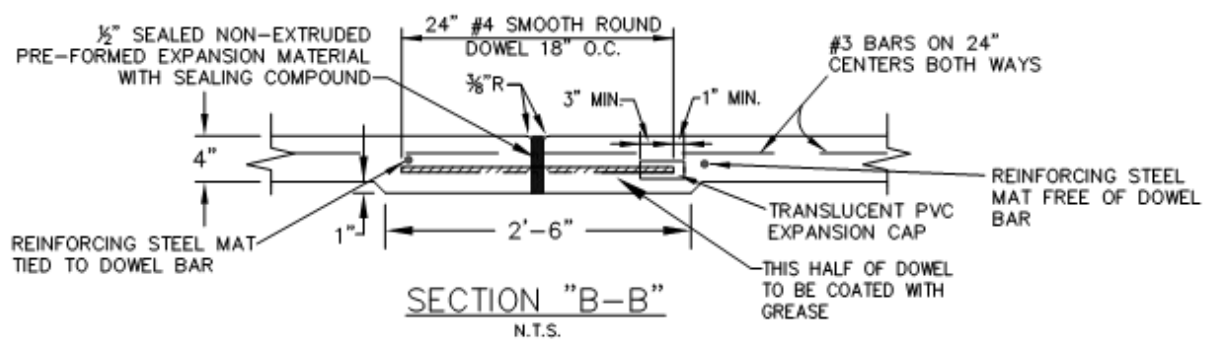
ALLEY APPROACH  
RADIUS RETURN TYPE



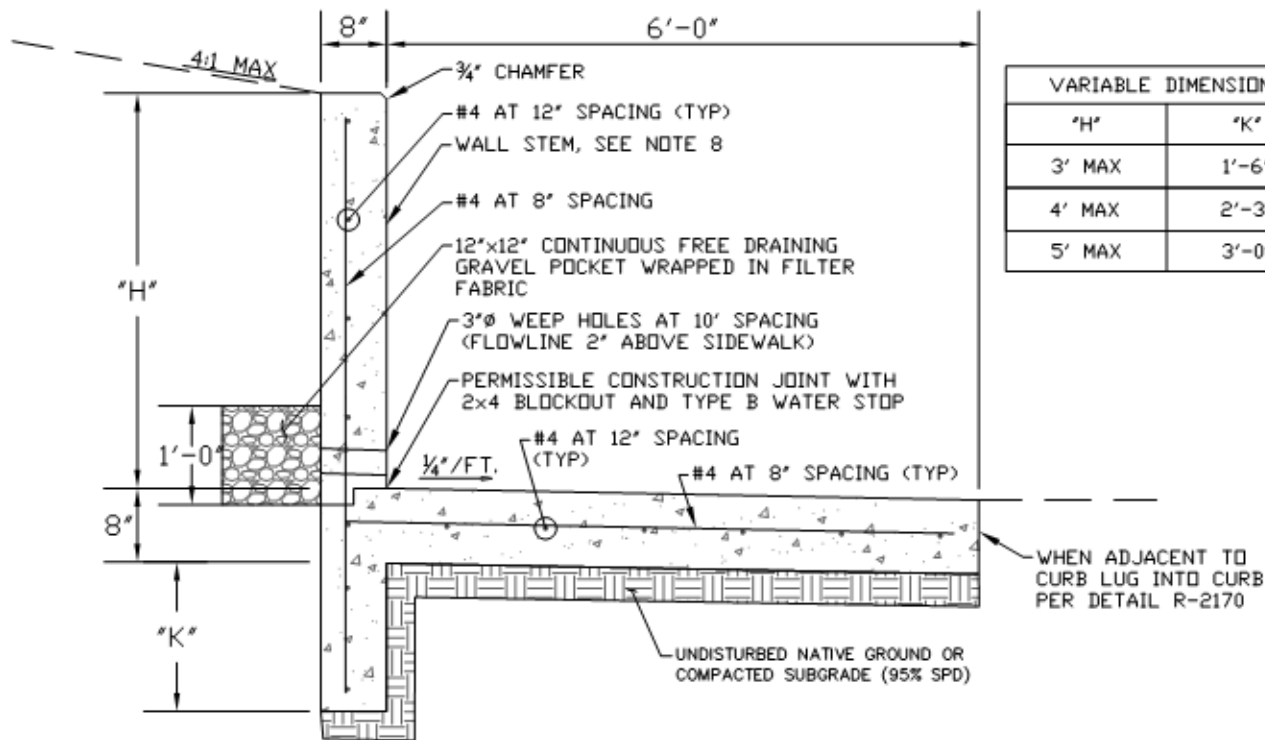
STANDARD SPECIFICATION REFERENCE 305.2	
DATE Mar. 2018	STANDARD DRAWING NO. R-2160



- NOTES:
1. CROSS SLOPE OF SIDEWALK SHALL BE NO GREATER THAN 2%
  2. SIDEWALK CONCRETE WITHIN CITY R.O.W. SHALL BE MINIMUM 3,000 PSI (5.5 SACK/C.Y.) CONCRETE.
  3. ALL SIDEWALKS SHALL MAINTAIN POSITIVE DRAINAGE.
  4. ALL HONEYCOMB IN BACK OD CURB TO BE TROWEL-PLASTERED BEFORE POURING SIDEWALK.
  5. MINIMUM WIDTH OF 6' IF SIDEWALK ADJACENT TO CURB A LUGGED INTO THE CURB.
  6. STEEL WIRE MESH IS NOT ACCEPTABLE.



REINFORCED CONCRETE SIDEWALKS	CITY OF ROCKWALL	
JOINTS AND SPACING	DATE AUG '19	DRAWING NO. R-2170



VARIABLE DIMENSIONS	
"H"	"K"
3' MAX	1'-6"
4' MAX	2'-3"
5' MAX	3'-0"

RETAINING WALL WITH INTEGRAL SIDEWALK

N.T.S.

NOTES:

- FOR USE OF THIS STANDARD DETAIL, THE FOLLOWING GEOTECHNICAL SITE CONDITIONS MUST BE MET:
  - MINIMUM ALLOWABLE BEARING PRESSURE: 1,500 PSF
  - MINIMUM COEFFICIENT OF FRICTION: 0.3
  - MAXIMUM ACTIVE PRESSURE COEFFICIENT (K<sub>a</sub>): 0.65
- ALL MATERIALS SHALL BE SUBMITTED FOR APPROVAL PRIOR TO CONSTRUCTION.
- ALL CONCRETE SHALL HAVE A MINIMUM COMPRESSIVE STRENGTH OF 4000 PSI.
- ALL REINFORCING STEEL SHALL BE GRADE 60.
- ALL CLEAR COVER SHALL BE 2" WHERE FORMED AND 3" WHERE CAST AGAINST EARTH.
- IF ANY SURCHARGE LOAD IS ANTICIPATED AN ENGINEERING DESIGN IS REQUIRED, SEALED BY A REGISTERED ENGINEER IN THE STATE OF TEXAS. THIS INCLUDES DEAD LOAD SURCHARGES AND LIVE LOAD SURCHARGES SUCH AS TRAFFIC LOADS.
- JOINT LOCATIONS SHALL MATCH ON SIDEWALK AND WALL. JOINT SPACING SHALL BE EVERY 30 FEET FOR CONTROL JOINTS AND EVERY 90 FEET FOR EXPANSION JOINTS. TYPE B WATERSTOP SHALL BE APPLIED ON THE FILL SIDE OF ALL EXPANSION AND CONSTRUCTION JOINTS.
- WALL FACE SHALL BE FORM LINER OR STONE VENEER WITH RANDOM ROCK ASHLAR PATTERN, NO SMOOTH CONCRETE SURFACE ALLOWED


REINFORCED CONCRETE RETAINING WALL	CITY OF ROCKWALL		
		DATE	DRAWING NO.
INTEGRAL WITH SIDEWALK		AUG '19	R-2180

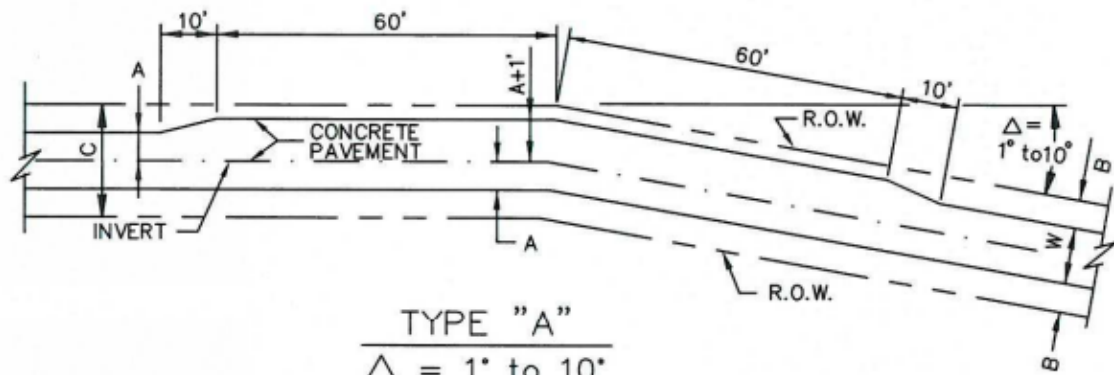




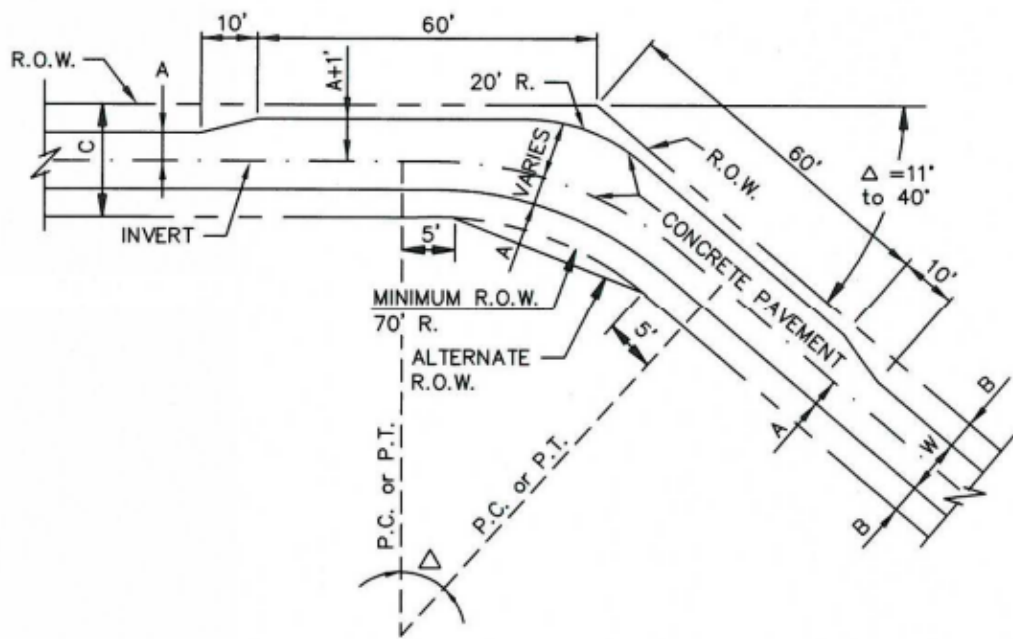
GENERAL NOTES:

- 1. REINFORCED CONCRETE PAVEMENT:
  - A. ALL CURBS SHALL BE PLACED INTEGRAL WITH PAVEMENT UNLESS OTHERWISE APPROVED BY THE OWNER.
  - B. CURBS SHALL MEET THE SAME COMPRESSIVE STRENGTH AS SPECIFIED FOR THE PAVEMENT.
  - C. BAR LAPS SHALL BE 30 DIAMETERS.
  - D. REINFORCING BARS SHALL BE SUPPORTED BY CHAIRS OR OTHER DEVICES APPROVED BY THE OWNER.
  
- 2. SUBGRADE: (UNLESS OTHERWISE SPECIFIED BY OWNER)
  - A. SUBGRADE UNDER ALL PAVEMENTS SHALL BE STABILIZED TO A MINIMUM DEPTH OF SIX (6") INCHES WITH HYDRATED LIME CEMENT. LABORATORY TESTS WILL BE PERFORMED TO DETERMINE THE AMOUNT OF LIME OR CEMENT TO USE.

PAVEMENT SYSTEMS	CITY OF ROCKWALL	STANDARD SPECIFICATION REFERENCE	
GENERAL NOTES		302,303	
		DATE	STANDARD DRAWING NO.
		Mar. 2018	R-2190




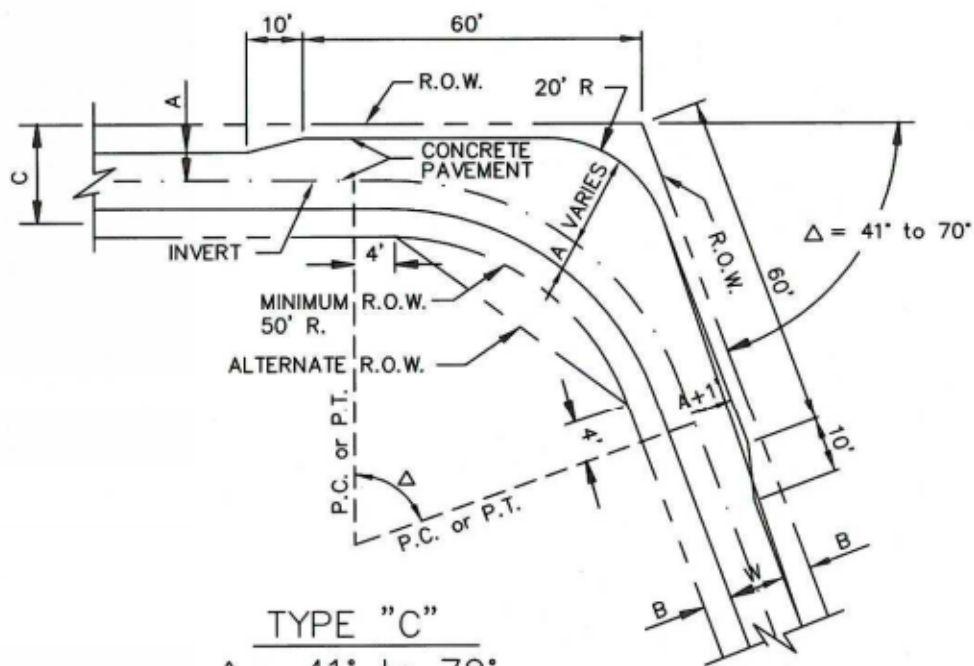
TYPE "A"  
 $\Delta = 1^\circ \text{ to } 10^\circ$   
 N.T.S.



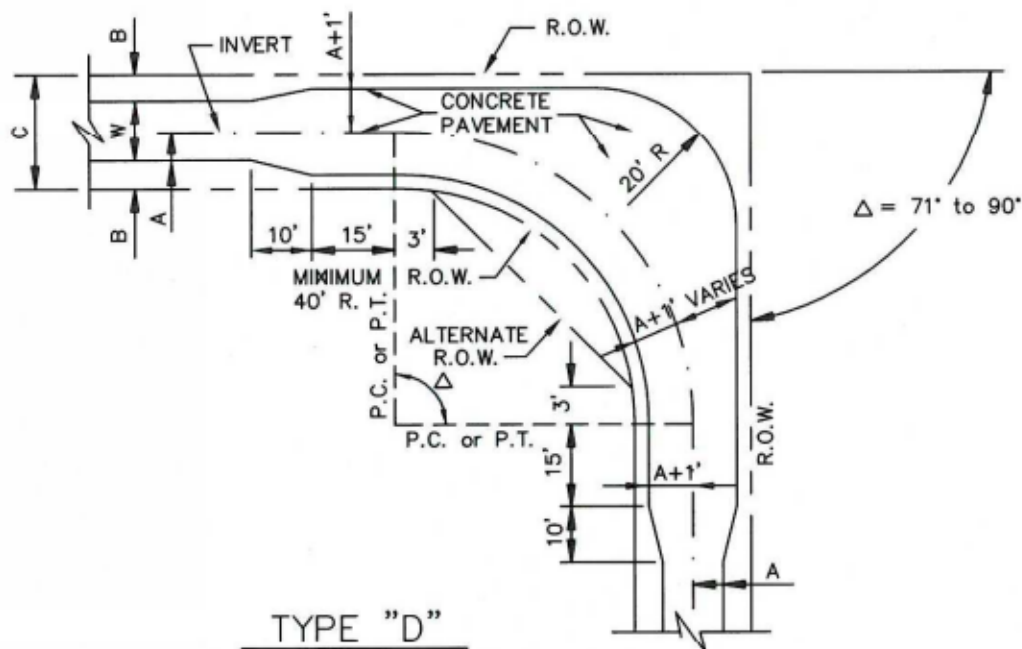
TYPE "B"  
 $\Delta = 11^\circ \text{ to } 40^\circ$   
 N.T.S.

- NOTES:
1. ALLEY WIDTH SHALL BE TWELVE (12') FEET MINIMUM.
  2. ALLEY R.O.W. SHALL BE TWENTY (20') FEET MINIMUM.
  3. DIMENSION A= SIX (6') FEET.
  4. DIMENSION B= FOUR (4') FEET.

ALLEY GEOMETRICS TYPE "A" & TYPE "B"	CITY OF ROCKWALL 	STANDARD SPECIFICATION REFERENCE 303.5
	DATE Mar. 2018	STANDARD DRAWING NO. R-2210



**TYPE "C"**  
 $\Delta = 41^\circ$  to  $70^\circ$   
 N.T.S.



**TYPE "D"**  
 $\Delta = 71^\circ$  to  $90^\circ$   
 N.T.S.

NOTES:

1. ALLEY WIDTH SHALL BE TWELVE (12') FEET MINIMUM.
2. ALLEY R.O.W. SHALL BE TWENTY (20') FEET MINIMUM.
3. DIMENSION A= SIX (6') FEET.
4. DIMENSION B= FOUR (4') FEET.

ALLEY GEOMETRICS  
 TYPE "C" & TYPE "D"

CITY OF ROCKWALL



STANDARD SPECIFICATION REFERENCE

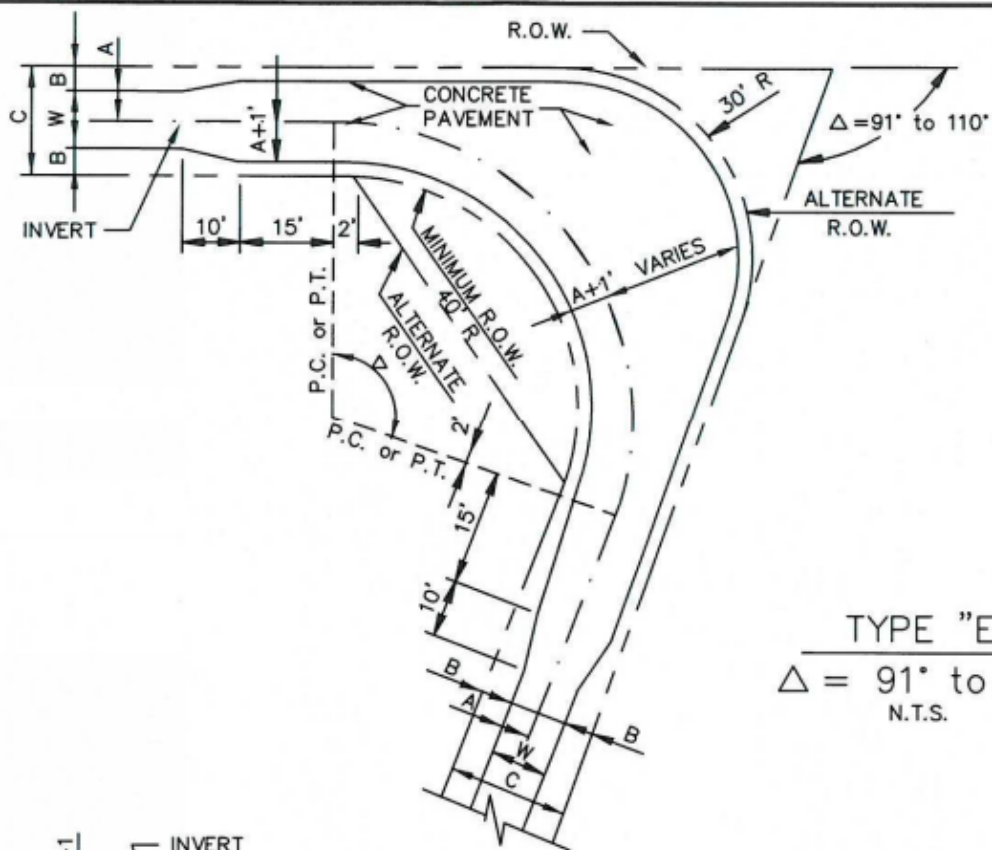
303.5

DATE

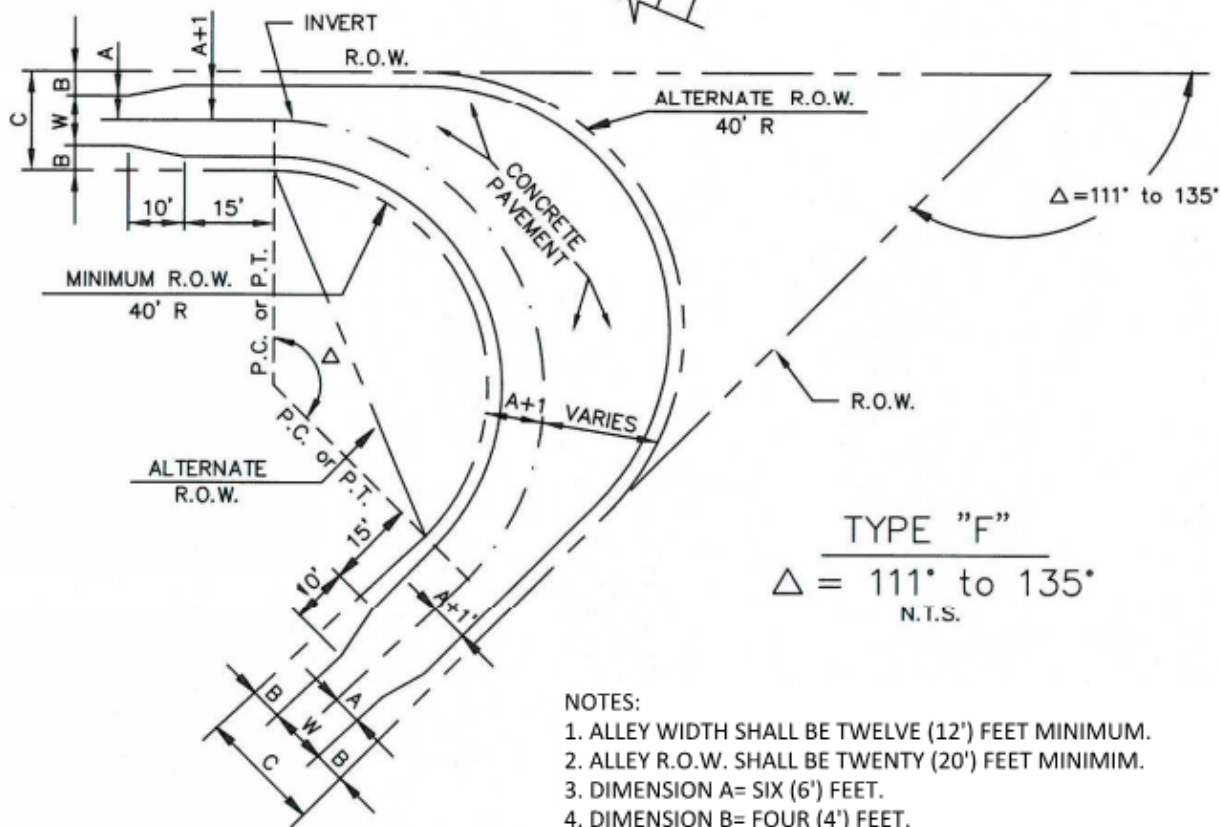
Mar. 2018

STANDARD DRAWING NO.

R-2220



TYPE "E"  
 $\Delta = 91^\circ \text{ to } 110^\circ$   
 N.T.S.



TYPE "F"  
 $\Delta = 111^\circ \text{ to } 135^\circ$   
 N.T.S.

- NOTES:
1. ALLEY WIDTH SHALL BE TWELVE (12') FEET MINIMUM.
  2. ALLEY R.O.W. SHALL BE TWENTY (20') FEET MINIMUM.
  3. DIMENSION A= SIX (6') FEET.
  4. DIMENSION B= FOUR (4') FEET.

ALLEY GEOMETRICS  
 TYPE "E" & TYPE "F"

CITY OF ROCKWALL



STANDARD SPECIFICATION REFERENCE

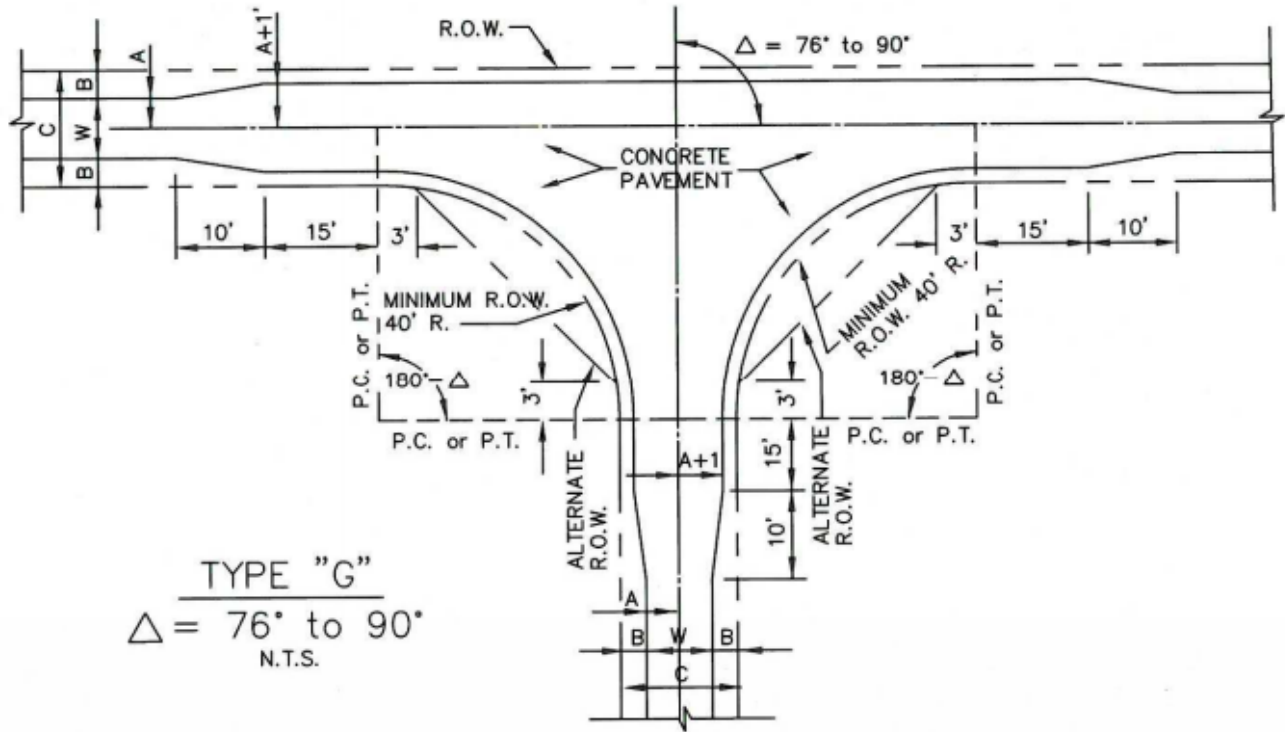
303.5

DATE

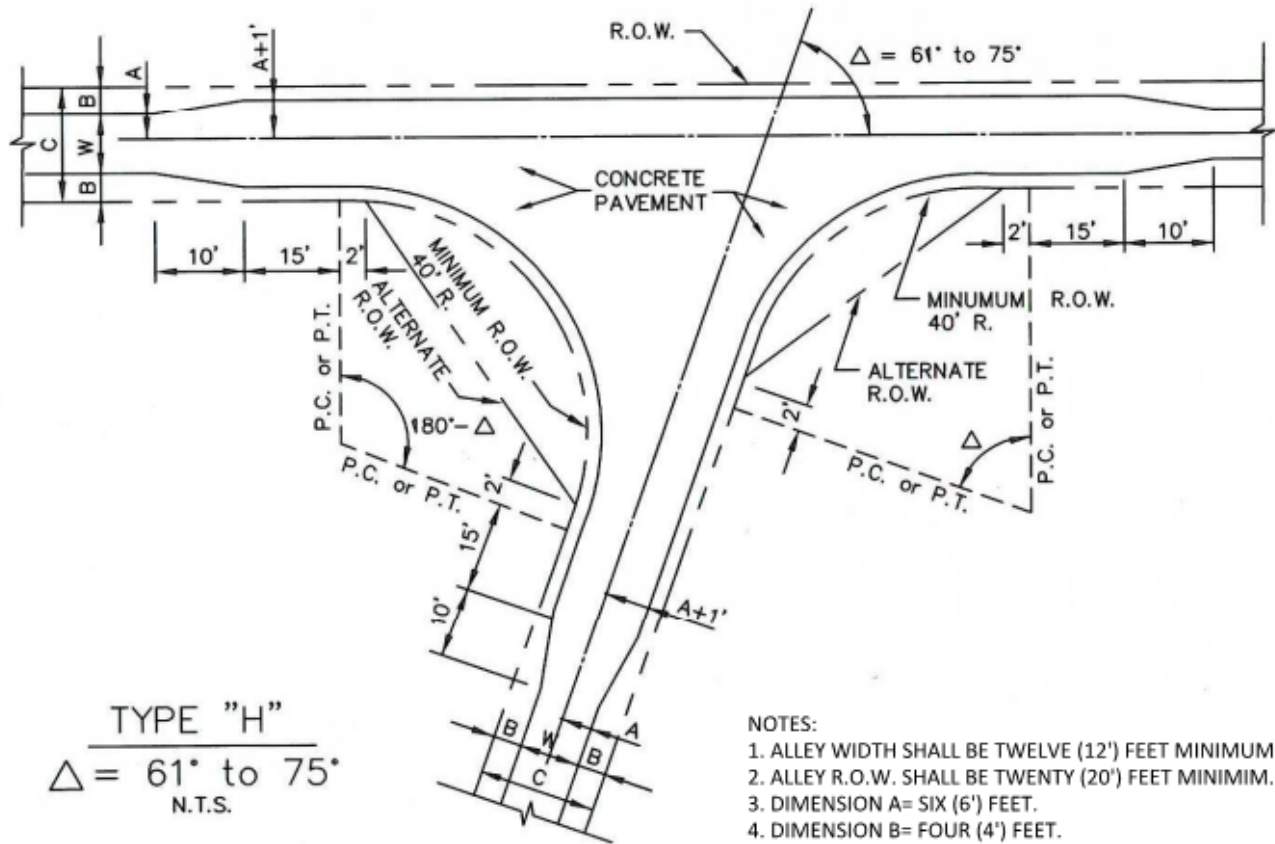
Mar. 2018

STANDARD DRAWING NO.

R-2230



TYPE "G"  
 $\Delta = 76^\circ \text{ to } 90^\circ$   
 N.T.S.



TYPE "H"  
 $\Delta = 61^\circ \text{ to } 75^\circ$   
 N.T.S.

- NOTES:
1. ALLEY WIDTH SHALL BE TWELVE (12') FEET MINIMUM.
  2. ALLEY R.O.W. SHALL BE TWENTY (20') FEET MINIMUM.
  3. DIMENSION A= SIX (6') FEET.
  4. DIMENSION B= FOUR (4') FEET.

ALLEY GEOMETRICS

TYPE "G" & TYPE "H"

CITY OF ROCKWALL



STANDARD SPECIFICATION REFERENCE

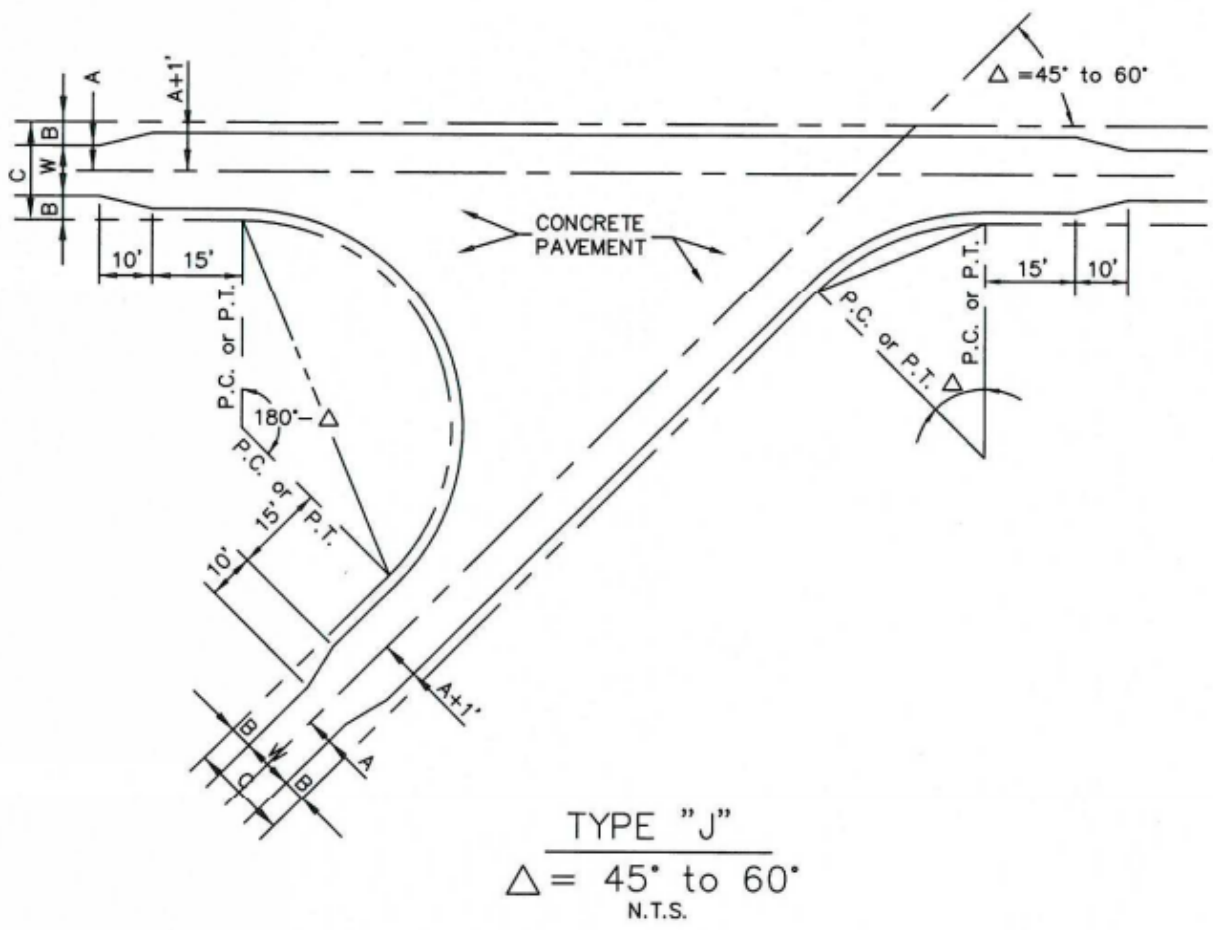
303.5

DATE


Mar. 2018

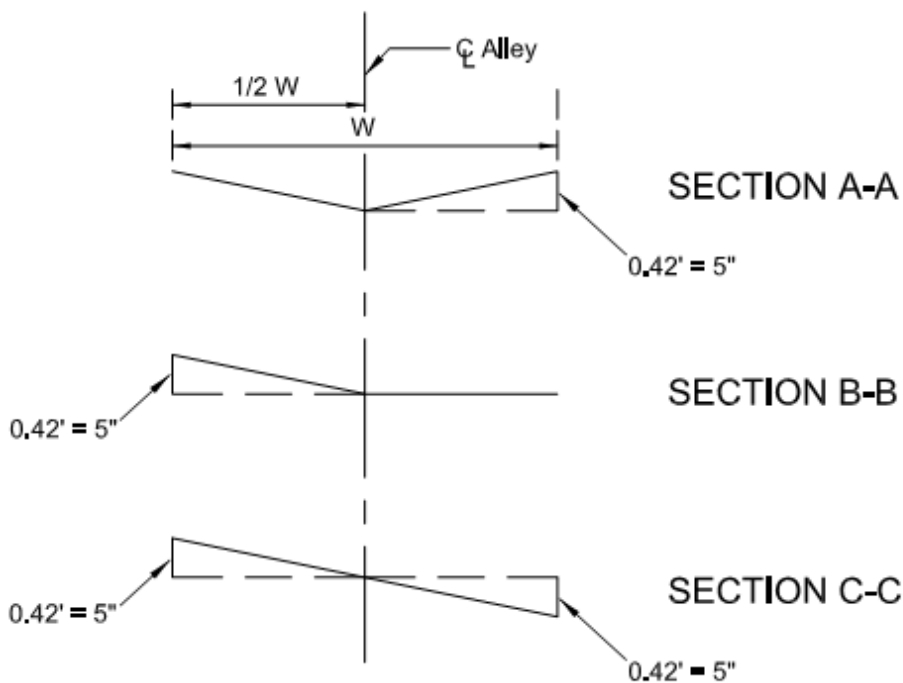
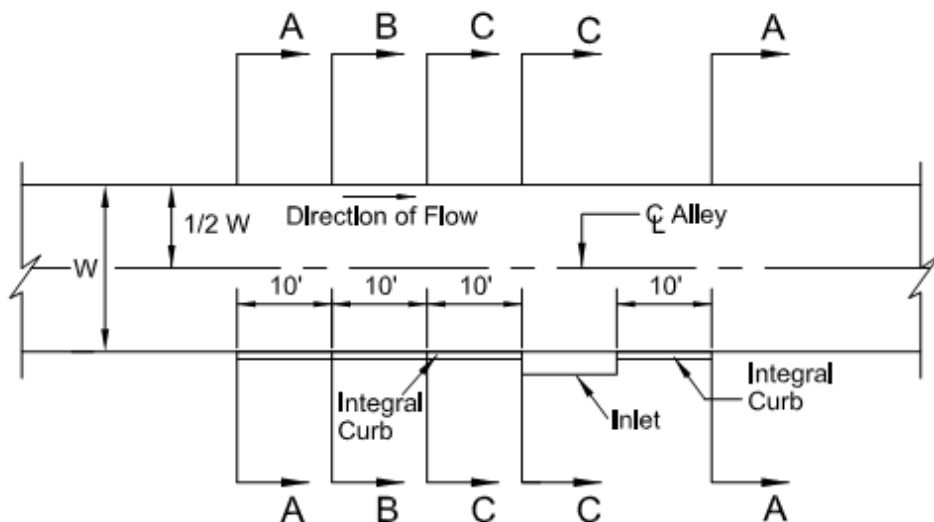
STANDARD DRAWING NO.

R-2240




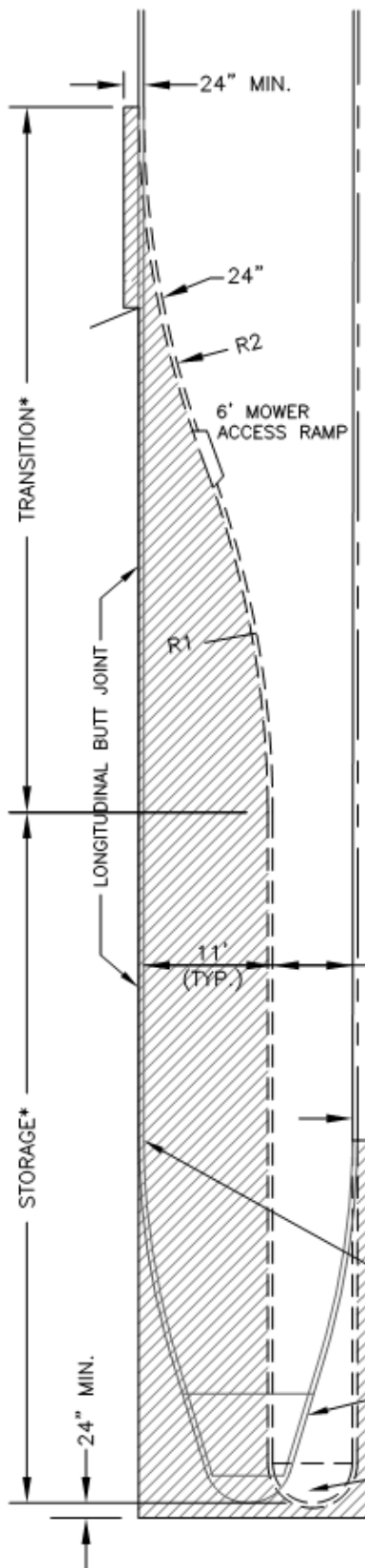
- NOTES:
1. ALLEY WIDTH SHALL BE TWELVE (12') FEET MINIMUM.
  2. ALLEY R.O.W. SHALL BE TWENTY (20') FEET MINIMUM.
  3. DIMENSION A= SIX (6') FEET.
  4. DIMENSION B= FOUR (4') FEET.

ALLEY GEOMETRICS	CITY OF ROCKWALL	STANDARD SPECIFICATION REFERENCE 303.5	
TYPE "J"		DATE Mar. 2018	STANDARD DRAWING NO. R-2250



TYPICAL ALLEY WARPING AT INLET  
(Not to Scale)

ALLEY GEOMETRICS	CITY OF ROCKWALL		
ALLEY WARPING AT INLET		DATE OCT. '17	DRAWING NO. R-2251



NOTES:

1. ALL DIMENSIONS ARE TO BACK OF CURB UNLESS OTHERWISE NOTED.
2. NO CONCRETE REPLACEMENT WIDTH SHALL BE LESS THAN 24".
3. PAVEMENT SECTION SHALL MATCH THAT OF EXISTING STREET.
4. ALL TIEBARS FOR LONGITUDINAL CONSTRUCTION JOINTS SHALL BE MACHINE DRILLED. NO HAND DRILLING ALLOWED.
5. IF MEDIAN WIDTH  $\leq 7'$  (FACE TO FACE) THEN 6" THICK REINFORCED INTEGRAL STAINED AND STAMPED COLOR CONCRETE MEDIAN PAVEMENT SHALL BE INSTALLED.
6. ALL SAWCUTS TO BE FULL DEPTH AND EITHER PERPENDICULAR AND/OR PARALLEL WITH STREET CENTERLINE. NO ANGLED OR CURVED SAWCUTS ALLOWED.
7. WHEN SAWCUT EXCEEDS HALF OF CONSTRUCTION JOINT PANEL WIDTH, FULL PANEL REMOVAL AND REPLACEMENT SHALL BE REQUIRED.
8. TYPICAL R1/R2 VALUES:  
 250' TYP. FOR SINGLE TURN LANE  
 250' TYP. FOR DUAL TURN LANE
9. MUST MATCH JOINTS OF ADJACENT TRAFFIC LANES

\* REFER TO CONSTRUCTION DRAWINGS FOR STORAGE, TRANSITION AND RADII DIMENSIONS.

SEE NOTE #5

LEFT TURN LANE

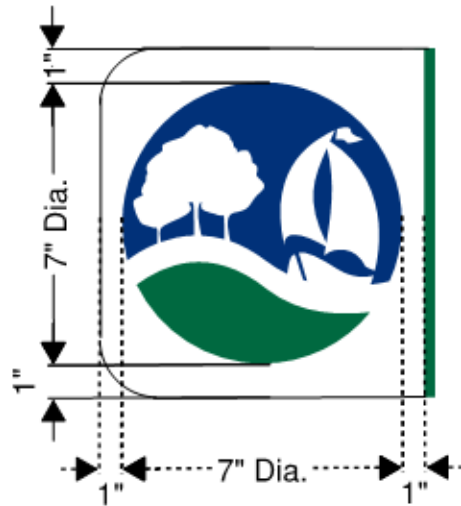
CITY OF ROCKWALL



CONCRETE REMOVAL & REPLACEMENT

DATE	DRAWING NO.
AUG. '19	R-2270





*Rockwall Logo Detail*

NOT TO SCALE

Notes:

1. Street name blades shall consist of white SCOTCHLITE 3930 High Intensity Prismatic Material, digitally printed using HP Latex 360 or higher.  
 Green: Pantone 335C with overlay CMYK 100-0-20-0 set to darken.  
 Blue: Pantone 287C.


2. Lettering to be composed of a combination of upper and lowercase letters, with initial uppercase letters. Font to be Clearview TCAD-1w with uppercase to be 6" Min. height and lowercase to be 4.5" Min. height. No more than 65% compression on font width.

3. Lettering for street designations and block numbers to be composed of initial uppercase letters at least 3" Min. height and lower-case letters at least 2.25" Min. height.

4. Sign post to be 2 3/8" O.D. galvanized steel tube sign pole.

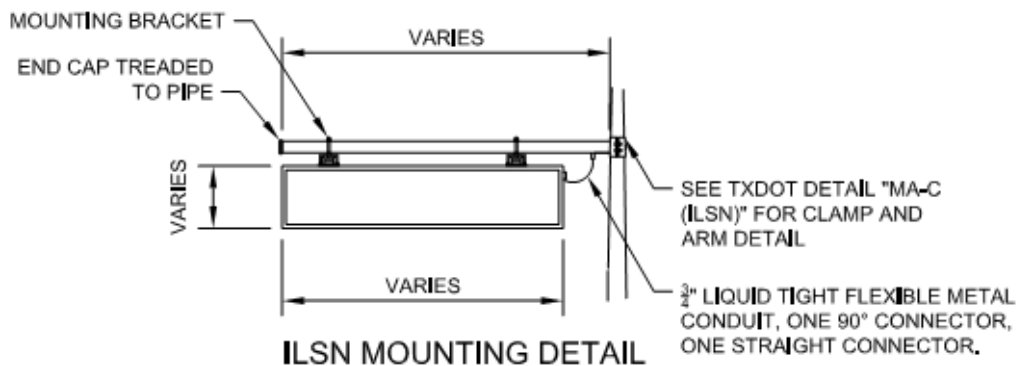
***STREET SIGN DETAIL***

NOT TO SCALE

STREET REGULATORY SIGNAGE	CITY OF ROCKWALL		
TYPICAL STREET SIGN DETAIL		DATE May 2018	DRAWING NO. R-2300




**EXAMPLE SINGLE STREET NAME DETAIL**

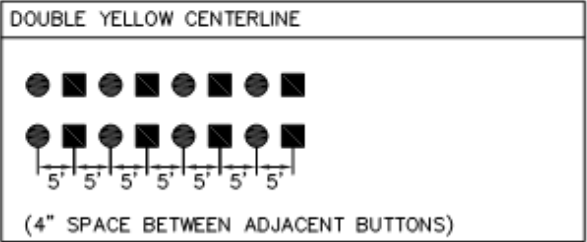
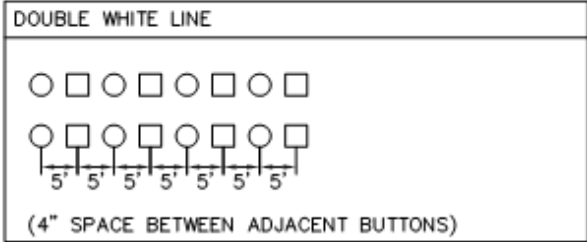
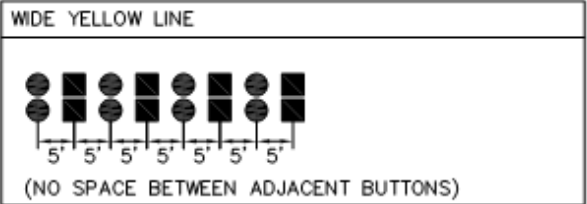
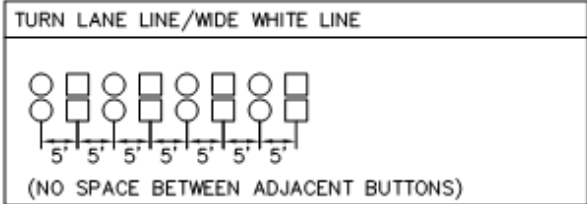
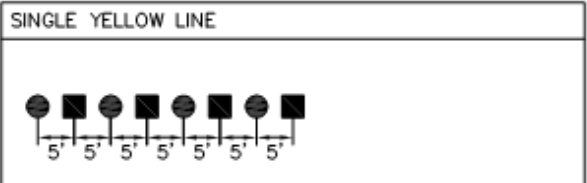
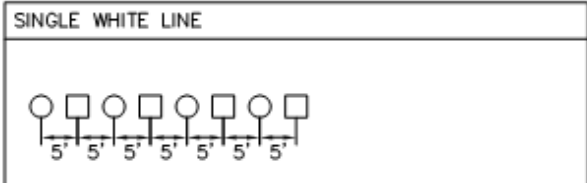
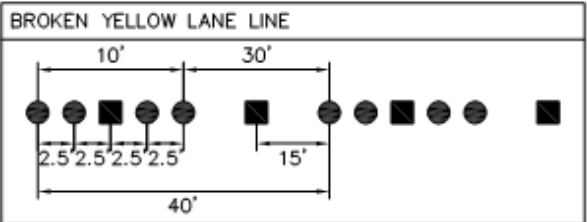
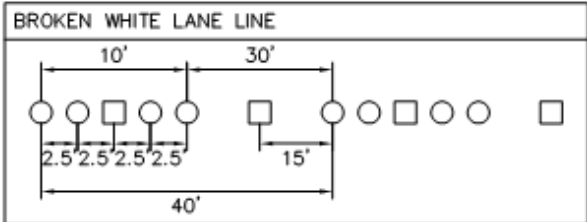


**ILSN MOUNTING DETAIL**

**NOTES:**

1. UNLESS OTHERWISE SPECIFIED, ALL LETTER SPACING AND WIDTH SHALL BE 100% OF THE US DOT MINIMUM RECOMMENDATION.
  - A. LEGENDS REQUIRING LENGTHS GREATER THAN THE 96" WIDTH OF THE SIGN USING STANDARD SPACING, MAY BE ADJUSTED TO FIT.
2. ILSNS UP TO 6' IN LENGTH MAY BE PLACED ON A 7' ILSN CLAMP-ON ARM, ILSNS UP TO 8' IN LENGTH MAY BE PLACED ON A 9' ILSN CAMP-ON ARM.
3. LETTERING SIZE AND SPACING BETWEEN THE VARIOUS SIGN ELEMENTS SHALL FOLLOW THE CURRENT VERSION OF THE STANDARD HIGHWAY SIGN DESIGNS FOR TEXAS MANUAL FOR D3-1.
  - A. DESIRED LETTER HEIGHT FOR STREET NAME SIGNS SHALL BE 12" FOR UPPER CASE LETTERS. STREET NAME LETTER HEIGHT MAY BE REDUCED TO 10" TO REDUCE THE SIZE OF THE SIGN AS NEEDED.
4. THE CITY LOGO HEIGHT SHALL MATCH MAXIMUM TEXT SIZE HEIGHT ON SIGN LEGEND. THE LOGO SHALL BE PLACED ON THE LEFT SIDE OF EACH SIDE OF THE SIGN ON A WHITE BACKGROUND.
5. THE ILSN LEGEND MAY BE COMPOSED OF ONE LINE OR TWO LINES OF TEXT. CONTRACTOR TO VERIFY WITH CITY BEFORE SUBMITTING SHOP DRAWINGS FOR SIGNS WITH TWO LINES OF TEXT.
6. SIGNS SHALL BE EDGELIT LED ILLUMINATED
7. FACE COLOR/MATERIAL: GREEN EC FILM OVER HIGH-INTENSITY TRANSLUCENT REFLECTIVE WHITE SHEETING ON UV LEXAN.
8. FRAME WIDTH TO BE PROVIDED BY MANUFACTURER.
9. SIGN BODIES AND DOORS ARE TO BE POWDER COATED GLOSSY BLACK.
10. SIGNS SHALL BE SINGLE SIDED EXCEPT UNDER THE FOLLOWING CONDITION:
  - A. SIGN SHALL BE DOUBLE SIDED IF BOTH APPROACHES FACING THE SIGN ARE UNDIVIDED (NO MEDIUM).
11. SIGNS SHALL BE TOP MOUNTED USING STANDARD TXDOT DETAILS.
12. ILSN SHALL BE MOUNTED ON A STANDARD TXDOT ILSN CLAMP-ON ARM UNLESS OTHERWISE DIRECTED IN THE PLANS
13. ILSN SHALL BE FULLY GASKETED AND WATERTIGHT.
14. TRAFFIC SIGNAL POLE SHALL BE AT LEAST 24' HEIGHT. (SEE TXDOT TRAFFIC SIGNAL POLE STANDARDS)
15. A SEPARATE PHOTOCCELL FOR ILSN/120 VOLT CIRCUIT WILL BE REQUIRED.
16. TWO #8 XHHW CONDUCTORS SHALL BE INSTALLED FROM SERVICE TO TERMINAL BLOCK OF EACH POLE WITH ILSN UNLESS OTHERWISE SHOWN IN THE PLANS. (CONDUCTORS FROM SERVICE TO TERMINAL BLOCK OF EACH POLE SHALL BE PAID FOR SEPARATELY FROM THE ILSN PAY ITEM.)
  - A. DAISY CHAIN ALL ILSNS UNLESS OTHERWISE DIRECTED IN THE PLANS.
17. TWO #12 XHHW CONDUCTORS SHALL BE INSTALLED FROM TERMINAL BLOCK OF POLE TO ILSN UNLESS OTHERWISE SHOWN IN THE PLANS. (CONDUCTORS FROM THE TERMINAL BLOCK OF EACH POLE TO ILSN SHALL BE PAID FOR SEPARATELY FROM THE ILSN PAY ITEM.)
18. CONTRACTOR TO SUBMIT SHOP DRAWINGS OF THE LED ILSNS TO CITY OF ROCKWALL FOR APPROVAL PRIOR TO FABRICATION.
19. CONTRACTOR SHALL BE RESPONSIBLE FOR ALL EQUIPMENT NECESSARY TO INSTALL THE ILSN SIGN.
20. ALL ILSNS SHALL FOLLOW ALL RULES AND GUIDELINES AS SPECIFIED IN THE MOST RECENT EDITIONS OF THE STANDARD HIGHWAY SIGN DESIGNS FOR TEXAS AND THE TEXAS MANUAL ON UNIFORM TRAFFIC CONTROL DEVICES. SHOULD ANY CONFLICTS BETWEEN THE ABOVE NOTES AND THESE DOCUMENTS, THESE DOCUMENTS SHALL GOVERN.

ILLUMINATED STREET NAME SIGN	CITY OF ROCKWALL		
ILSN SIGN DETAIL		DATE JUN '17	DRAWING NO. R-2310



- NOTES:
- UNLESS OTHERWISE NOTED, THE FOLLOWING BUTTON TYPES SHALL BE USED:
- = 4" ROUND YELLOW CERAMIC NON-REFLECTIVE BUTTON
  - = 4" SQUARE YELLOW/YELLOW ACRYLIC REFLECTIVE BUTTON
  - = 4" ROUND WHITE CERAMIC NON-REFLECTIVE BUTTON
  - = 4" SQUARE CLEAR/RED ACRYLIC REFLECTIVE BUTTON

**RAISED PAVEMENT MARKINGS**

**LANE LINES**

**CITY OF ROCKWALL**

STANDARD SPECIFICATION REFERENCE	
DATE	STANDARD DRAWING NO.
Mar. 2018	R-2320



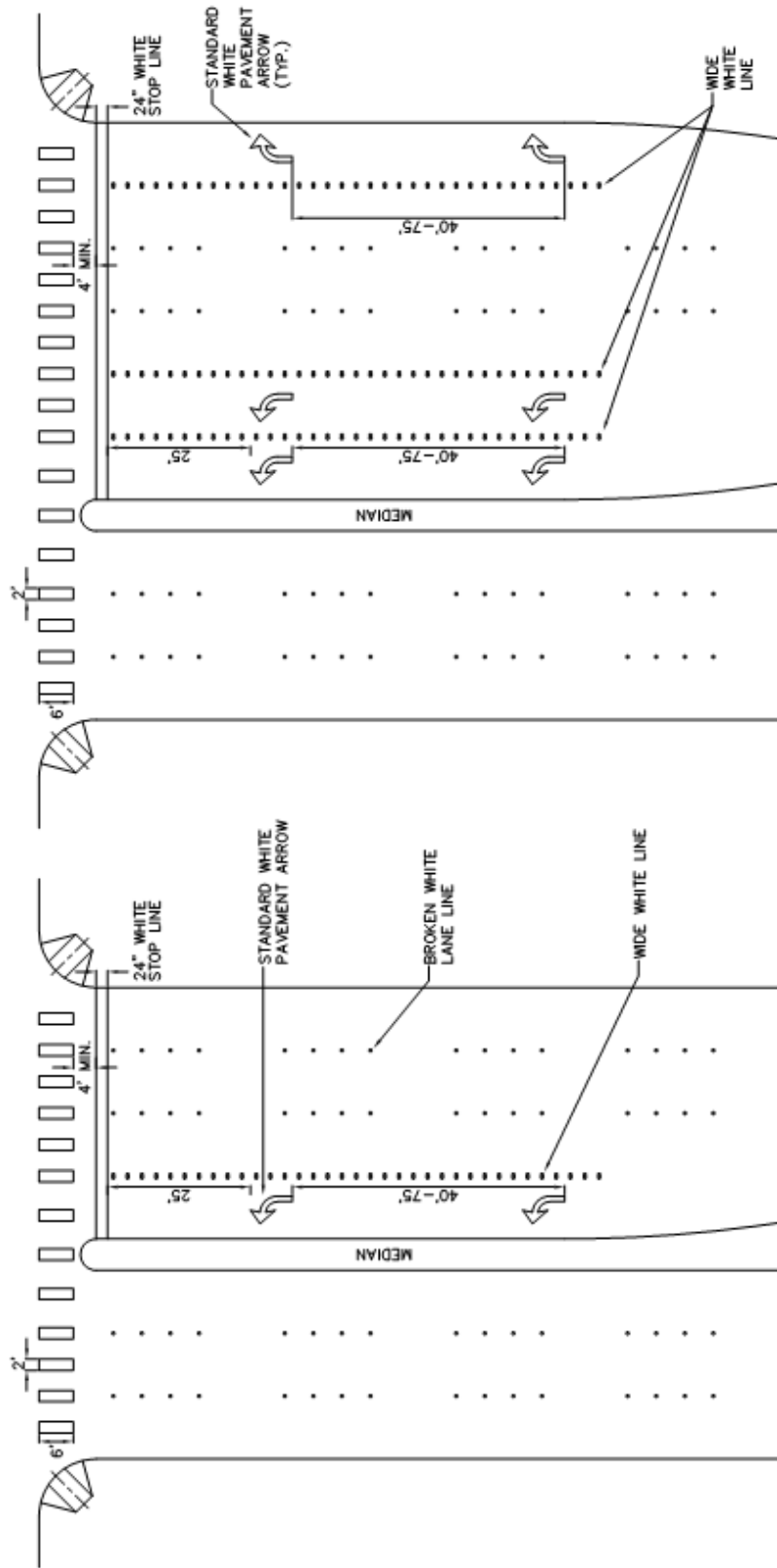
<p><b>WHITE CHEVRON LANE</b></p> <p>ALTERNATING BUTTONS (AB)</p> <p>ALTERNATING LINES (AL)</p>	<p><b>YELLOW CHEVRON LANE</b></p> <p>ALTERNATING BUTTONS (AB)</p> <p>ALTERNATING LINES (AL)</p>	<p><b>WHITE CROSS HATCH LINE</b></p> <p>ALTERNATING BUTTONS (AB)</p> <p>ALTERNATING LINES (AL)</p>	<p><b>YELLOW CROSS HATCH LINE</b></p> <p>ALTERNATING BUTTONS (AB)</p> <p>ALTERNATING LINES (AL)</p>				
<p><b>RAISED PAVEMENT MARKINGS</b></p> <p><b>CHEVRON AND CROSSHATCH</b></p>		<p><b>CITY OF ROCKWALL</b></p>	<p>STANDARD SPECIFICATION REFERENCE</p> <table border="1"> <tr> <td>DATE</td> <td>STANDARD DRAWING NO.</td> </tr> <tr> <td>Mar. 2018</td> <td>R-2330</td> </tr> </table>	DATE	STANDARD DRAWING NO.	Mar. 2018	R-2330
DATE	STANDARD DRAWING NO.						
Mar. 2018	R-2330						

**NOTES:**  
 UNLESS OTHERWISE NOTED, THE FOLLOWING BUTTON TYPES SHALL BE USED:

- = 4" ROUND YELLOW CERAMIC NON-REFLECTIVE BUTTON
- = 4" SQUARE YELLOW/YELLOW ACRYLIC REFLECTIVE BUTTON
- = 4" ROUND WHITE CERAMIC NON-REFLECTIVE BUTTON
- = 4" SQUARE CLEAR/RED ACRYLIC REFLECTIVE BUTTON

FOR CHEVRON AND CROSS-HATCH LINES, THE FOLLOWING DIMENSIONS WILL BE NOTED ON THE PLANS.

B = THE DISTANCE BETWEEN ADJACENT BUTTONS ON A LINE (MEASURED ALONG A LINE PERPENDICULAR TO THE BUTTONED AREA, NOT ALONG THE 45 DEGREE LINE)



DUAL LEFT TURN LANE & RIGHT TURN LANE

TYPICAL APPROACH

RAISED PAVEMENT MARKINGS  
INTERSECTION APPROACH

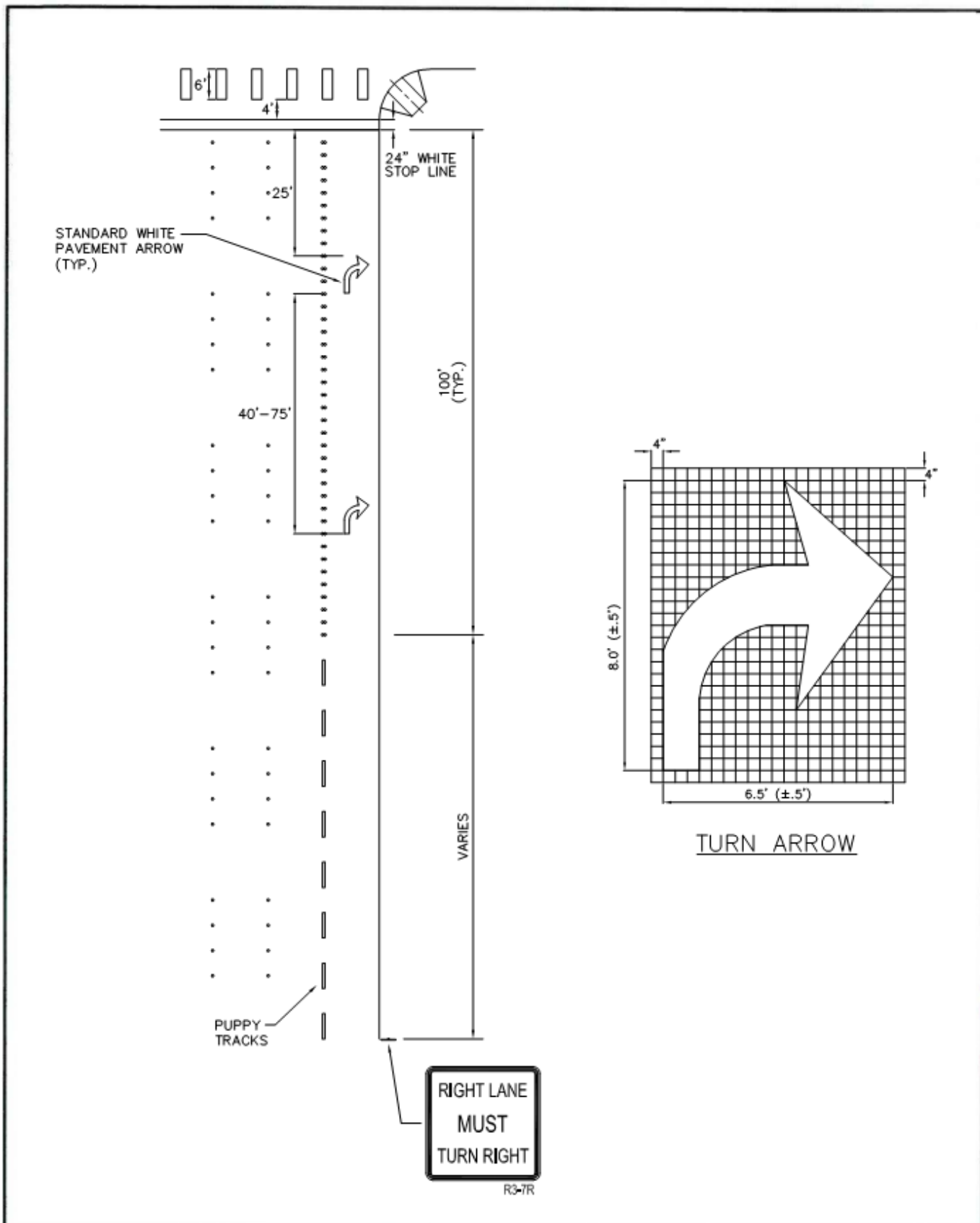
CITY OF ROCKWALL




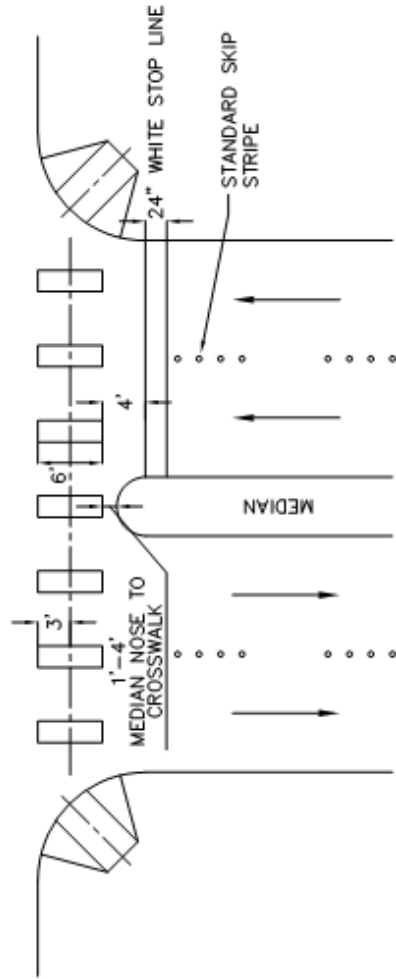
STANDARD SPECIFICATION REFERENCE

DATE  
Mar. 2018

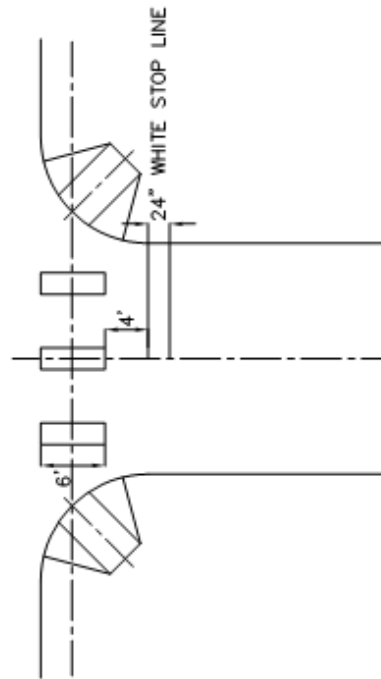
STANDARD DRAWING NO.  
R-2340



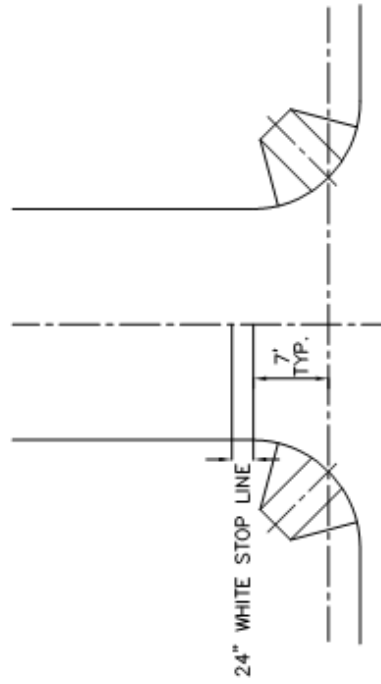
TYPE C INTERSECTION	CITY OF ROCKWALL	STANDARD SPECIFICATION REFERENCE	
RIGHT LANE DROP MARKINGS		DATE	STANDARD DRAWING NO.
		Mar. 2018	R-2350



TYPICAL LAYOUT  
TYPE D THOROUGHFARE  
STOP LINE WITH CROSSWALK



TYPICAL LAYOUT  
TYPE F&G THOROUGHFARE  
CROSSWALK WITH STOP LINE



TYPICAL LAYOUT  
TYPE F&G THOROUGHFARE  
STOP LINE WITHOUT CROSSWALK

TYPICAL THOROUGHFARE  
LAYOUTS

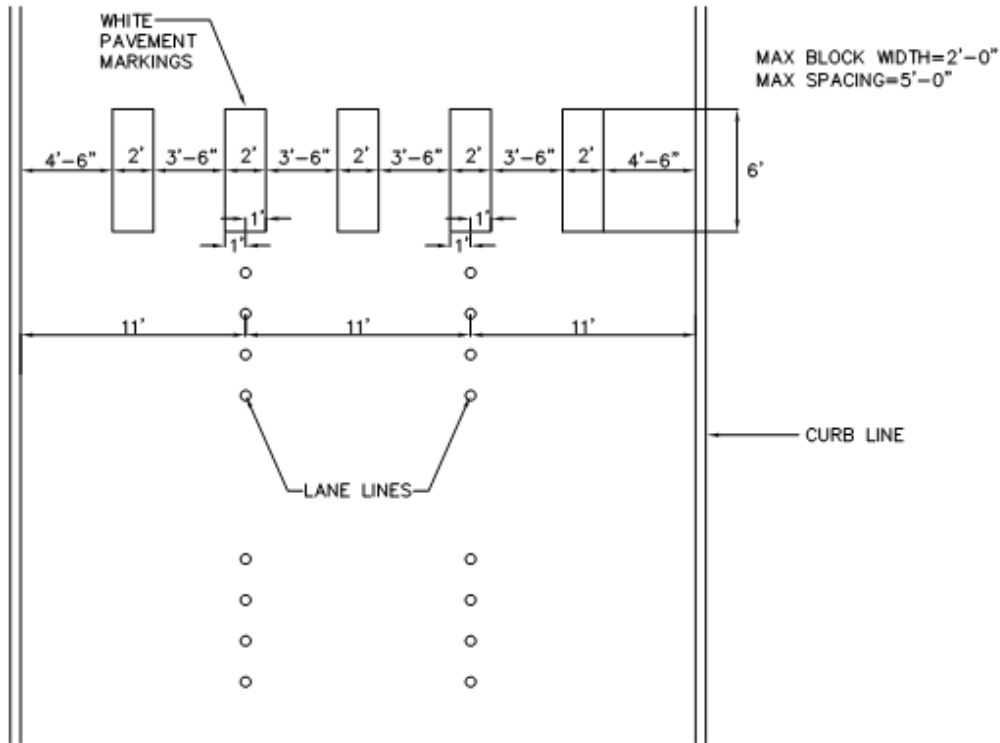
CITY OF ROCKWALL



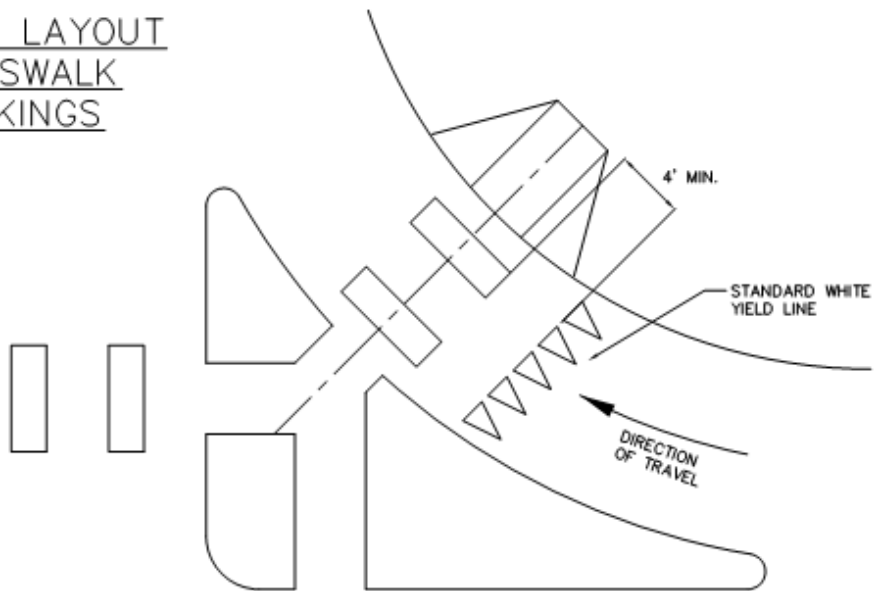
STANDARD SPECIFICATION REFERENCE

DATE  
Mar. 2018


STANDARD DRAWING NO.  
R-2360



TYPICAL LAYOUT  
CROSSWALK  
MARKINGS



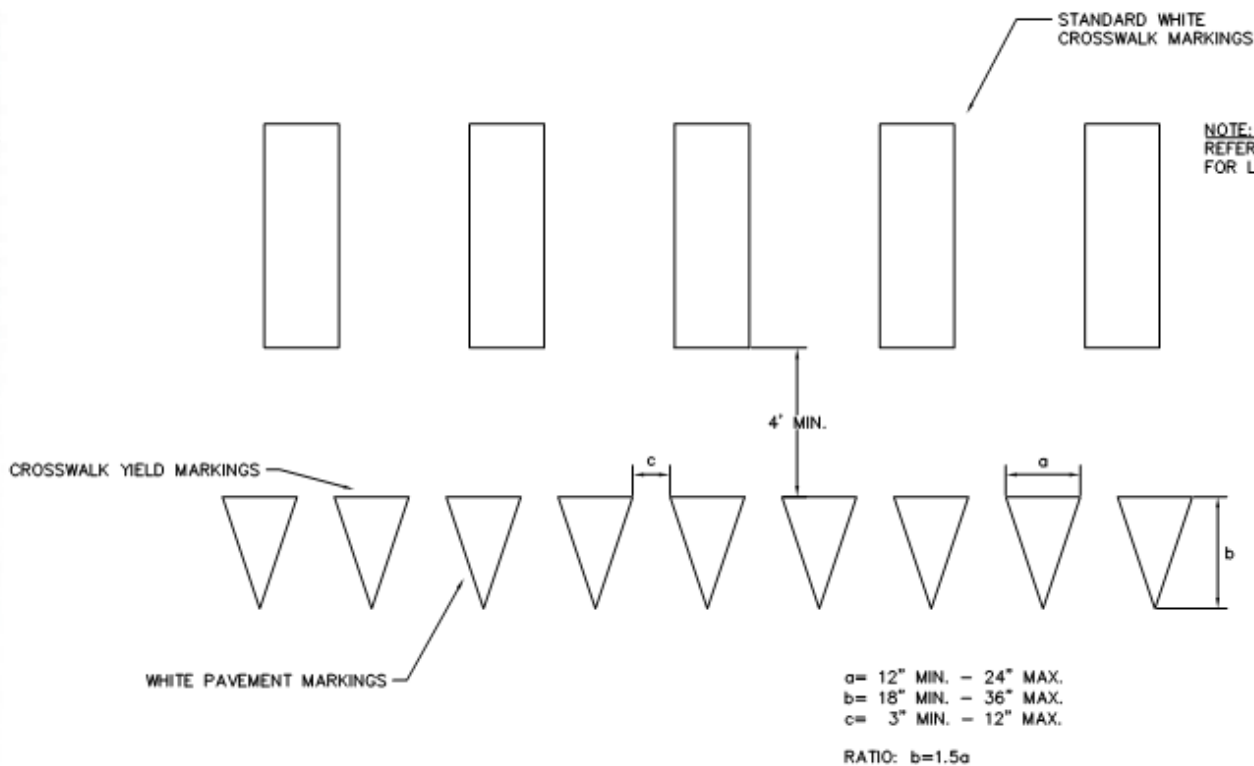
TYPICAL LAYOUT  
CHANNELIZING ISLAND  
YIELD LINE WITH CROSSWALK

<p>TYPICAL CROSSWALK LAYOUTS</p>	<p>CITY OF ROCKWALL</p> 	<p>STANDARD SPECIFICATION REFERENCE</p>	
		<p>DATE Mar. 2018</p>	<p>STANDARD DRAWING NO. R-2370</p>

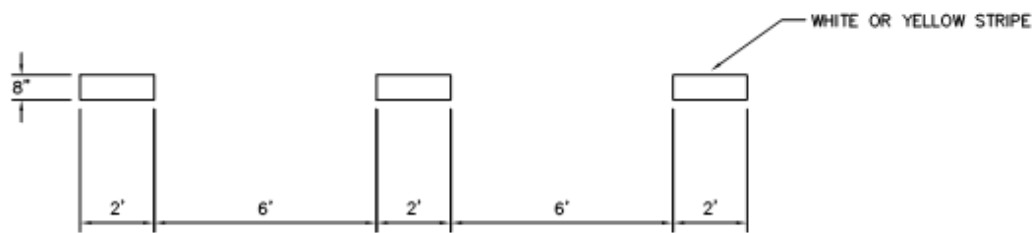




NOTE:  
REFER TO T43  
FOR LAYOUT



CROSSWALK MARKINGS



DASH LINE ("PUPPY TRACK") MARKINGS

TYPICAL CROSSWALK AND  
DASHED MARKINGS

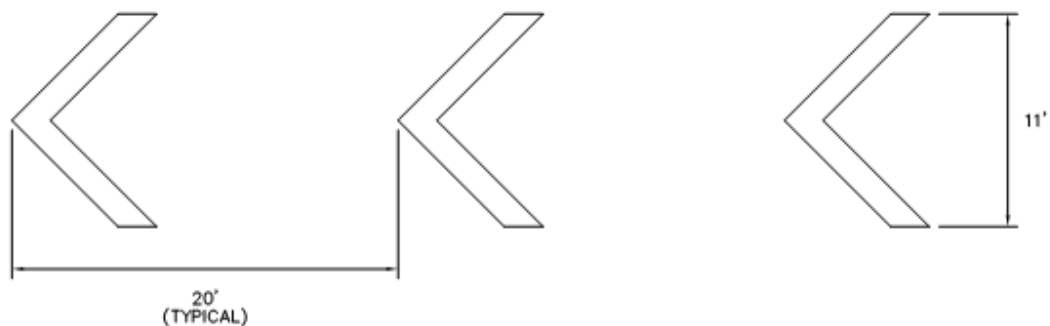
CITY OF ROCKWALL



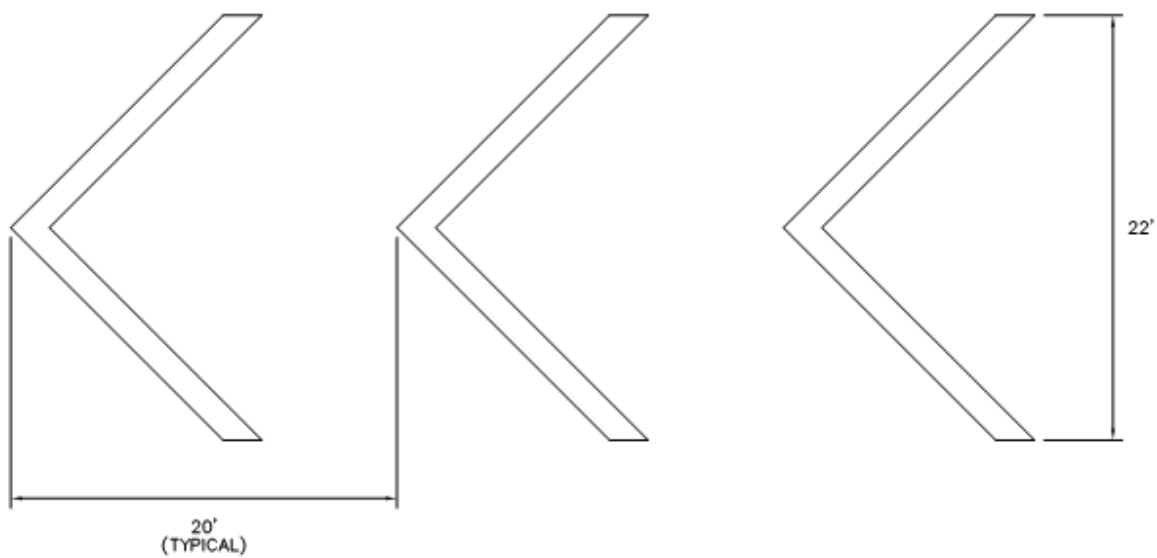
STANDARD SPECIFICATION REFERENCE

DATE  
Mar. 2018

STANDARD DRAWING NO.  
R-2380



11' WIDE CHEVRON STRIPE



22' WIDE CHEVRON STRIPE

CHEVRON STRIPING

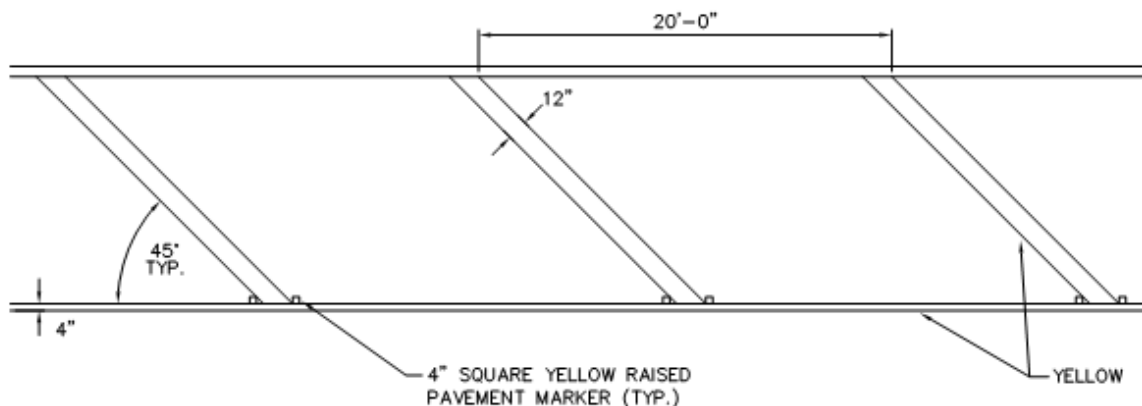
CITY OF ROCKWALL

STANDARD SPECIFICATION REFERENCE

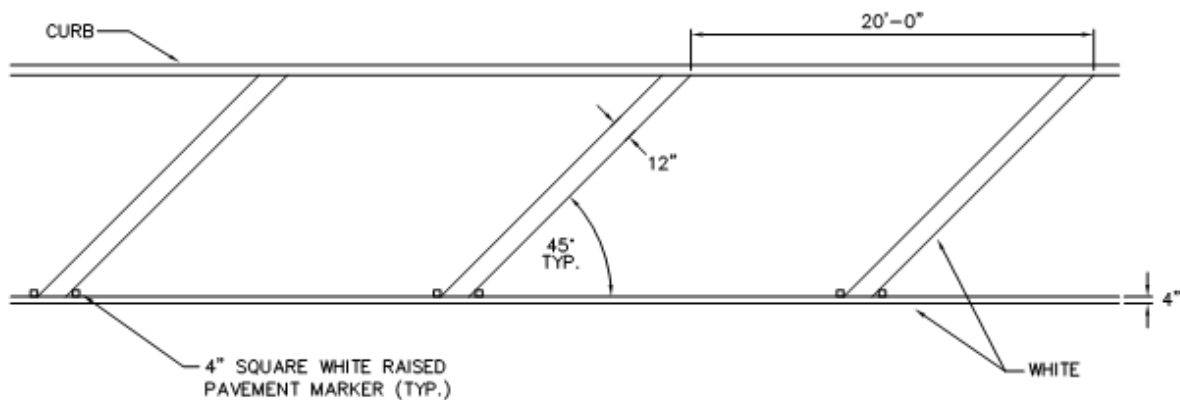


DATE  
Mar. 2018

STANDARD DRAWING NO.  
R-2390



DIRECTION OF TRAVEL →



← DIRECTION OF TRAVEL

DIAGONAL CROSSHATCH  
STRIPING

CITY OF ROCKWALL



STANDARD SPECIFICATION REFERENCE

DATE  
Mar. 2018

STANDARD DRAWING NO.  
R-2400



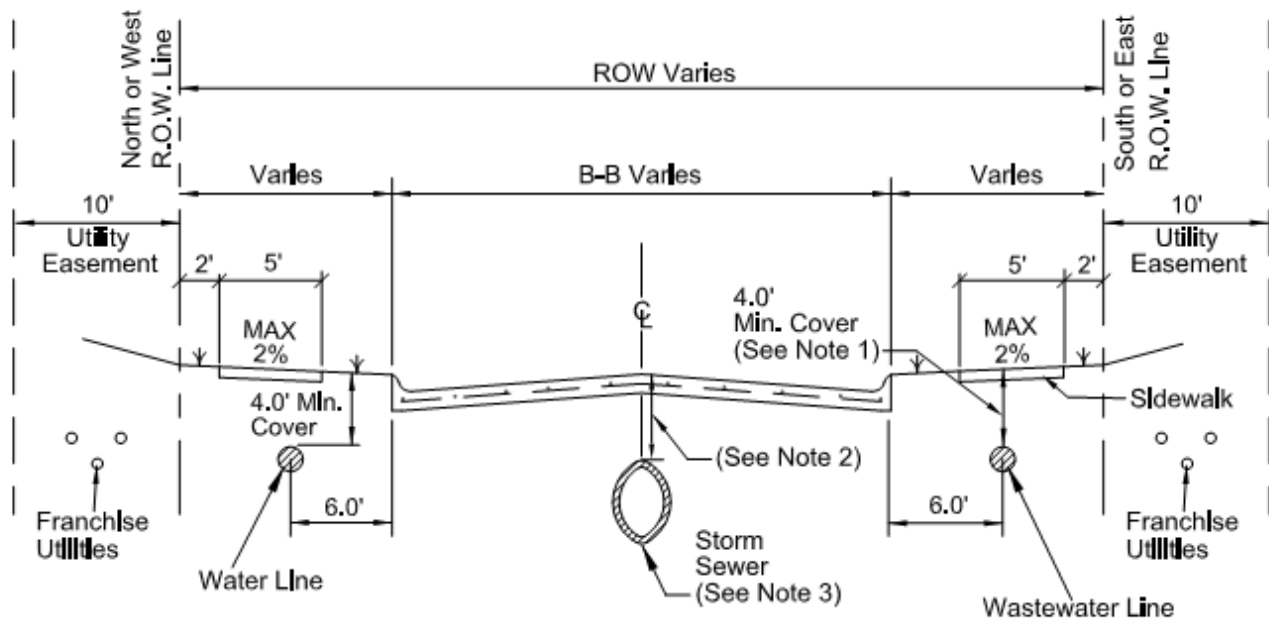


SECTION 8.03 | DIVISION 3000. GENERAL UNDERGROUND CONDUIT

TABLE 8.3: REVISIONS TO NCTCOG'S DIVISION 3000 GENERAL UNDERGROUND CONDUIT

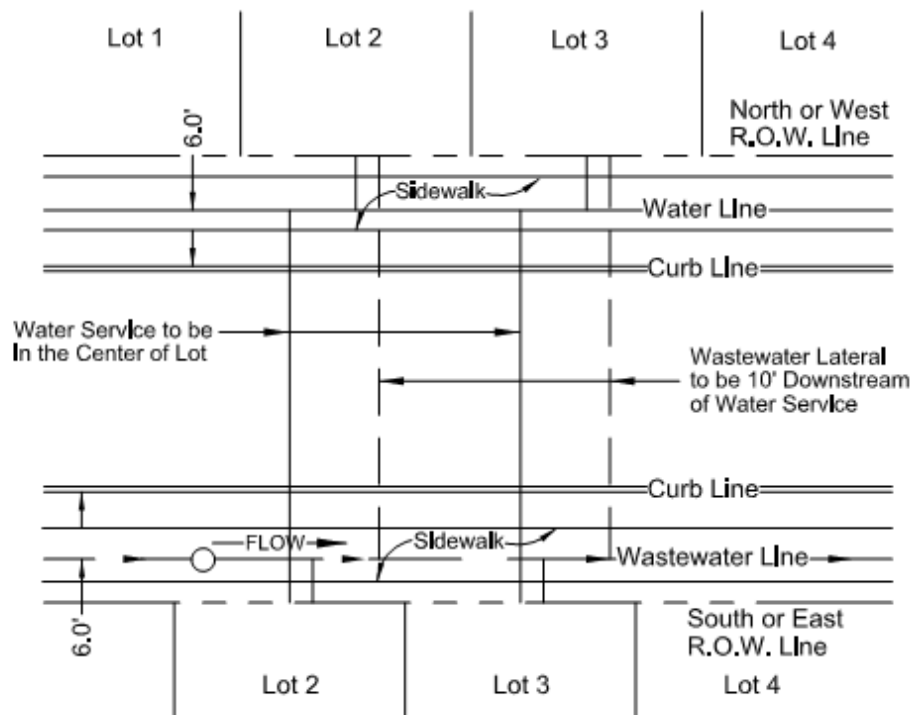
NOTES: (1) DELETED NCTCOG DRAWING; (2) REVISED NCTCOG DRAWING (SEE REVISIONS BELOW); (3) ADDED ROCKWALL STANDARD DRAWING (SEE DRAWING BELOW); AND (4) ADDED CURRENT TXDOT STANDARDS

REVISED	DRAWING NO.	DESCRIPTION
(3)	R-3000	UTILITIES LOCATION DETAIL
(1)	3010	EMBEDMENT – CLASS "A" & "A-1"
(3)	R-3010	EMBEDMENT – CLASS "A" & "A-1"
(1)	3020	EMBEDMENT – CLASS "B", "B+" & "B-1"
(3)	R-3020	EMBEDMENT – CLASS "B", "B+" & "B-1"
(1)	3030	EMBEDMENT – CLASS "B-2", "B-3" & "B-4"
(3)	R-3030	EMBEDMENT – CLASS "B-2", "B-3" & "B-4"
(1)	3040	EMBEDMENT – CLASS "C", "C+" & "C-1"
(3)	R-3040	EMBEDMENT – CLASS "C", "C+" & "C-1"
(1)	3050	EMBEDMENT – CLASS "D+" & "G"
(3)	R-3050	EMBEDMENT – CLASS "D+" & "G"
(1)	3060	EMBEDMENT – CLASS "G-1" & "H"
(3)	R-3060	EMBEDMENT – CLASS "G-1" & "H"
(1)	3070A	PAVEMENT CUT AND REPAIR – CONCRETE AND PARKWAY
(3)	R-3070A	PAVEMENT CUT AND REPAIR – CONCRETE AND PARKWAY
(1)	3070B	PAVEMENT CUT AND REPAIR – ASPHALT
(3)	R-3070B	PAVEMENT CUT AND REPAIR – ASPHALT
(1)	3070C	PAVEMENT CUT AND REPAIR – EXTENT –RESIDENTIAL
(1)	3070D	PAVEMENT CUT AND REPAIR – EXTENT - MULTIPLE LANES
(1)	3080	INFILTRATION PROTECTION – CONDUIT UNDER CHANNEL
(3)	R-3090	UNDERGROUND CONDUIT – STEEL ENCASED BORE




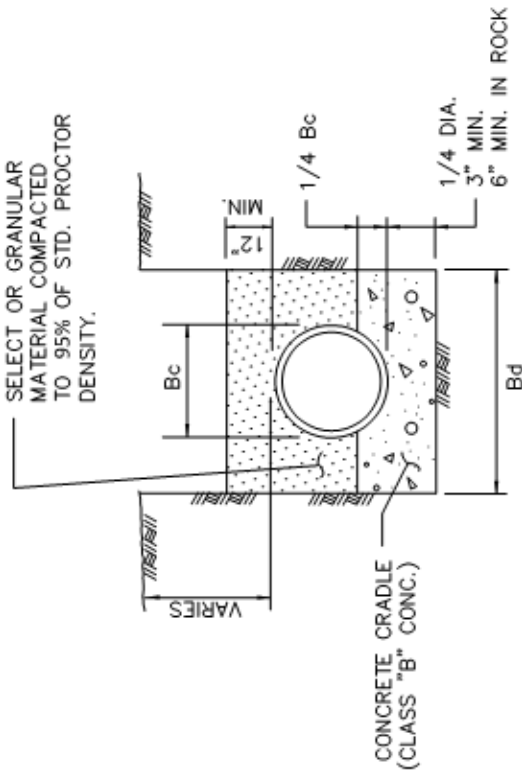
**NOTE:**

1. If wastewater line has a cover greater than ten feet (10') than pipe shall be minimum SDR 26 and no services allowed.
2. If cover is two (2) feet or less than Class IV RCP is required.
3. Horizontal location of storm sewer for divided roads to be determined by design engineer. Not to be placed in the parkway.



**UTILITY SERVICE DETAIL**

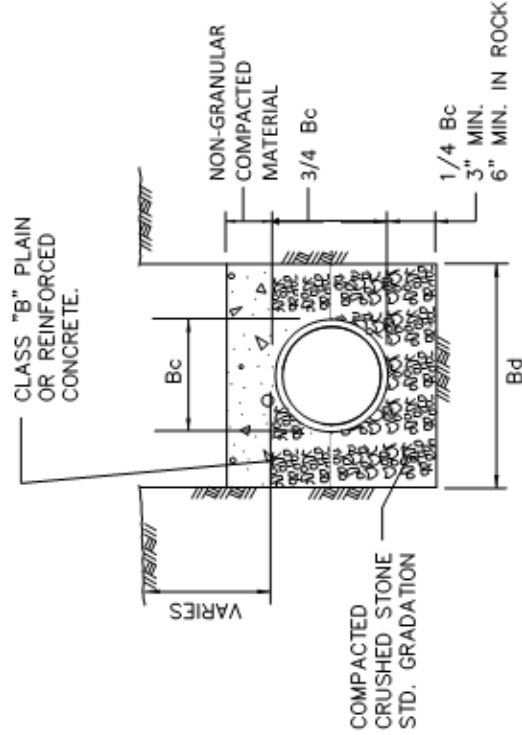
GENERAL UNDERGROUND CONDUIT	CITY OF ROCKWALL		
UTILITIES LOCATION DETAIL		DATE OCT. '17	DRAWING NO. R-3000



CLASS "A"

CLASS "B" CONCRETE CRADLE  
PLAIN CONC. LF 2.8  
REINF. CONC. LF 3.4 P=0.4%

N.T.S.



CLASS "A-1"

CLASS "B" CONCRETE CAP  
PLAIN CONC. LF 2.8  
REINF. CONC. LF 3.4 P=0.4%  
REINF. CONC. LF 4.8 P=1.0%

N.T.S.

NOTES:

1. LF. = LOAD FACTOR TO BE USED TO DETERMINE 3 EDGE BEARING BASED ON TYPE OF EMBEDMENT.
2. FREE-FALL OF CONCRETE NOT TO EXCEED 5 FT. MAXIMUM.
3. P = Rho FOR STEEL %
4. Bc = OUTSIDE DIAMETER OF PIPE
5. Bd = TRENCH WIDTH

STANDARD DRAWING NO.  
3010

EMBEDMENT

CLASS "A" & "A-1"

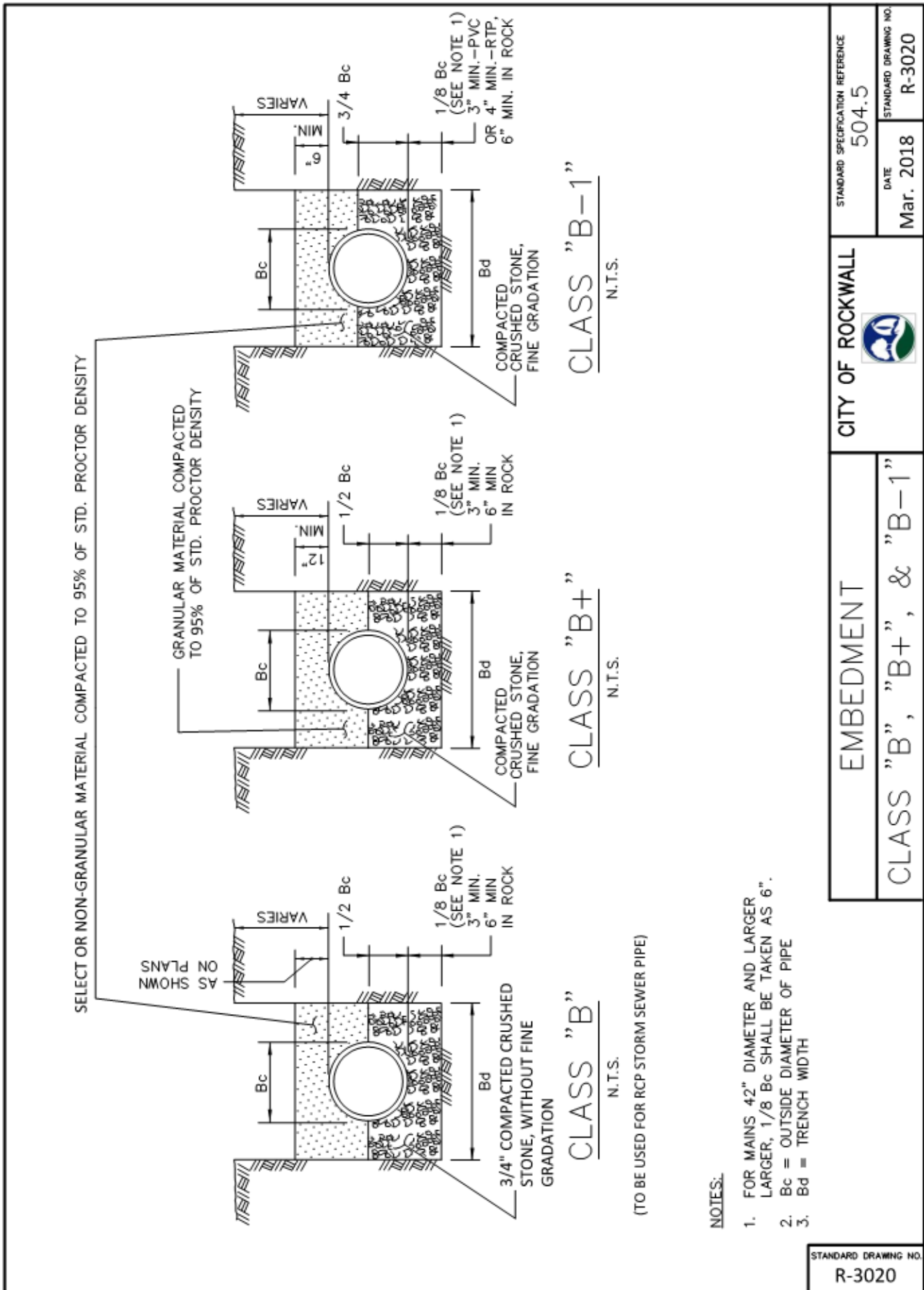
CITY OF ROCKWALL



STANDARD SPECIFICATION REFERENCE  
504.5

DATE  
Mar. 2018

STANDARD DRAWING NO.  
R-3010



STANDARD SPECIFICATION REFERENCE	504.5
DATE	Mar. 2018
STANDARD DRAWING NO.	R-3020

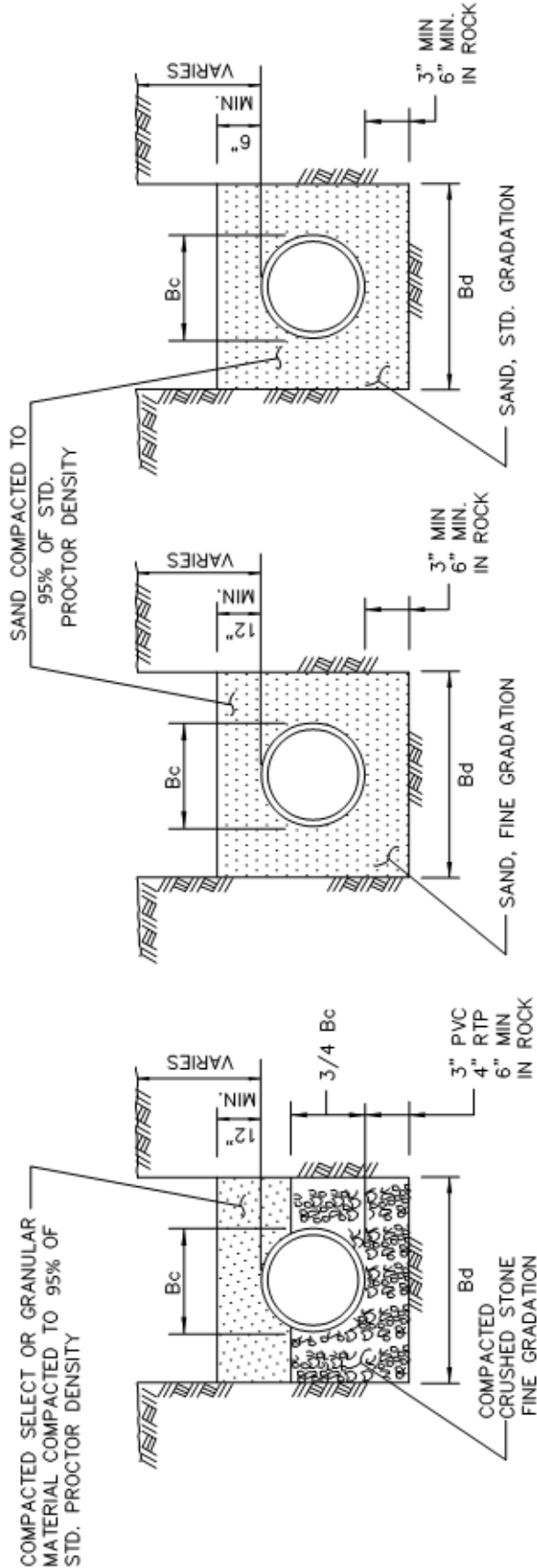
CITY OF ROCKWALL

EMBEDMENT

CLASS "B", "B+", & "B-1"

STANDARD DRAWING NO.	R-3020
----------------------	--------





CLASS "B-2"

N.T.S.

CLASS "B-3"

N.T.S.

CLASS "B-4"

N.T.S.

(TO BE USED FOR PVC WATER PIPE AND PVC WASTE WATER FORCE MAIN PIPE)

NOTES:

1. Bc = OUTSIDE DIAMETER OF PIPE
2. Bd = TRENCH WIDTH
3. NO GRANULAR MATERIAL ABOVE ROCK OR STONE EMBEDMENT

STANDARD DRAWING NO.  
3030

EMBEDMENT



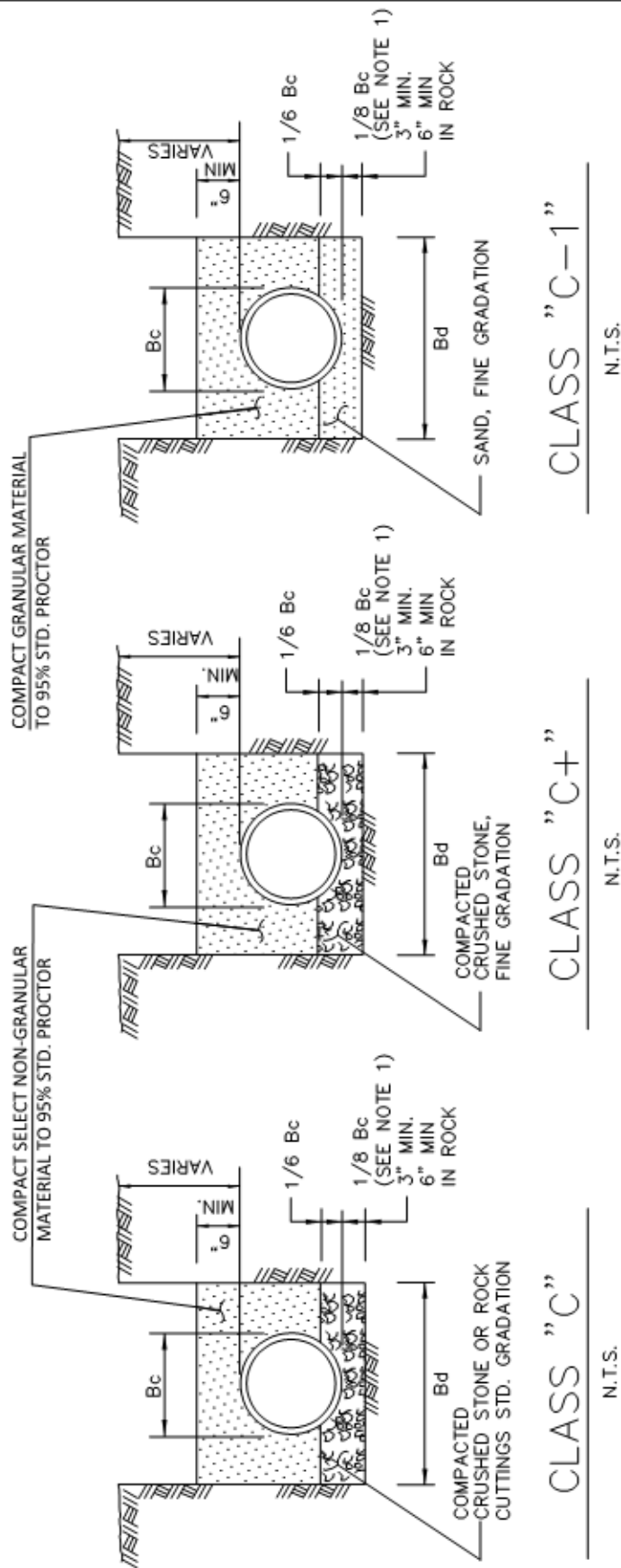
CITY OF ROCKWALL

STANDARD SPECIFICATION REFERENCE  
504.5

CLASS "B-2", "B-3", & "B-4"

DATE  
AUG. '19

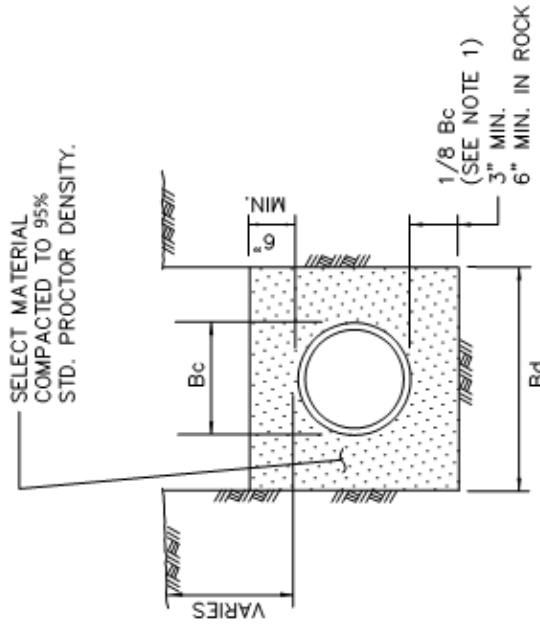
STANDARD DRAWING NO.  
R-3030



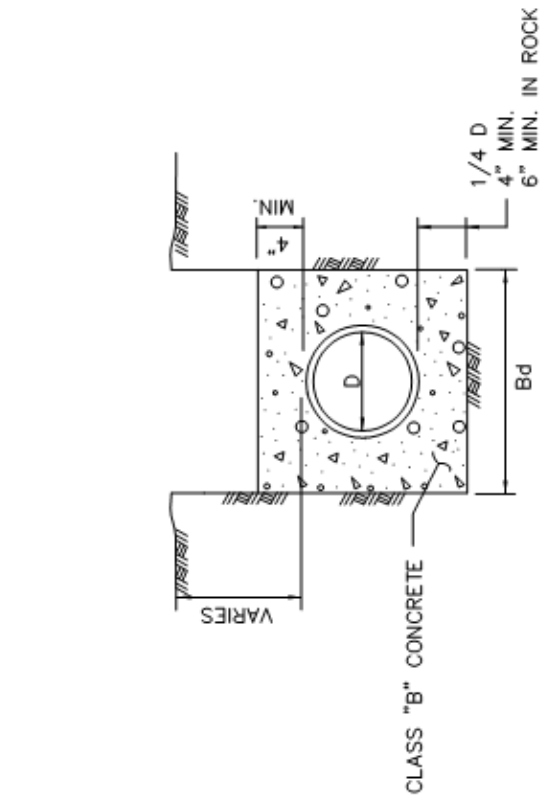
NOTES:

1. FOR MAINS 42" DIAMETER AND LARGER, 1/8 Bc SHALL BE TAKEN AS 6".
2. Bc = OUTSIDE DIAMETER OF PIPE
3. Bd = TRENCH WIDTH

CLASS "C" N.T.S.	CLASS "C+" N.T.S.	CLASS "C-1" N.T.S.
EMBEDMENT		
CITY OF ROCKWALL		
STANDARD SPECIFICATION REFERENCE 504.5		
STANDARD DRAWING NO. R-3040		
DATE Mar. 2018		
STANDARD DRAWING NO. R-3040		



CLASS "D+"  
N.T.S.



CLASS "G"  
N.T.S.

NOTES:

1. FOR MAINS 42" DIAMETER AND LARGER, 1/8 Bc SHALL BE TAKEN AS 6".
2. Bc = OUTSIDE DIAMETER OF PIPE
3. Bd = TRENCH WIDTH
4. D = INSIDE DIAMETER OF PIPE

STANDARD DRAWING NO.  
R-3050

CITY OF ROCKWALL



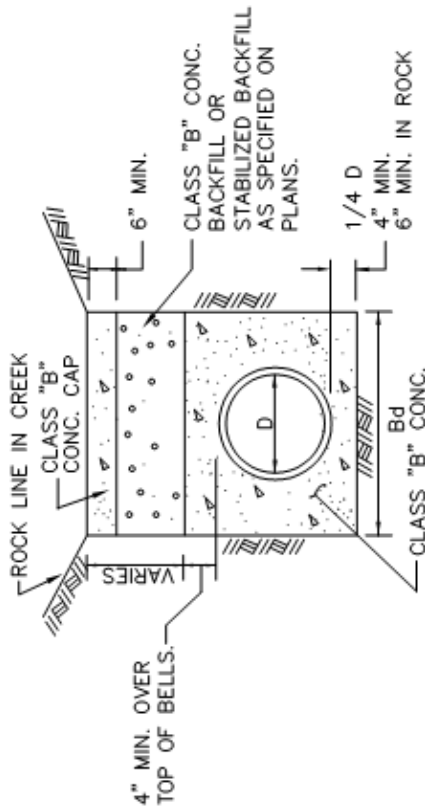
EMBEDMENT

CLASS "D+" & "G"

STANDARD SPECIFICATION REFERENCE  
504.5

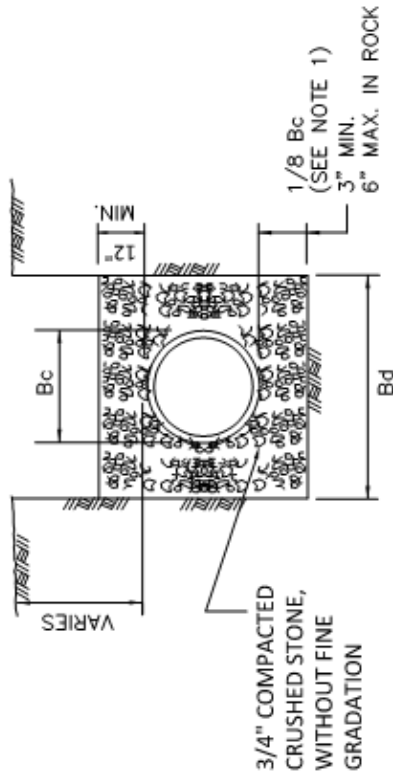
DATE  
Mar. 2018

STANDARD DRAWING NO.  
R-3050



**CLASS "G-1"**

(FOR ROCK DITCHES IN CREEKS)  
N.T.S.



**CLASS "H"**

N.T.S.

(TO BE USED FOR PVC WASTEWATER PIPE)

**NOTES:**

1. FOR MAINS 42" DIAMETER AND LARGER, 1/8 Bc SHALL BE TAKEN AS 6".
2. Bd = TRENCH WIDTH
3. Bc = OUTSIDE DIAMETER OF PIPE
4. D = INSIDE DIAMETER OF PIPE

STANDARD DRAWING NO.  
**R-3060**

**EMBEDMENT**  
**CLASS "G-1" & "H"**



**CITY OF ROCKWALL**

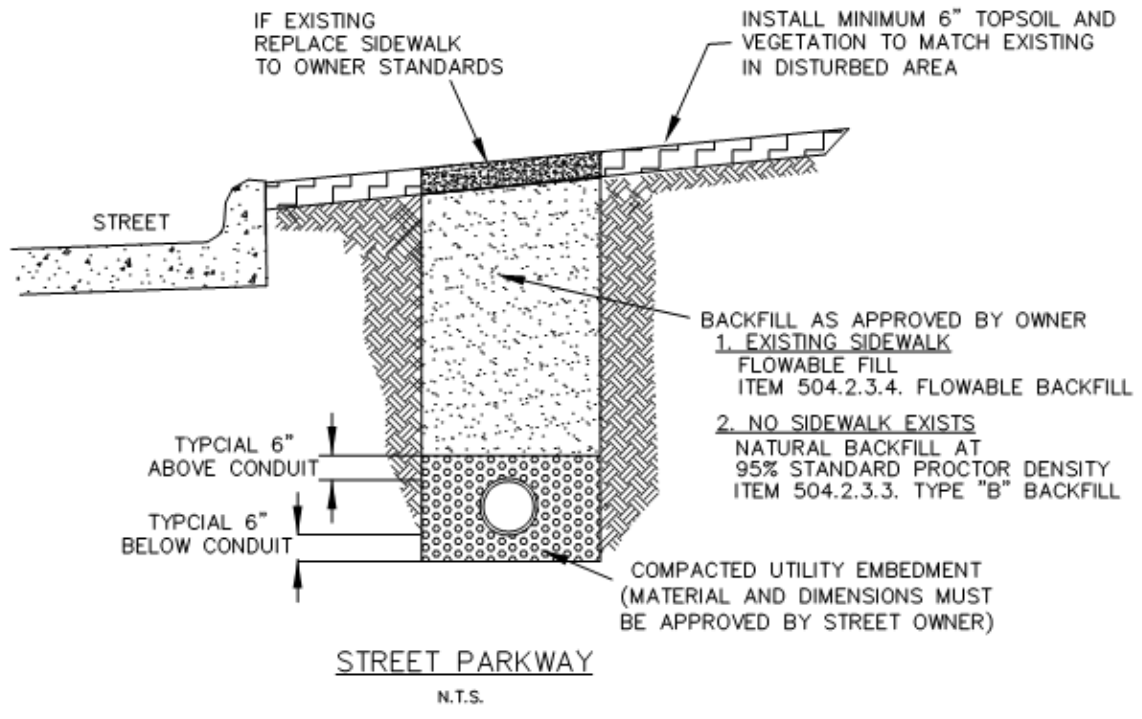
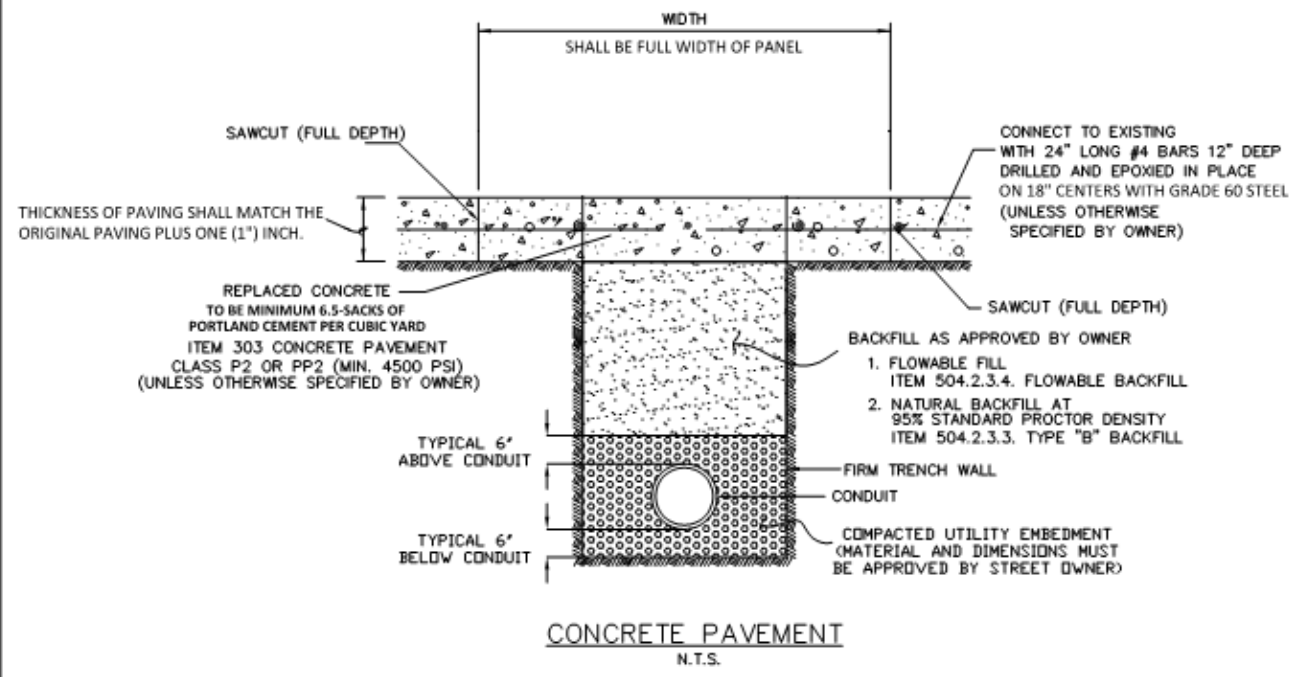
STANDARD SPECIFICATION REFERENCE  
**504.5**

DATE  
**AUG. '19**

STANDARD DRAWING NO.  
**R-3060**



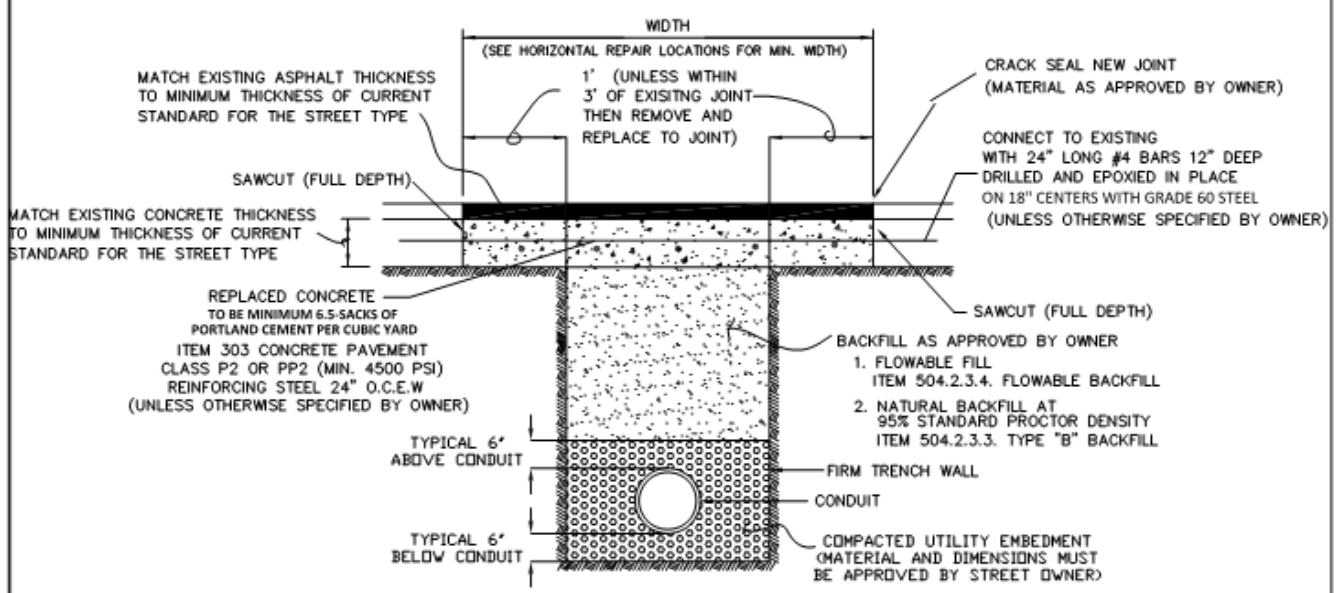
GENERAL NOTE: CHECK WITH STREET OWNER FOR SPECIFIC REQUIREMENTS NOT CONTAINED HEREIN



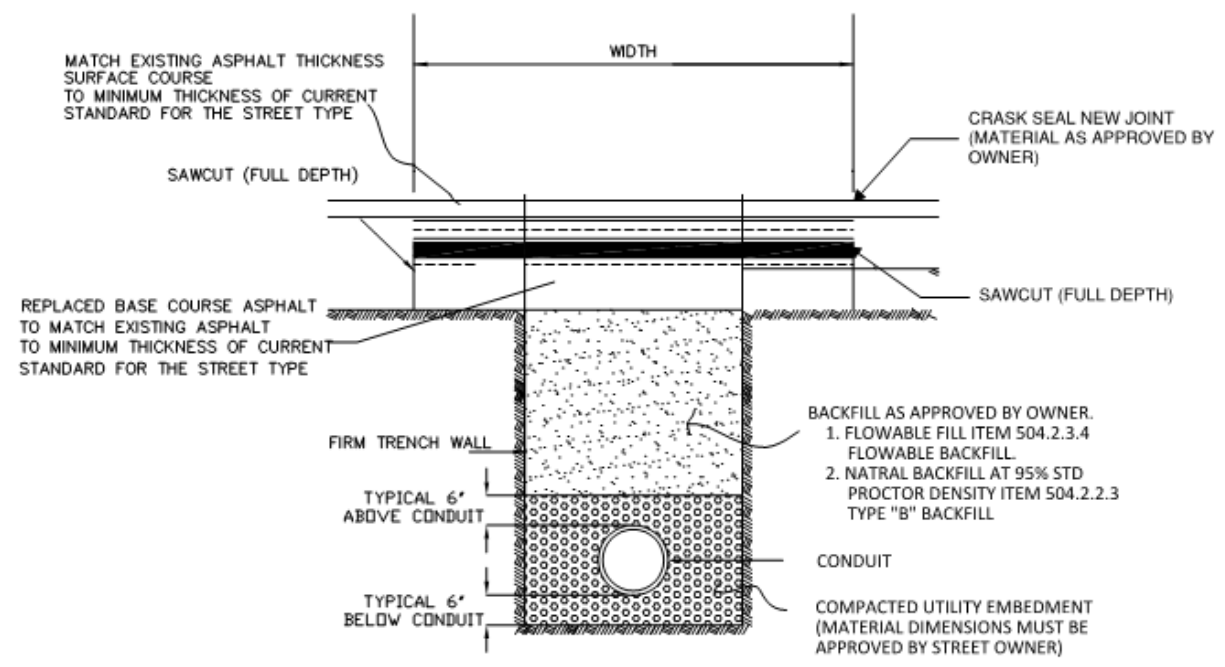
PAVEMENT CUT AND REPAIR CONCRETE AND PARKWAY	CITY OF ROCKWALL 	STANDARD SPECIFICATION REFERENCE 402	
		DATE Mar. 2018	STANDARD DRAWING NO. R-3070A



GENERAL NOTE: CHECK WITH STREET OWNER FOR SPECIFIC REQUIREMENTS NOT CONTAINED HEREIN

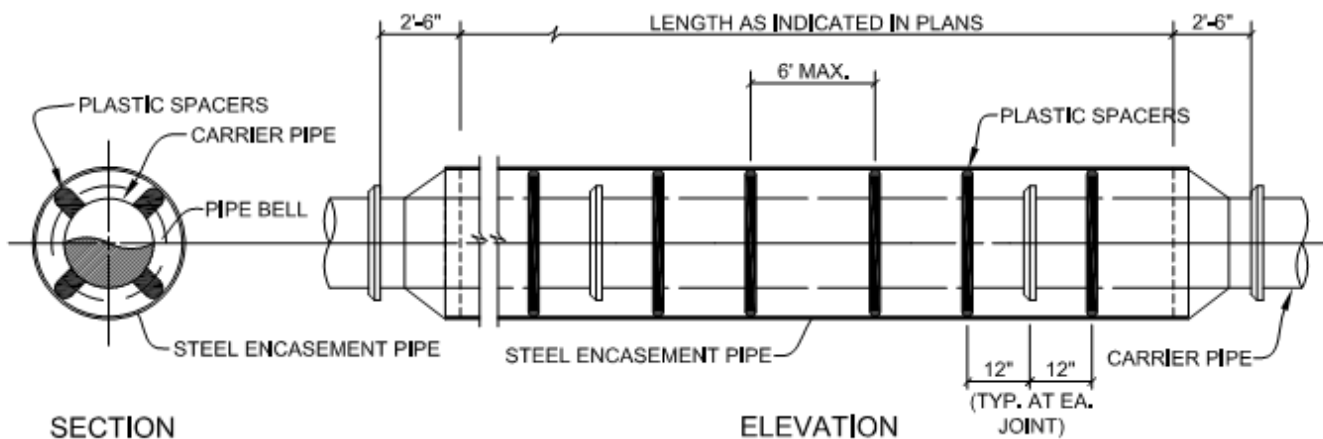


CONCRETE PAVEMENT WITH ASPHALT OVERLAY  
N.T.S.



FULL DEPTH ASPHALT PAVEMENT  
N.T.S.

PAVEMENT CUT AND REPAIR  ASPHALT	CITY OF ROCKWALL  	STANDARD SPECIFICATION REFERENCE 402	
		DATE Mar. 2018	STANDARD DRAWING NO. R-3070B



**ENCASED ROAD BORE**  
NO SCALE

**NOTES:**

- 1) ALL BORES BY CONTRACTOR SHALL BE DRY BORES.
- 2) PREFABRICATED PLASTIC SPACERS SHALL BE RACI NORTH AMERICA OR APPROVED EQUAL, FOR THE SPECIFIC APPLICATION AS RECOMMENDED BY THE MANUFACTURER.
- 3) CONTRACTOR SHALL PROVIDE SUPPORT UNDER CARRIER PIPE TO HAVE A MIN. 1" CLEARANCE BETWEEN PIPE BELL AND ENCASEMENT PIPE.
- 4) ENDS OF ENCASEMENT PIPE SHALL HAVE END SEALS INSTALLED PER MANUFACTURER'S REQUIREMENTS. END SEALS SHALL BE CCI MODEL ESW WRAP-AROUND BY CCI PIPELINE SYSTEMS OR APPROVED EQUAL.
- 5) THE DESIGN ENGINEER SHALL DESIGN THE MINIMUM THICKNESS OF THE ENCASEMENT PIPE. DESIGN WILL NEED TO INCLUDE DEAD LOADING BASED ON THE HEIGHT OF COVER AND HS-20 LOADINGS FOR ROADWAY CROSSINGS AND E-80 LOADINGS FOR RAILROAD CROSSINGS.
- 6) STEEL ENCASEMENT PIPE SHALL CONFORM TO AWWA C-200. PIPE SHALL BE FABRICATED IN ACCORDANCE WITH ASTM A-570 FROM STEEL PLATES HAVING MINIMUM YIELD STRENGTH 36,000 PSI.
- 7) STEEL ENCASEMENT PIPE SHALL BE PAINTED INSIDE AND OUTSIDE WITH TWO COATS OF TNEMEC, HB TNEMECOL, SERIES 46+465 COAL TAR, OR CITY APPROVED EQUIVALENT PRIOR TO DELIVERY TO THE JOB SITE. MINIMUM COATING INSIDE AND OUTSIDE SHALL BE 12+MILS DRY FILM THICKNESS (DFT) PER EACH COAT.
- 8) ENCASEMENT PIPE SHALL BE FIELD WELDED IN ACCORDANCE WITH AWWA C-206. WELDED JOINTS SHALL BE WIRE BRUSHED AND PAINTED WITH ONE COAT OF TNEMEC, OMNITHANE SERIES 530, 2.5-MILS DRY FILM THICKNESS (DFT) OR CITY APPROVED EQUIVALENT.

UNDERGROUND CONDUIT	CITY OF ROCKWALL		
STEEL ENCASED BORE		DATE OCT. '17	DRAWING NO. R-3090







## SECTION 8.04 | DIVISION 4000. WATER DISTRIBUTION

TABLE 8.4: REVISIONS TO NCTCOG'S DIVISION 4000 WATER DISTRIBUTION

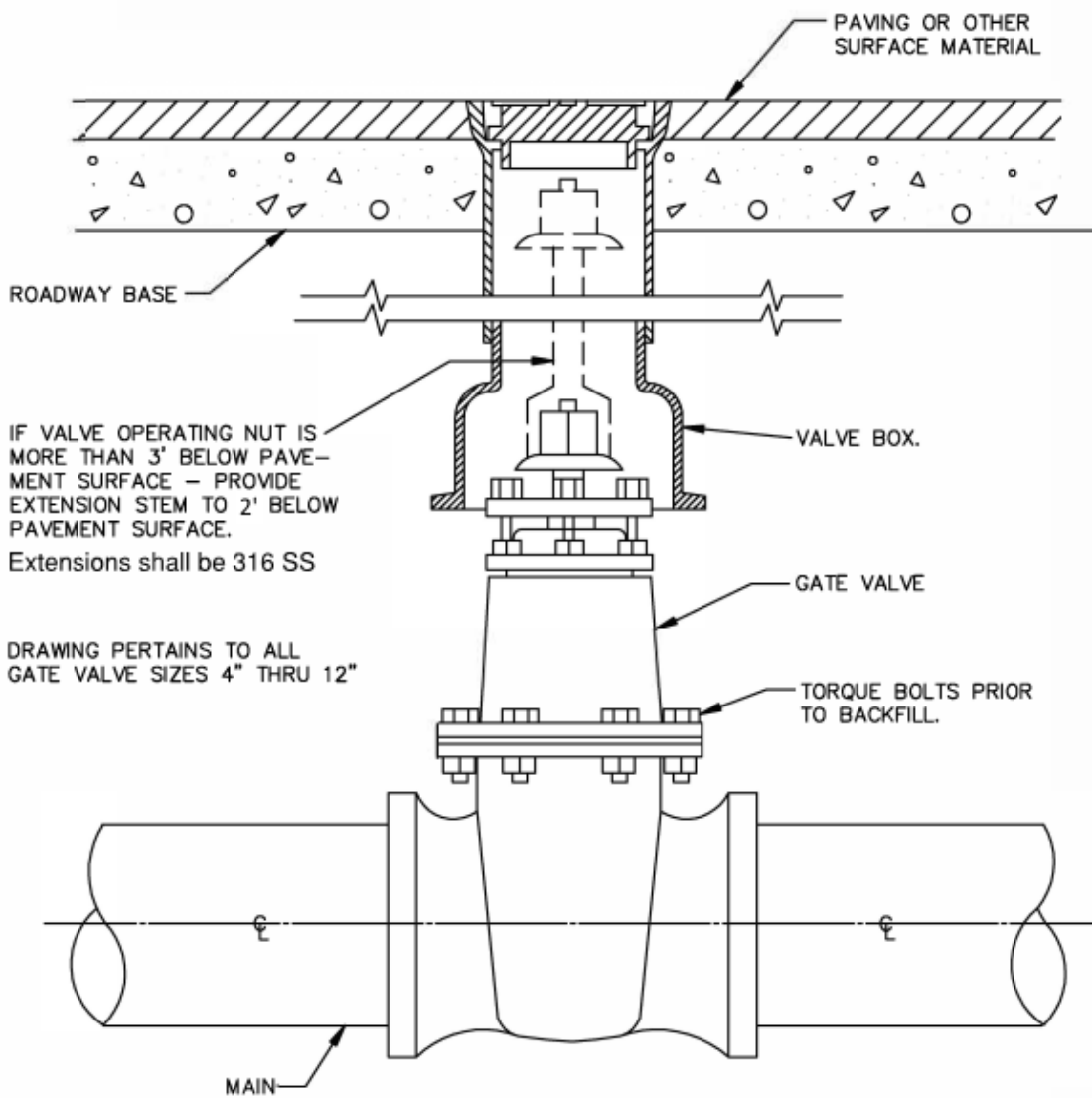
NOTES: (1) DELETED NCTCOG DRAWING; (2) REVISED NCTCOG DRAWING (SEE REVISIONS BELOW); (3) ADDED ROCKWALL STANDARD DRAWING (SEE DRAWING BELOW); AND (4) ADDED CURRENT TXDOT STANDARDS

REVISED	DRAWING NO.	DESCRIPTION
	4010A	HORIZONTAL THRUST BLOCKING – AT PIPE BEND
	4010B	HORIZONTAL THRUST BLOCKING – AT PIPE BEND
	4010C	HORIZONTAL THRUST BLOCKING – AT PIPE BEND
	4020	HORIZONTAL THRUST BLOCKING – AT TEES AND PLUGS
	4030	VERTICAL THRUST BLOCKING – AT PIPE BEND
	4040	THRUST BLOCK – GENERAL NOTES
(1)	4050	GATE VALVE 4" TO 12" – BOX & EXTENSION STEM
(3)	R-4050	GATE VALVE 4" TO 12" – BOX & EXTENSION STEM
(1)	4060A	VAULT CONSTRUCTION – HORIZONTAL GATE VALVE ≥ 16"
(1)	4060B	VAULT CONSTRUCTION – HORIZONTAL GATE VALVE ≥ 16"
(3)	R-4060	16" THRU 42" – HORIZONTAL BUTTERFLY VALVES
(1)	4070A	VAULT CONSTRUCTION – VERTICAL GATE VALVE ≥ 16"
(1)	4070B	VAULT CONSTRUCTION – VERTICAL GATE VALVE ≥ 16"
	4080A	VAULT CONSTRUCTION – BUTTERFLY VALVE ≥ 48"
	4080B	VAULT CONSTRUCTION – BUTTERFLY VALVE ≥ 48"
(1)	4090	COMBINATION AIR VACUUM VALVE – TYPE "1"
(3)	R-4090	COMBINATION AIR VACUUM VALVE – TYPE "1"
	4100A	COMBINATION AIR VACUUM VALVE – TYPE "2"
	4100B	AIR RELEASE VALVE – TYPE "2"
(1)	4110	FLUSH POINT INSTALLATION – TYPE "1"
(3)	R-4110	FLUSH POINT INSTALLATION – TYPE "1"
(1)	4120	FIRE HYDRANT - INSTALLATION
(3)	R-4120	FIRE HYDRANT - INSTALLATION
(1)	4130	WATER SERVICE INSTALLATION – ¾" OR 1" LINE
(3)	R-4130	WATER SERVICE INSTALLATION – 1" OR 1 ½" OR 2" LINE
(1)	4140	WATER SERVICE INSTALLATION – 1 ½" OR 2" LINE
(1)	R-4140	WATER SERVICE INSTALLATION – 1 ½" OR 2" LINE
(3)	R-4145	SINGLE SERVICE METER TAIL CONNECTION
(1)	4150	4" COMBINATION SERVICE – WITH 4" METER
(1)	R-4150	4" COMBINATION SERVICE – WITH 4" METER
(1)	4160	8" DETECTOR CHECK – SERVICE WITH 8" METER
(3)	R-4160	DOMESTIC METER VAULT – 3", 4" OR 6" LINE
(1)	4170	8" FIRE LINE STANDPIPE – SERVICE WITH 8" METER
(3)	R-4170	IRRIGATION METER VAULT – 3", 4" OR 6" LINE
(1)	4180	4" DOMESTIC SERVICE – WITH 3" METER
(1)	4190A	LARGE SERVICE METER – VAULT INSTALLATION
(1)	4190B	LARGE SERVICE METER – PRECAST VAULT
(1)	4200	WATER MAIN LOWERING – BELOW WASTEWATER MAIN
(3)	R-4200	WATER MAIN LOWERING – BELOW WASTEWATER MAIN




**NOTE:**

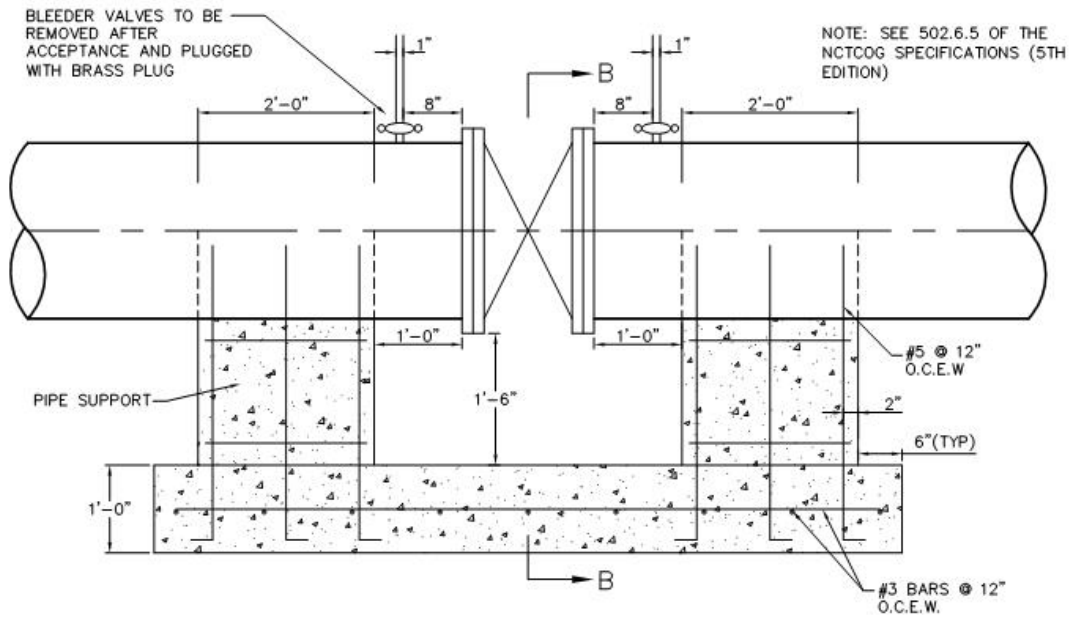
IN UNPAVED AREAS, INSTALL 2' x 2' x 6" CONCRETE VALVE PAD FLUSH WITH THE TOP OF VALVE BOX. REINFORCE WITH #3 BARS ON 6" CENTERS BOTH WAYS.



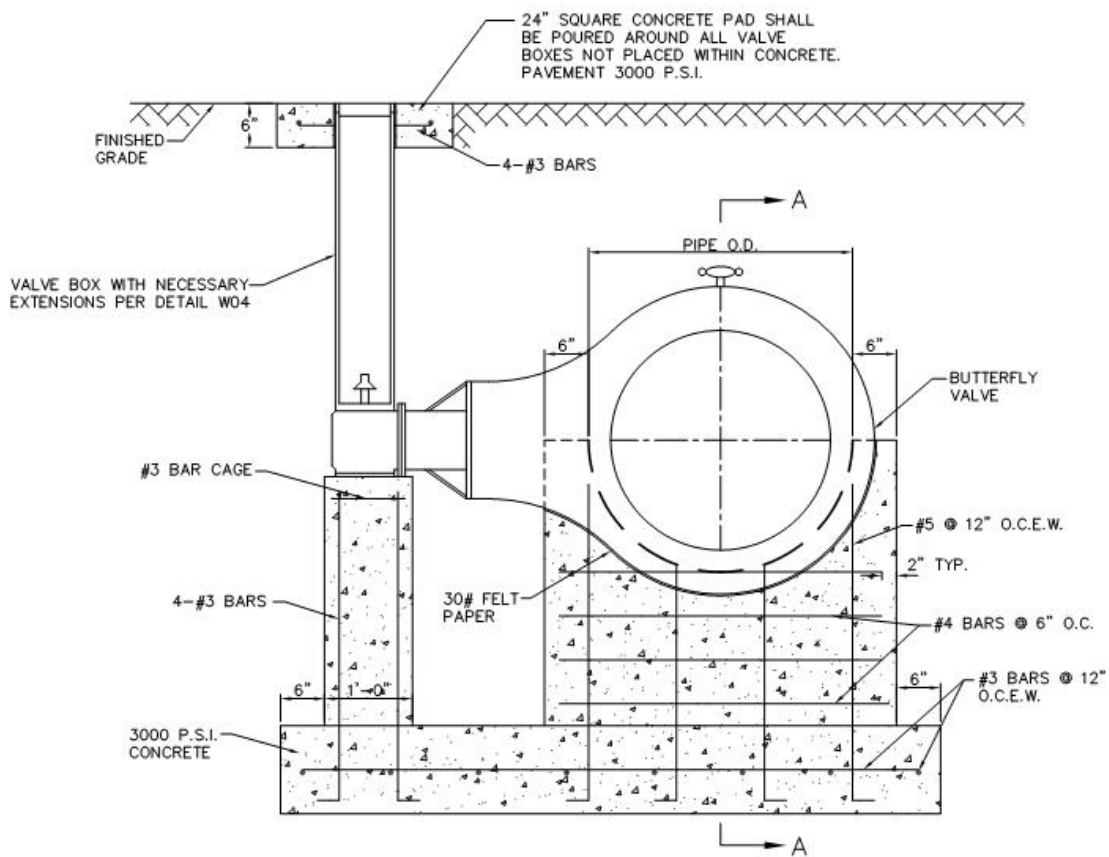
GATE VALVE BOX AND  
EXTENSION STEM

N.T.S.

GATE VALVE 4" TO 12"	CITY OF ROCKWALL	STANDARD SPECIFICATION REFERENCE 502.6.6*	
BOX & EXTENSION STEM		DATE AUG. '19	STANDARD DRAWING NO. R-4050

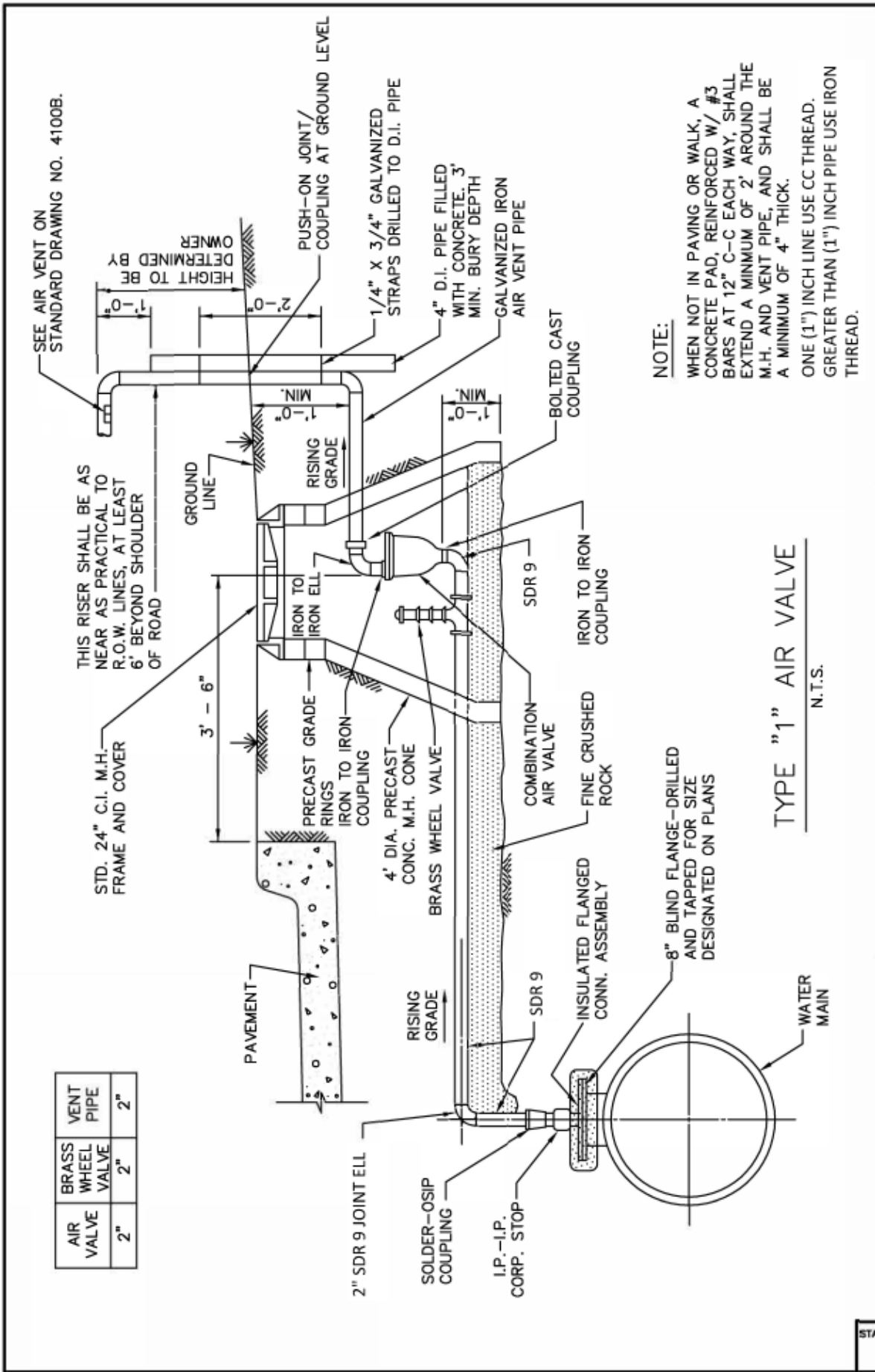


SECTION A-A



SECTION B-B

16" thru 42"	CITY OF ROCKWALL		
HORIZONTAL BUTTERFLY VALVES		DATE MAY 2022	DRAWING NO. R-4060



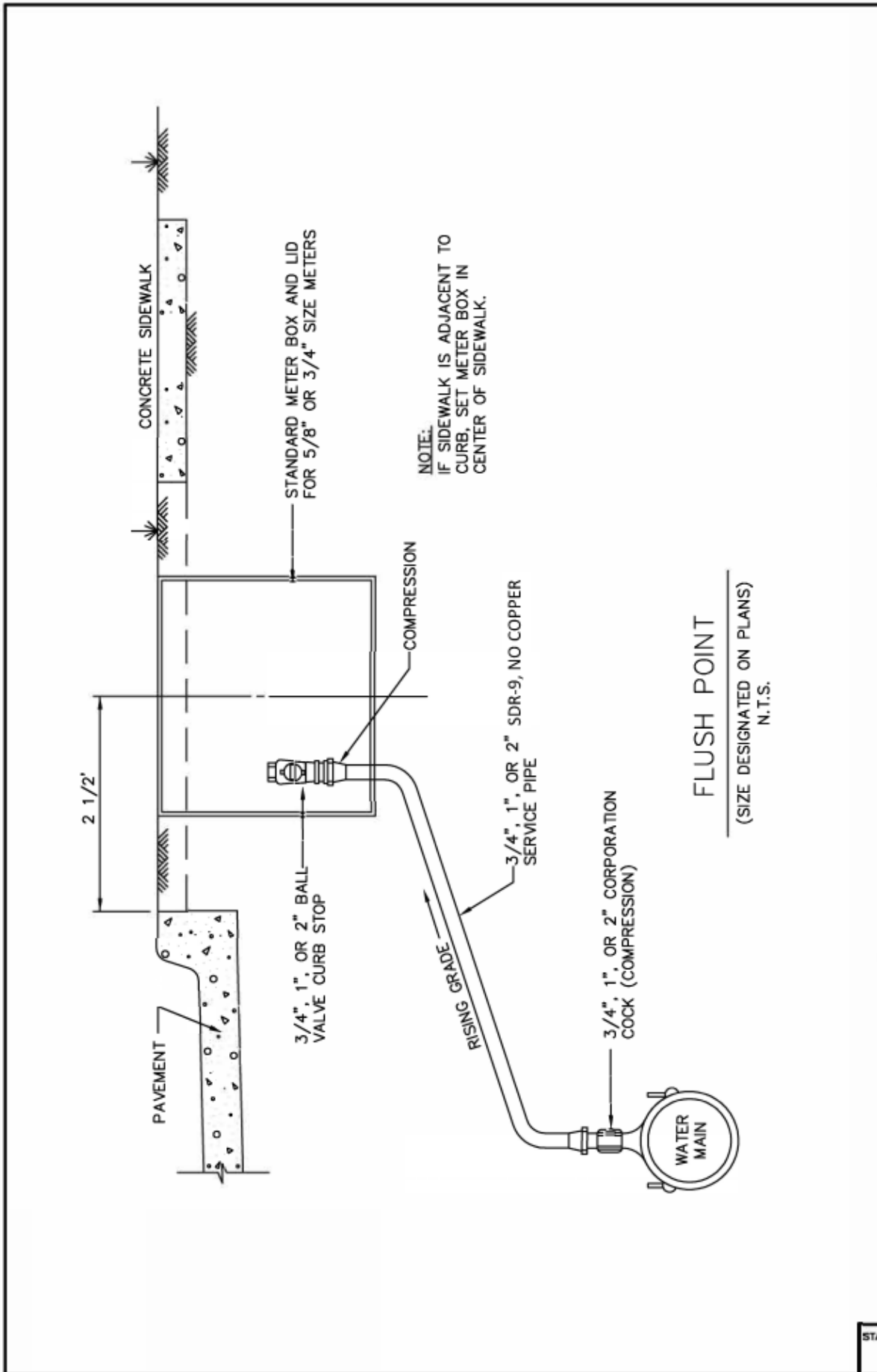
AIR VALVE	2"
BRASS WHEEL VALVE	2"
VENT PIPE	2"

**NOTE:**

WHEN NOT IN PAVING OR WALK, A CONCRETE PAD, REINFORCED W/ #3 BARS AT 12" C-C EACH WAY, SHALL EXTEND A MINIMUM OF 2' AROUND THE M.H. AND VENT PIPE, AND SHALL BE A MINIMUM OF 4" THICK.  
 ONE (1") INCH LINE USE CC THREAD.  
 GREATER THAN (1") INCH PIPE USE IRON THREAD.

TYPE "1" AIR VALVE  
 N.T.S.

COMBINATION AIR VACUUM VALVE TYPE "1"	CITY OF ROCKWALL 
STANDARD DRAWING NO. <b>R-4090</b>	STANDARD SPECIFICATION REFERENCE 502.6.6*
DATE Mar. 2018	STANDARD DRAWING NO. R-4090



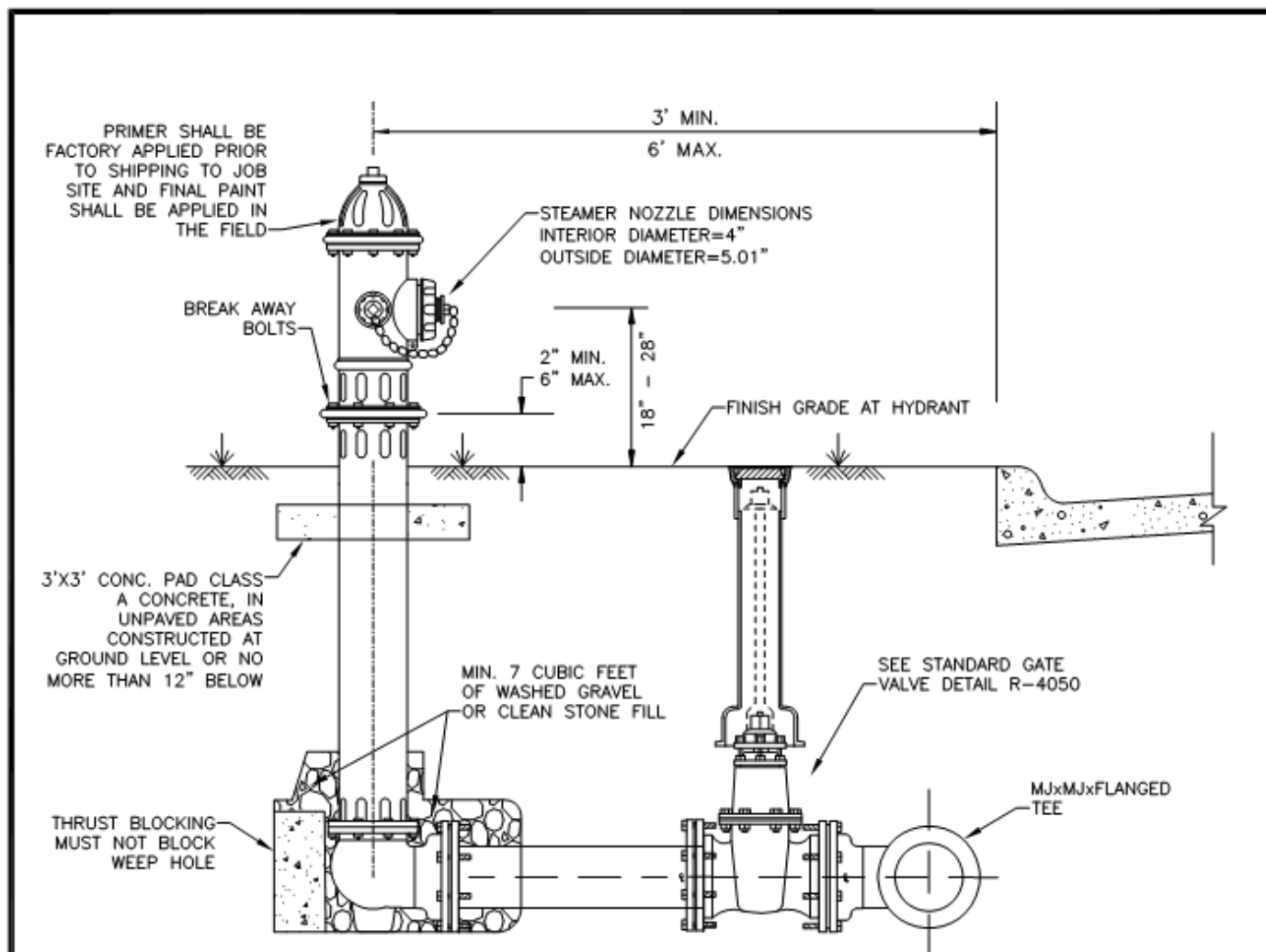
**FLUSH POINT**  
(SIZE DESIGNATED ON PLANS)  
N.T.S.

STANDARD SPECIFICATION REFERENCE	502.10.3*
DATE	Mar. 2018
STANDARD DRAWING NO.	R-4110



**FLUSH POINT INSTALLATION**  
CITY OF ROCKWALL  
TYPE "1"

STANDARD DRAWING NO.	R-4110
----------------------	--------



**NOTES:**

1. IN GENERAL, ALL FIRE HYDRANTS SHALL CONFORM TO AWWA STANDARD SPECIFICATIONS FOR FIRE HYDRANTS FOR ORDINARY WATER WORKS SERVICE, C-502. FIRE HYDRANTS SHALL HAVE A 5 $\frac{1}{4}$ " MIN. VALVE OPENING AND A BARREL APPROXIMATELY 7" INSIDE DIAMETER. ALL HYDRANTS SHALL BE EQUIPPED WITH BREAK AWAY FLANGE.
2. ALL JOINTS TO BE RESTRAINED JOINTS. MEGA-LUGS OR APPROVED EQUAL.
3. TYPICAL VALVE: ACTUAL VALVE LOCATION WILL DEPEND ON LOCATION OF WATER MAIN.
4. NO FIRE HYDRANT CLOSER THAN 18" TO EXISTING OR PROPOSED SIDEWALKS. (USUAL)
5. STANDARD BURY DEPTH 4 FEET.
6. SET FIRE HYDRANT ON THE LOT LINE EXTENDED WHEN POSSIBLE.

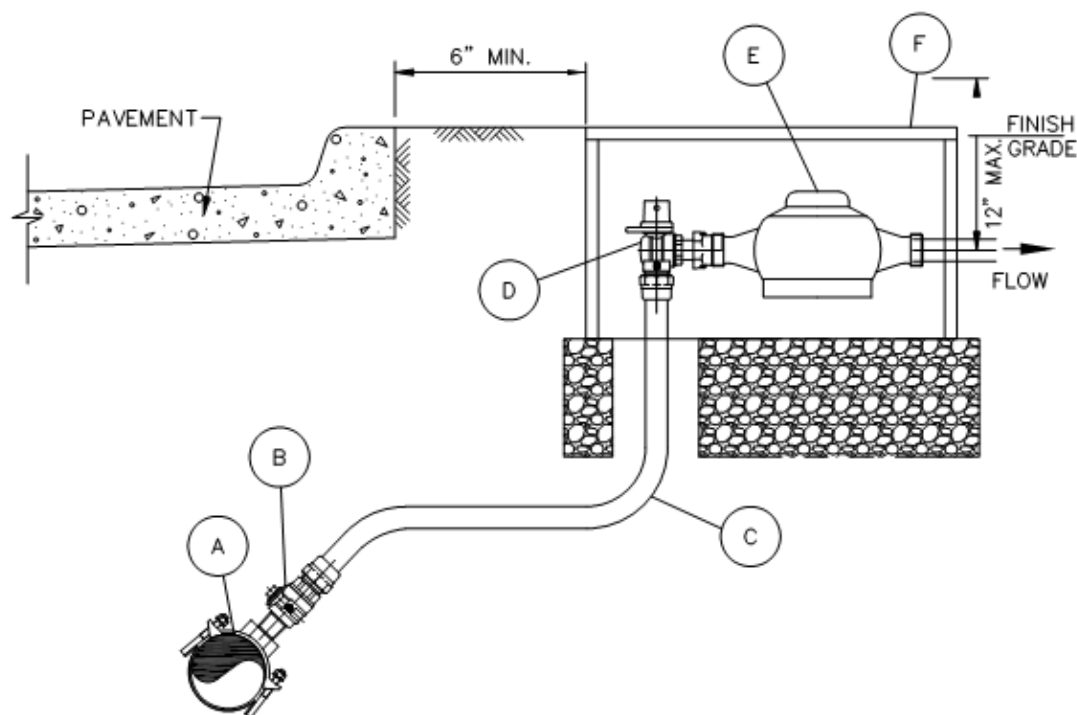
FIRE HYDRANT INSTALLATION

CITY OF ROCKWALL



DATE  
MAY '22

DRAWING NO.  
R-4120



## NOTES:

1. SERVICE PIPE SHALL BE 1" OR 2" SEAMLESS 250 PSI BLUE COLORED POLYETHYLENE ASTM D2737, SDR 9, CTS WATER SERVICE PIPE, NSF61 APPROVED.
2. TOP OF METER BOXES SHALL BE 1" ABOVE FINISHED GRADE.
3. METER BOX SHALL HAVE A MINIMUM OF 6" OF GRAVEL BENEATH METER BOX AS ILLUSTRATED.
4. LOCATION OF THE METER BOX SHALL BE LOCATED TO ALLOW 6" CLEARANCE FROM CURB.

## MATERIAL LIST:

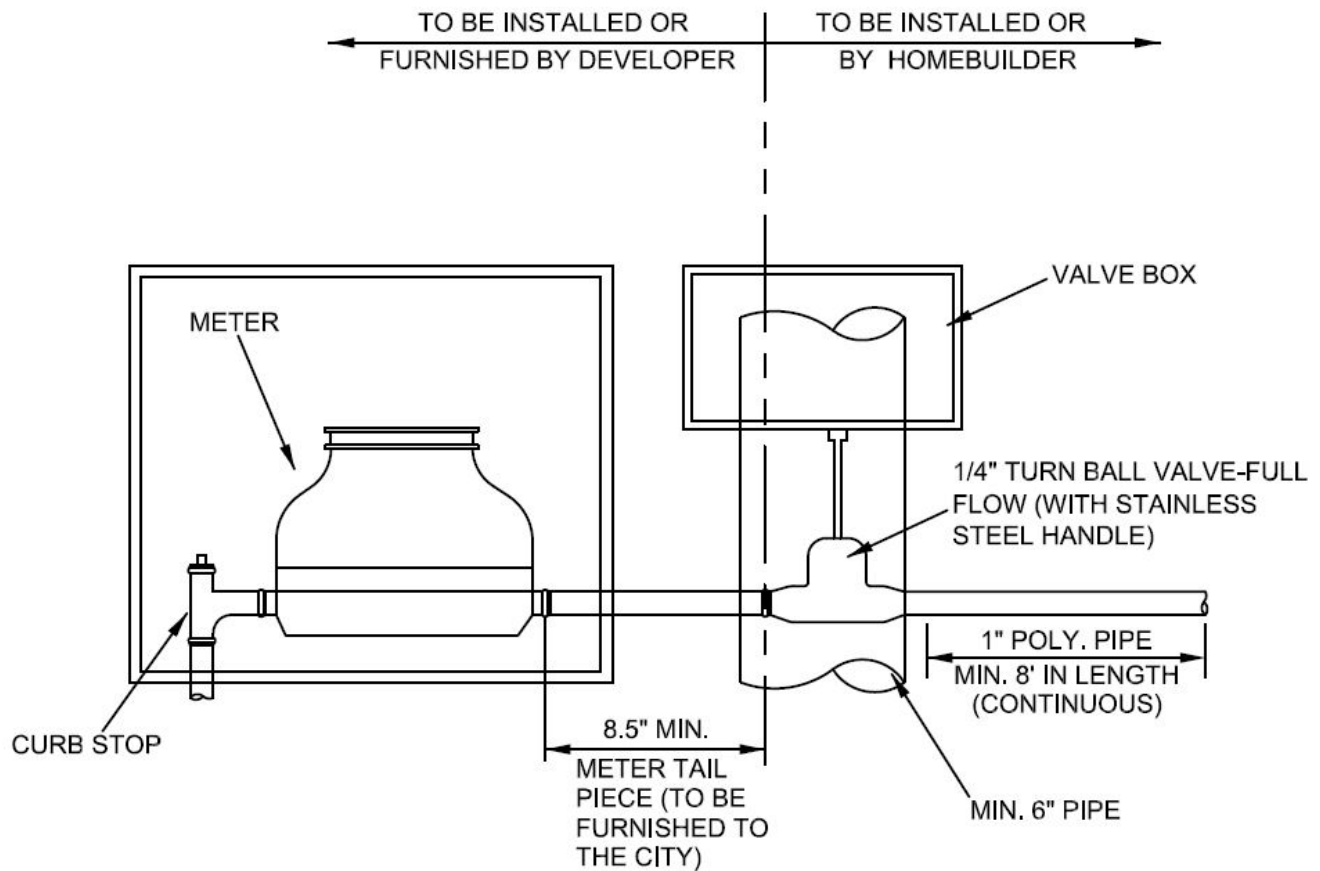
- A. SERVICE SADDLE SHALL BE BRASS WITH DOUBLE BRONZE FLATTENED STRAPS OR STAINLESS STEEL DOUBLE BOLT WIDE STRAPS. NO BANDED OR HINGED STRAPS SHALL BE ALLOWED. SERVICE SADDLES SHALL MEET AWWA/CC TAPPING OUTLET (TAPERED THREADS) REQUIREMENTS. ALL SERVICE SADDLES SHALL BE PER APPROVED WATER MATERIALS LIST.
- B. 1" OR 2" CORPORATION STOP PER APPROVED WATER MATERIALS LIST.
- C. 1" OR 2" SERVICE PIPE SHALL BE SEAMLESS 250 PSI BLUE COLORED POLYETHYLENE ASTM D2737, SDR9, CTS WATER SERVICE PIPE, NSF61 APPROVED.
- D. 1" OR 2" LOCKING ANGLE METER VALVE (STOP) PER APPROVED WATER MATERIALS LIST.
- E. WATER METERS CENTERED IN BOX AS ILLUSTRATED.
- F. ROUND METER BOX PER APPROVED WATER MATERIALS LIST.

WATER SERVICE INSTALLATION

CITY OF ROCKWALL

1" OR 2" LINE


DATE  
AUG '19DRAWING NO.  
R-4130



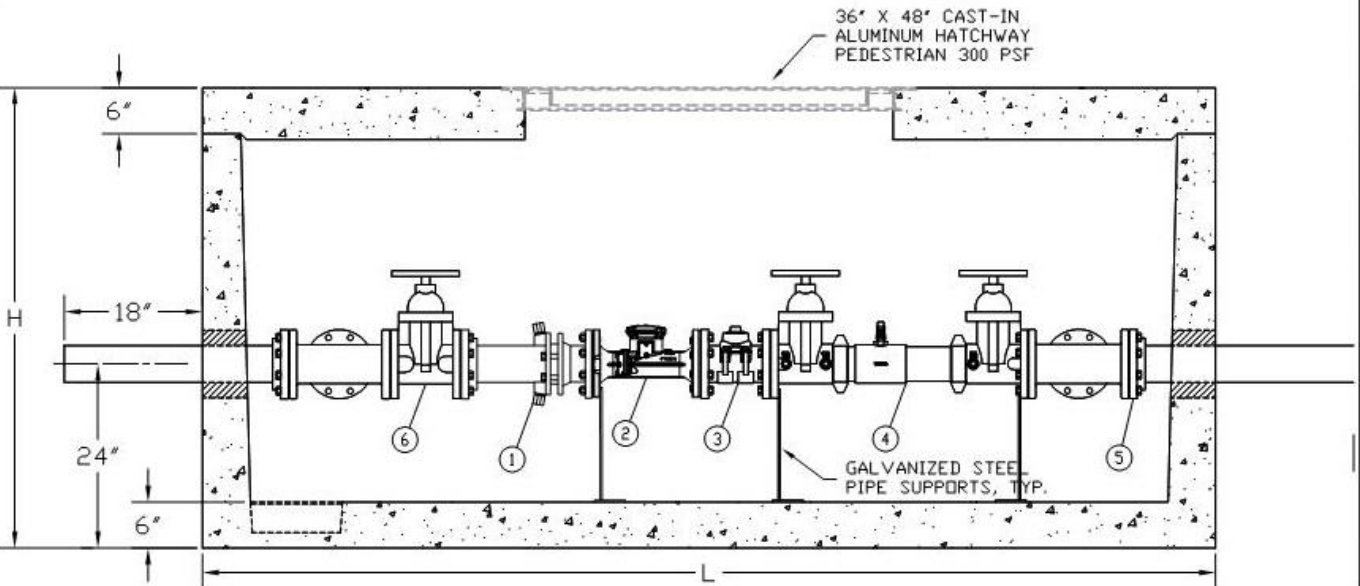
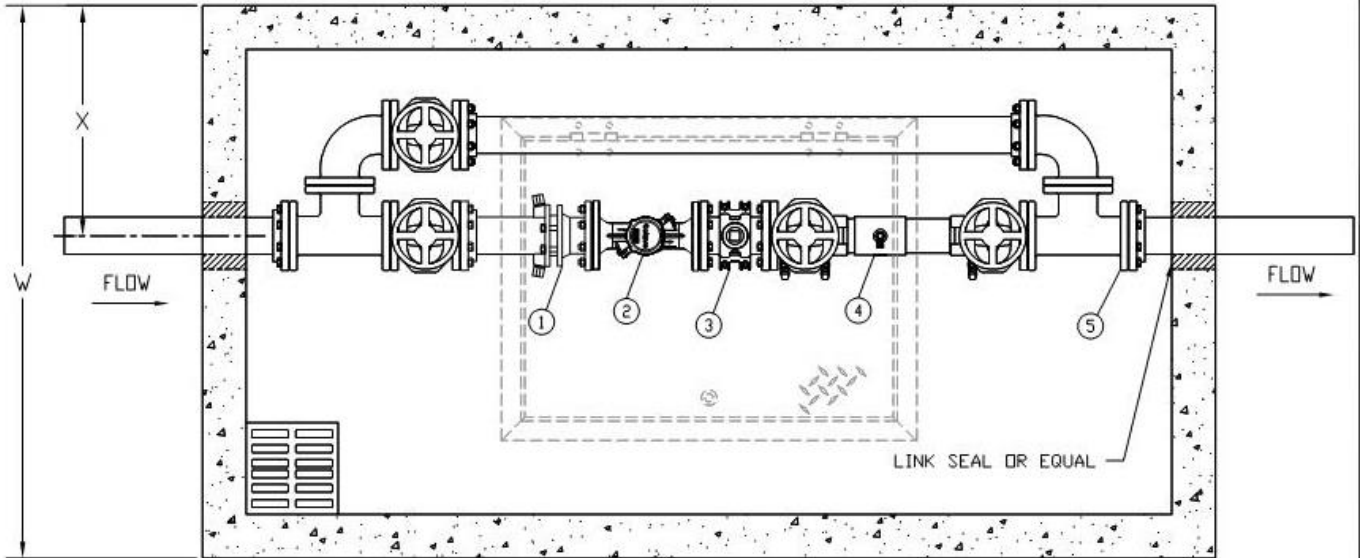
NOTE:

VALVE BOX TO BE TRAFFIC RATED IF UNDER PAVING.

**SINGLE SERVICE METER TAIL CONNECTION**  
NOT TO SCALE

<p>WATER METER DETAIL</p>	<p>CITY OF ROCKWALL</p>		
<p>SINGLE SERVICE</p>		<p>DATE AUG. '15</p>	<p>DRAWING NO. R-4145</p>





SIZE	L	W	H
3"	11'- 0"	6'- 0"	5'- 0"
4"	8'- 8"	5'- 0"	5'- 0"
6"	11'- 0"	6' 0"	5'- 0"

NOTES:

1. CONCRETE SHALL HAVE MIN STRENGTH OF 4200 PSI AT 28 DAYS. NO CAST IN PLACE VAULTS SHALL BE ALLOWED.
2. REINFORCEMENT SHALL BE GRADE 60. STEEL BAR SHALL CONFORM TO ASTM A615 ON REQUIRED CENTERS OR EQUALS.
3. ACCESS IS 1/4" ALUMINUM DIAMOND PLATE COVER WITH ALUMINUM FRAME. HATCH TO BE FURNISHED WITH 316 STAINLESS STEEL SLAM LOCK & HINGES.

ITEM	DESCRIPTION
1	FLANGE COUPLING ADAPTER
2	MASTER METER OCTAVE METER
3	STRAPPING SADDLE W/2" NPT PLUG
4	DOUBLE CHECK ASSEMBLY
5	FLG X P.E. SPOOL, D.I.
6	FLG NRS GATE VALVE

DOMESTIC WATER METER VAULT

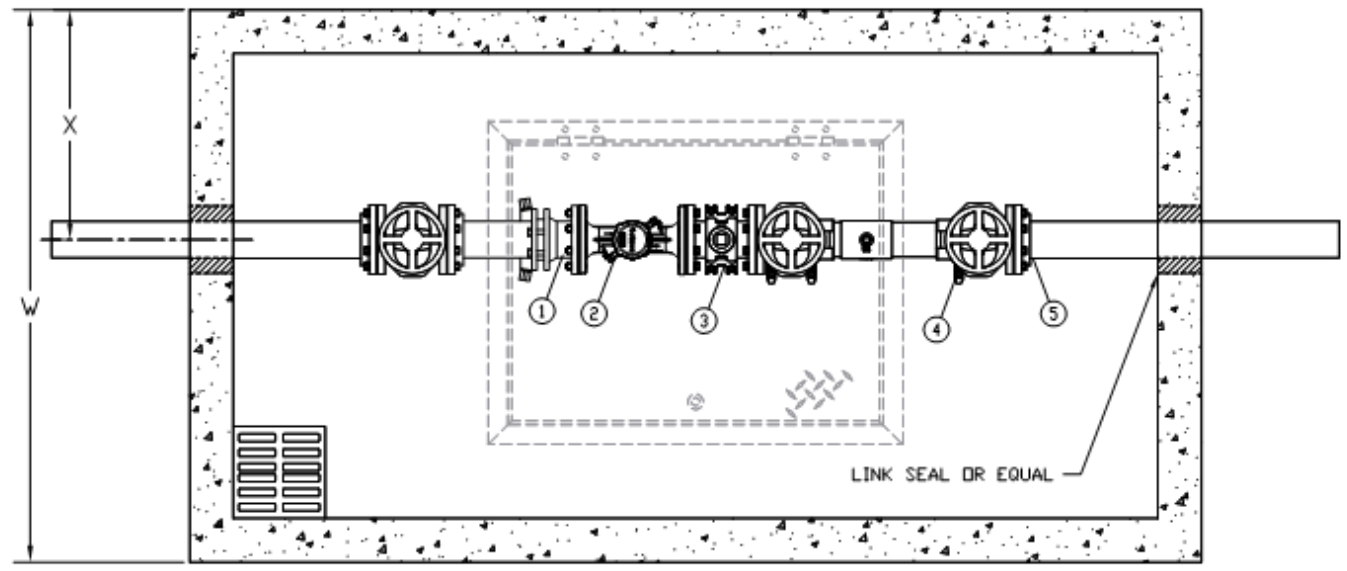
CITY OF ROCKWALL

3", 4" OR 6" LINE

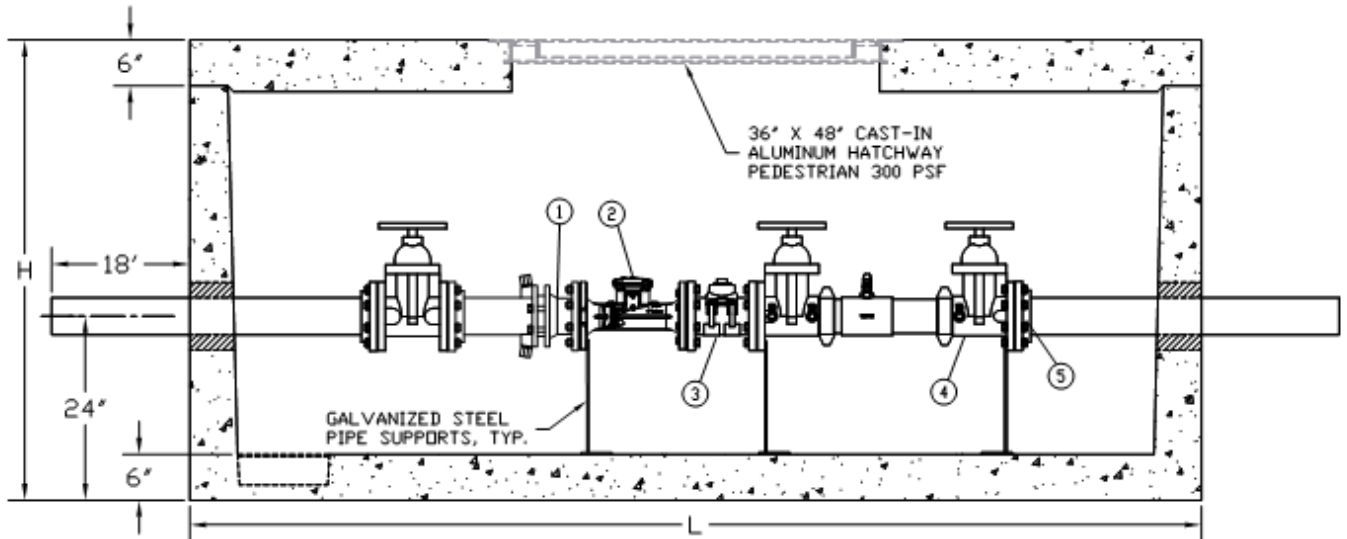


DATE  
AUG '19

DRAWING NO.  
R-4160



PLAN VIEW



ELEVATION VIEW

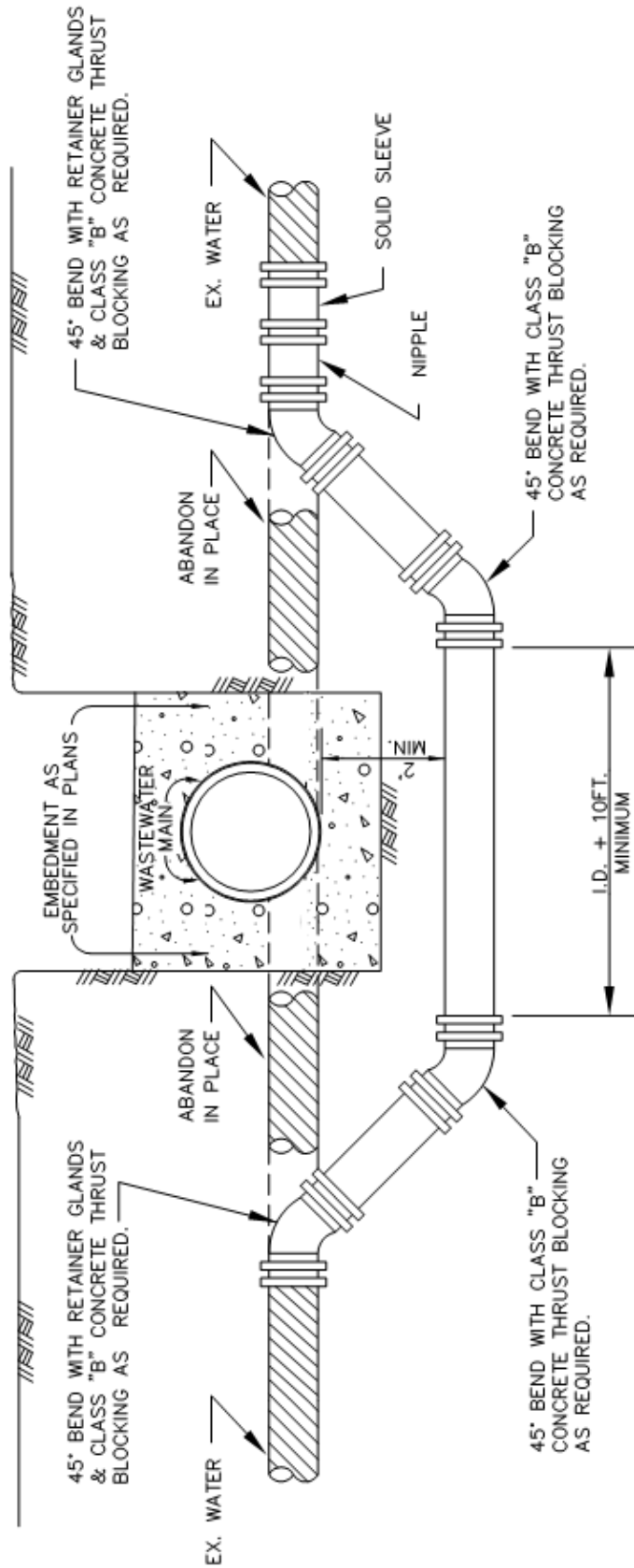
SIZE	L	W	H
3"	11'- 0"	6'- 0"	5'- 0"
4"	11'- 0"	6'- 0"	5'- 0"
6"	11'- 0"	6'- 0"	5'- 0"

NOTES:

1. CONCRETE SHALL HAVE MIN STRENGTH OF 4200 PSI AT 28 DAYS. NO CAST IN PLACE VAULTS SHALL BE ALLOWED.
2. REINFORCEMENT SHALL BE GRADE 60. STEEL BAR SHALL CONFORM TO ASTM A615 ON REQUIRED CENTERS OR EQUALS.
3. ACCESS IS 1/4" ALUMINUM DIAMOND PLATE COVER WITH ALUMINUM FRAME. HATCH TO BE FURNISHED WITH 316 STAINLESS STEEL SLAM LOCK & HINGES.

ITEM	DESCRIPTION
1	FLANGE COUPLING ADAPTER
2	MASTER METER OCTAVE METER
3	STRAPPING SADDLE W/2" NPT PLUG
4	DOUBLE CHECK ASSEMBLY
5	FLG X P.E. SPOOL, D.I.

IRRIGATION WATER METER VAULT	CITY OF ROCKWALL		
3", 4" OR 6" LINE		DATE AUG '19	DRAWING NO. R-4170



CONCRETE ENCASEMENT SHALL ENCASE ENTIRE WASTEWATER MAIN. DEFLECT WATER LINE WHEN POSSIBLE.

STANDARD SPECIFICATION REFERENCE	506.6
DATE	Mar. 2018
STANDARD DRAWING NO	R-4200

CITY OF ROCKWALL

WATER MAIN LOWERING  
BELOW WASTEWATER MAIN

STANDARD DRAWING NO	R-4200
---------------------	--------



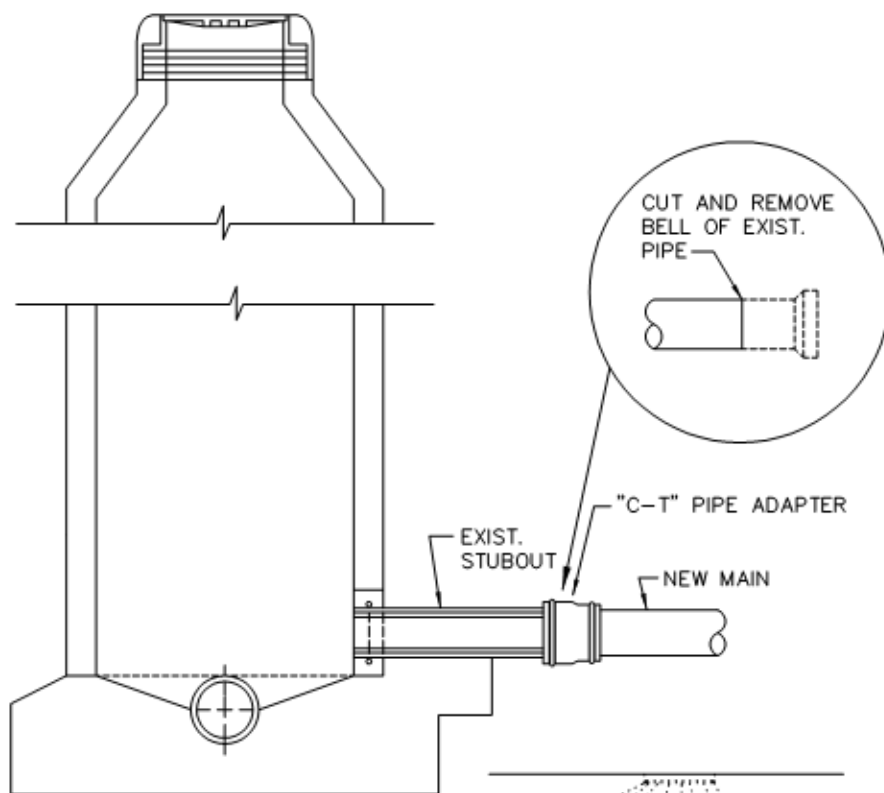


## SECTION 8.05 | DIVISION 5000. WASTEWATER COLLECTION

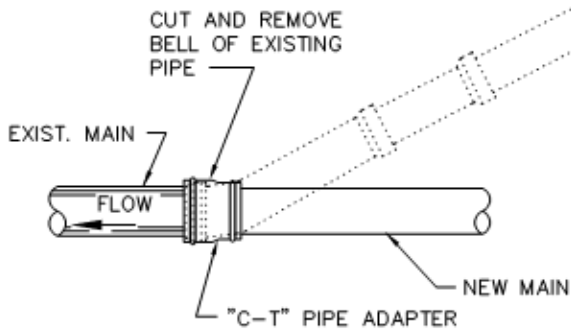
### TABLE 8.5: REVISIONS TO NCTCOG'S DIVISION 5000 WASTEWATER COLLECTION

NOTES: (1) DELETED NCTCOG DRAWING; (2) REVISED NCTCOG DRAWING (SEE REVISIONS BELOW); (3) ADDED ROCKWALL STANDARD DRAWING (SEE DRAWING BELOW); AND (4) ADDED CURRENT TXDOT STANDARDS

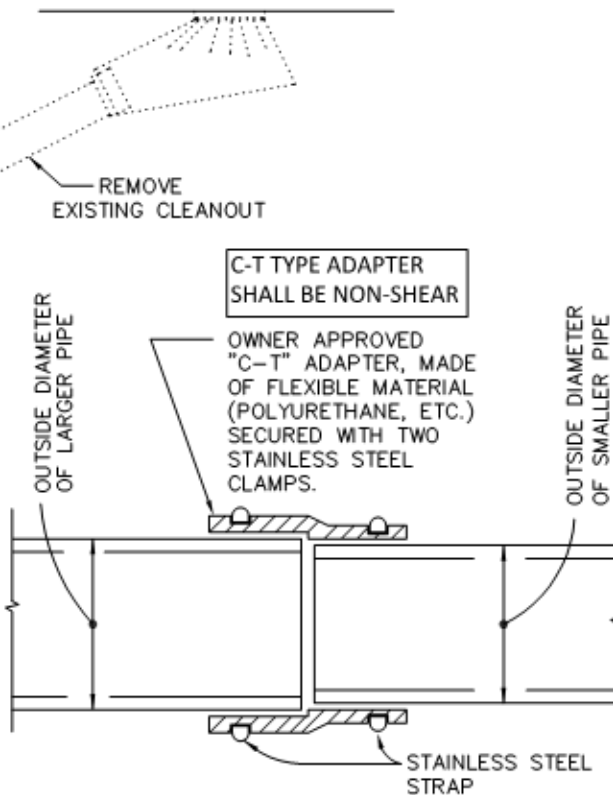
REVISED	DRAWING NO.	DESCRIPTION
(1)	5010	WASTEWATER MAIN TIE-IN – AT CLEANOUT OR M.H. STUBOUT
(3)	R-5010	WASTEWATER MAIN TIE-IN – AT CLEANOUT OR M.H. STUBOUT
(1)	5020	WASTEWATER MANHOLE – PRECAST
(3)	R-5020	WASTEWATER MANHOLE – PRECAST
(1)	5030	WASTEWATER MANHOLE – CAST-IN-PLACE
(3)	R-5030	WASTEWATER MANHOLE – CAST-IN-PLACE
(3)	R-5031	WASTEWATER MANHOLE – INFLOW PREVENTION & CORROSION PROTECTION
(1)	5040	WASTEWATER MANHOLE – FIBERGLASS
(1)	5050	WASTEWATER MANHOLE – PRESSURE TYPE
(3)	R-5050	WASTEWATER MANHOLE – PRESSURE TYPE
(1)	5060	WASTEWATER MANHOLE – VENTED
(3)	R-5060	WASTEWATER MANHOLE – VENTED
(1)	5070	WASTEWATER MANHOLE – OUTSIDE DROP CONNECTIONS
(1)	5080	WASTEWATER MANHOLE – INSIDE DROP CONNECTION
(3)	R-5080	WASTEWATER MANHOLE – INSIDE DROP CONNECTION
	5090	WASTEWATER MANHOLE – LINE INTERSECTION
	5100	WASTEWATER MANHOLE – FALSE BOTTOM
(3)	R-5101	WASTEWATER MANHOLE – HINGED RIM & COVER
(3)	R-5102	WASTEWATER MANHOLE – BOLT AND GASKET RIM & COVER
(3)	R-5103	WASTEWATER MANHOLE – PRIVATE RIM & COVER
(1)	5110	WASTEWATER MAIN – CLEANOUT
(3)	R-5110	WASTEWATER MAIN – CLEANOUT
(1)	5120	WASTEWATER LATERALS – WITH & WITHOUT CLEANOUT
(3)	R-5120	WASTEWATER LATERAL CONNECTIONS – RESIDENTIAL
(1)	5130	WASTEWATER LATERAL CONNECTIONS – IN EARTH & IN ROCK
	5140	WASTEWATER LATERAL CONNECTIONS – CLEANOUT FRAME & COVER
(1)	5150	WASTEWATER LATERAL STUBOUT – IN ADVANCE OF PAVING
(3)	R-5150	WASTEWATER LATERAL STUBOUT – IN ADVANCE OF PAVING
(1)	5160	WASTEWATER LATERAL REPLACEMENT – IN ADVANCE OF PAVING
(3)	R-5160	WASTEWATER LATERAL REPLACEMENT – IN ADVANCE OF PAVING
(1)	5170	ABANDONMENT OF MANHOLE – IN OR OUT OF PAVEMENT
(3)	R-5170	ABANDONMENT OF MANHOLE – IN OR OUT OF PAVEMENT
(3)	R-5180	MANHOLE AND VALVE VAULT – MOW STRIP



**AT STUBOUT**  
N.T.S.



**AT CLEANOUT**  
N.T.S.



**"C-T" PIPE ADAPTER**  
N.T.S.

**NOTE:**  
THIS DETAIL FOR USE ONLY WHEN NEW MAIN WILL NOT MATE WITH EXISTING MAIN JOINT DUE TO DIFFERENT DIMENSIONS OR MATERIALS AND A MANHOLE IS NOT REQUIRED.

WASTEWATER MAIN TIE-IN  
AT CLEANOUT OR M.H. STUBOUT



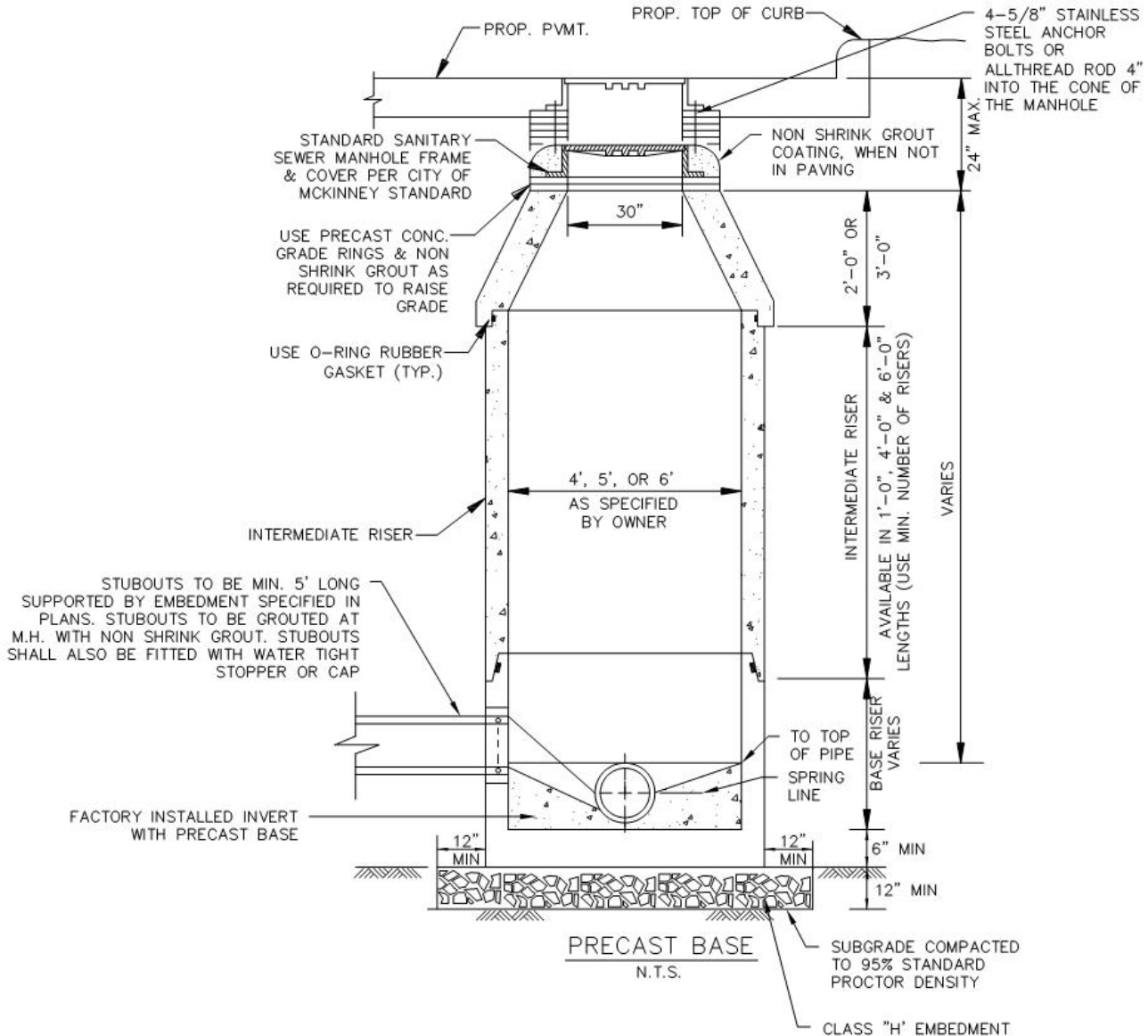
STANDARD SPECIFICATION REFERENCE  
502.10

DATE: Mar. 2018  
STANDARD DRAWING NO.: R-5010



NOTES:

1. FIRST MAIN LINE JOINT TO BE A MIN. OF 5' LONG.
2. IF FALSE M.H. ARE REQUIRED, THEY SHALL BE CONSTRUCTED, INSTALLED AND REMOVED PER STD. DWG. NO. 5100.
3. M.H.'S LOCATED OUTSIDE OF PAVING SHALL BE CONSTRUCTED WITH A CONCRETE MOW STRIP PER STD. DWG. NO. R-7005.
4. REFER TO STD. DWG. NO. R-5031 FOR INFLOW PROTECTION AT MANHOLE GRADE RINGS, MANHOLE JOINTS AND ON OUTSIDE OF STRUCTURE.
5. REFER TO STD. DWG. NO. R-5032 FOR CORROSION PROTECTION.
6. CONCRETE SHALL BE 4,200 PSI (7.0 SACK/CY) 28 DAY STRENGTH.
7. REINFORCING SHALL MEET OR EXCEED ASTM C478 REQUIREMENTS.
8. INSTALL GREEN EMS DISK AT ALL MANHOLES.
9. LIP TO BE PRECAST.
10. INSTALL A MINIMUM OF FOUR (4) 5/8" STAINLESS STEEL ANCHOR BOLTS OR ALLTHREAD ROD 4" INTO THE CONE OF THE MANHOLE TO HOLD THE RING AND COVER. ALLTHREAD MUST BE EPOXIED IN PLACE.



WASTEWATER MANHOLE

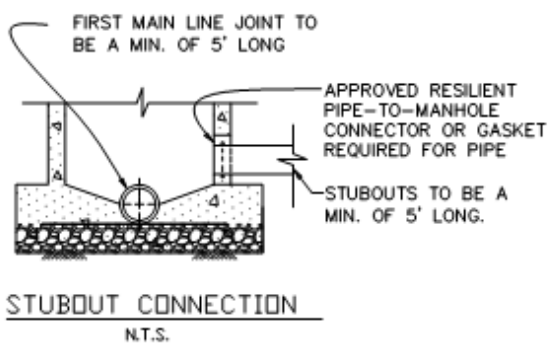
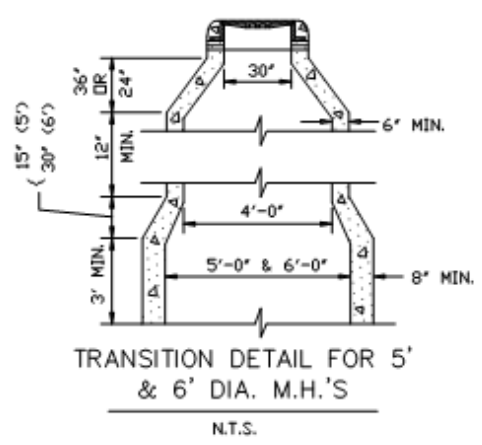
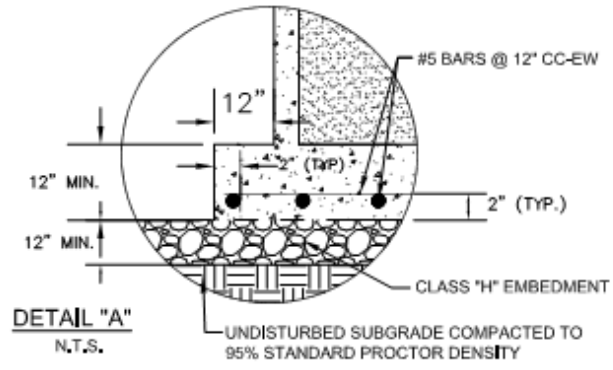
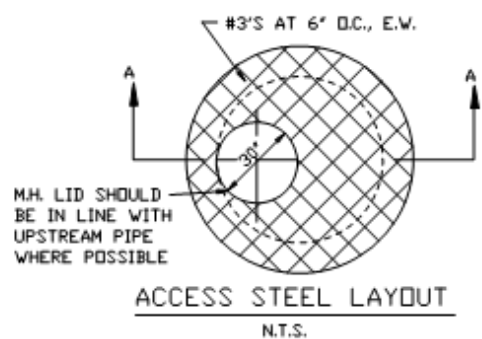
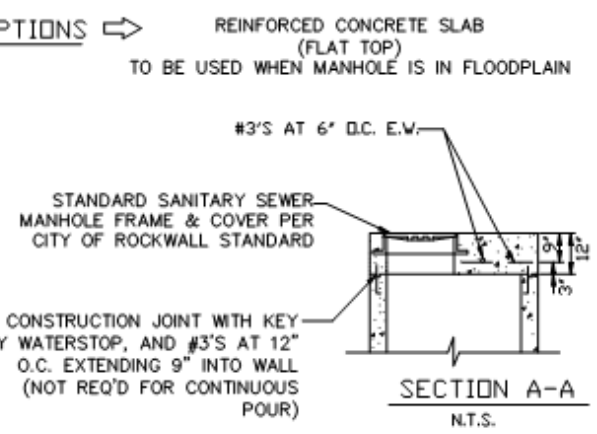
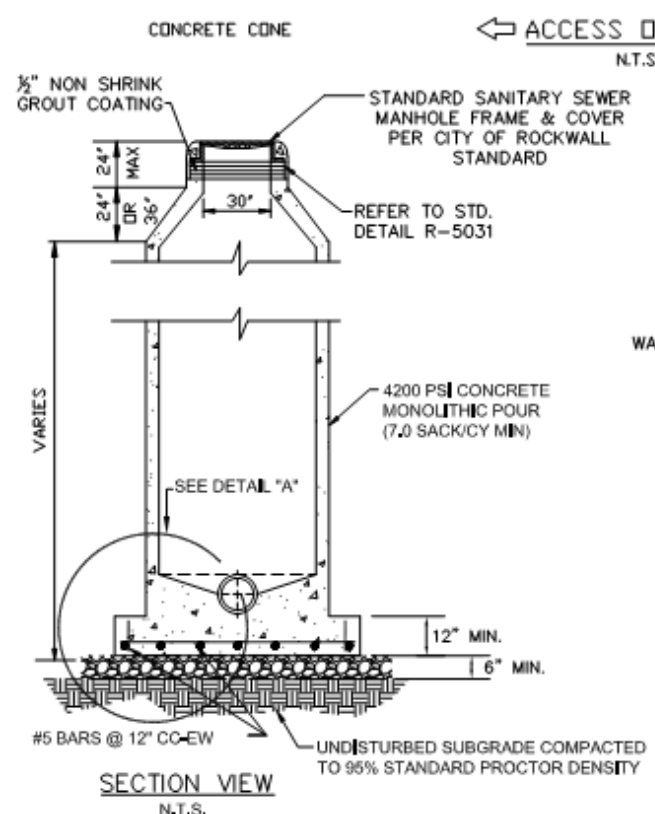
CITY OF ROCKWALL

PRECAST



DATE  
DEC '22

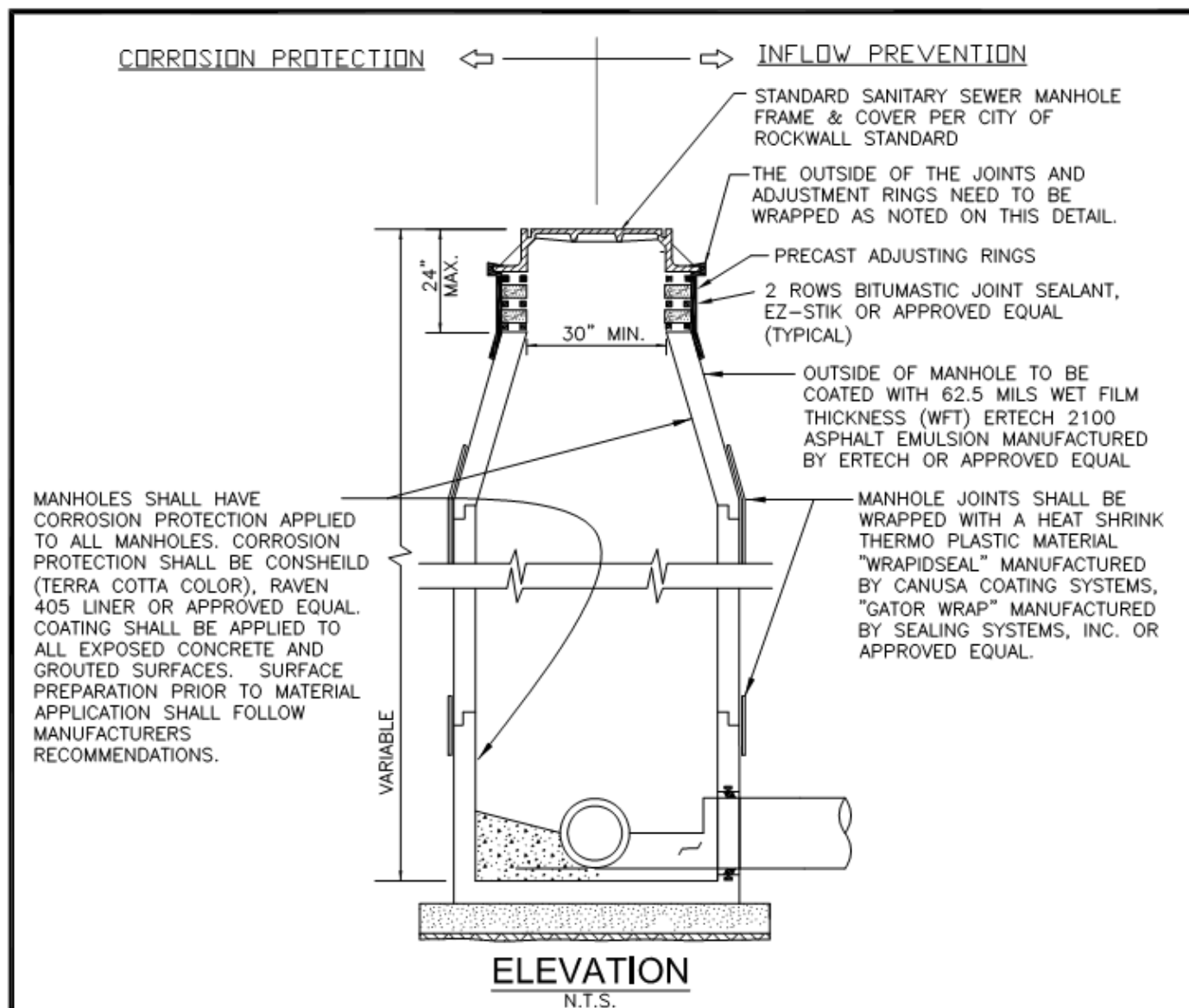
DRAWING NO.  
R-5020



- NOTES:
1. IF FALSE M.H. BOTTOMS ARE REQUIRED THEY SHALL BE CONSTRUCTED, INSTALLED AND REMOVED, PER STD. DWG. NO. 5100
  2. M.H.'S LOCATED OUTSIDE OF PAVING SHALL BE CONSTRUCTED WITH A CONCRETE MOW STRIP PER STANDARD DETAIL R-7005.
  3. REFER TO STD. DWG. NO. R-5031 FOR INFLOW PROTECTION AT MANHOLE GRADE RINGS AND ON THE OUTSIDE OF MANHOLE STRUCTURE.
  4. CAST IN PLACE BASE MUST BE A MINIMUM 12" THICK WITH #5 BARS @ 12" OC-EW (EACH WAY) AND SHALL EXTEND 1' BEYOND MANHOLE.
  5. CONCRETE SHALL BE 4,200 PSI (7.0 SACK/CY) 28 DAY STRENGTH.
  6. REINFORCING SHALL MEET OR EXCEED ASTM C478 REQUIREMENTS.
  7. INSTALL GREEN EMS DISK AT ALL MANHOLES.

WASTEWATER MANHOLE	CITY OF ROCKWALL		
CAST-IN-PLACE		DATE AUG '19	DRAWING NO. R-5030



INFLOW PREVENTION NOTES:

1. REQUIRED ON ALL SANITARY SEWER MANHOLES AND LIFT STATION WET WELLS AND VALVE VAULTS.

CORROSION PREVENTION NOTES:

1. TO CORROSION PROTECTIVE COATING PROCESS, PRESSURE WASH AND CLEAN STRUCTURE. FILL BUG HOLES, JOINTS, HONEYCOMBS AND AROUND PIPE PENETRATIONS WITH A CEMENTITIOUS REPAIR MATERIAL (CRM) AS NEEDED. USE STRONG SEAL MS2C MANUFACTURED BY THE STRONG COMPANY, INC. OR APPROVED EQUAL. THEN APPLY A MINIMUM OF 125 MILS ( $\frac{1}{8}$  INCH) THICKNESS OF A POLYURETHANE COATING MATERIAL (EXISTING MANHOLES REQUIRE A MINIMUM OF 250 MILS THICKNESS OF POLYURETANE COATING MATERIAL). FOR THE POLYURETHANE COATING MATERIAL USE RAVEN 405 LINER OR APPROVED EQUAL.
2. ADDITIONAL CLEANING, PREPARATION, AND REPAIR METHODS MAY BE REQUIRED FOR EXISTING MANHOLES DEPENDING ON CONDITION ASSESSMENT OF THE MANHOLE. CONTACT ENGINEERING DIVISION FOR ADDITIONAL SPECIFICATIONS.
3. SPARK TESTING IS REQUIRED FOR COATINGS. COST FOR TESTING IS SUBSIDIARY TO OTHER BID ITEMS. CITY INSPECTOR TO BE PRESENT FOR SPARK TESTING. CONTRACTOR TO PROVIDE WRITTEN SPARK TEST RESULTS TO CITY.
4. EXISTING BRICK MANHOLES SHALL BE REPLACED.
5. REQUIRED ON ALL WASTEWATER MANHOLES AND LIFT STATION WET WELLS.

WASTEWATER MANHOLE

CITY OF ROCKWALL

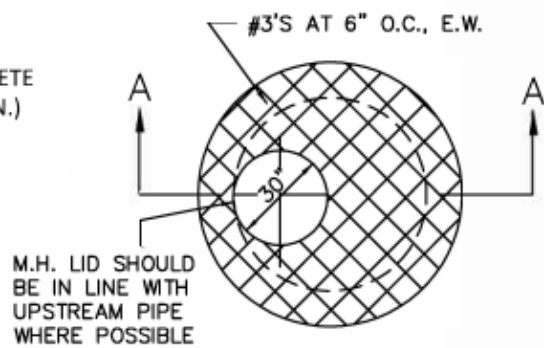
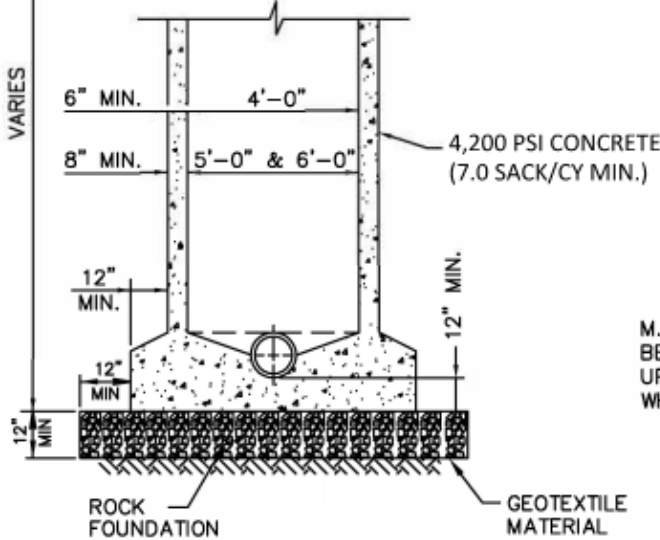
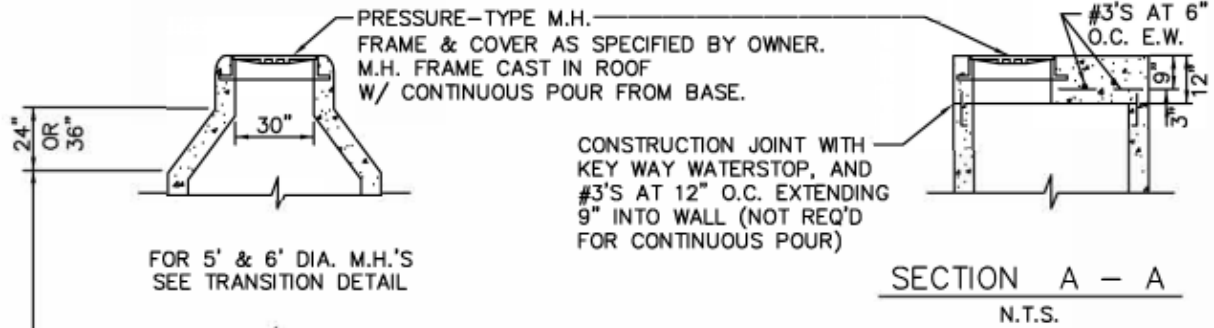


INFLOW PREVENTION &amp; CORROSION PROTECTION

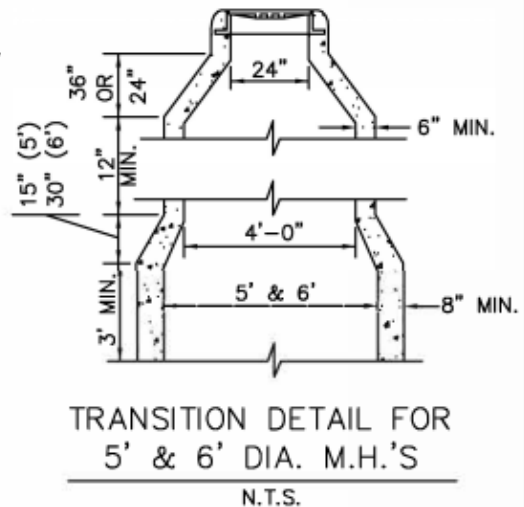
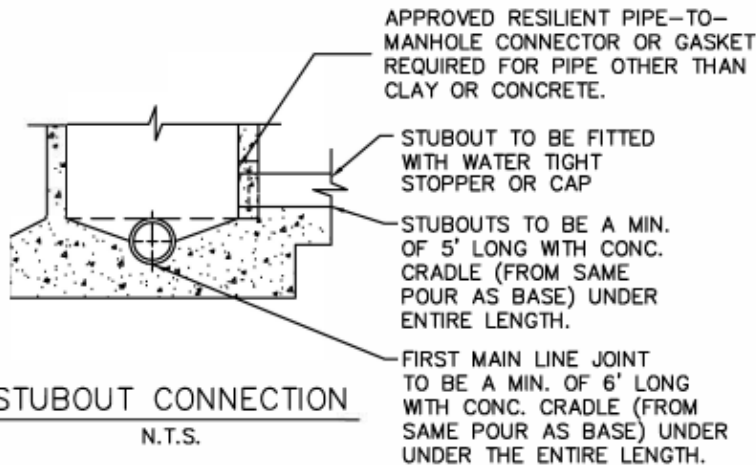
DATE  
AUG '19DRAWING NO.  
R-5031



CONCRETE CONE ← ROOF OPTIONS → REINFORCED CONCRETE SLAB  
N.T.S.



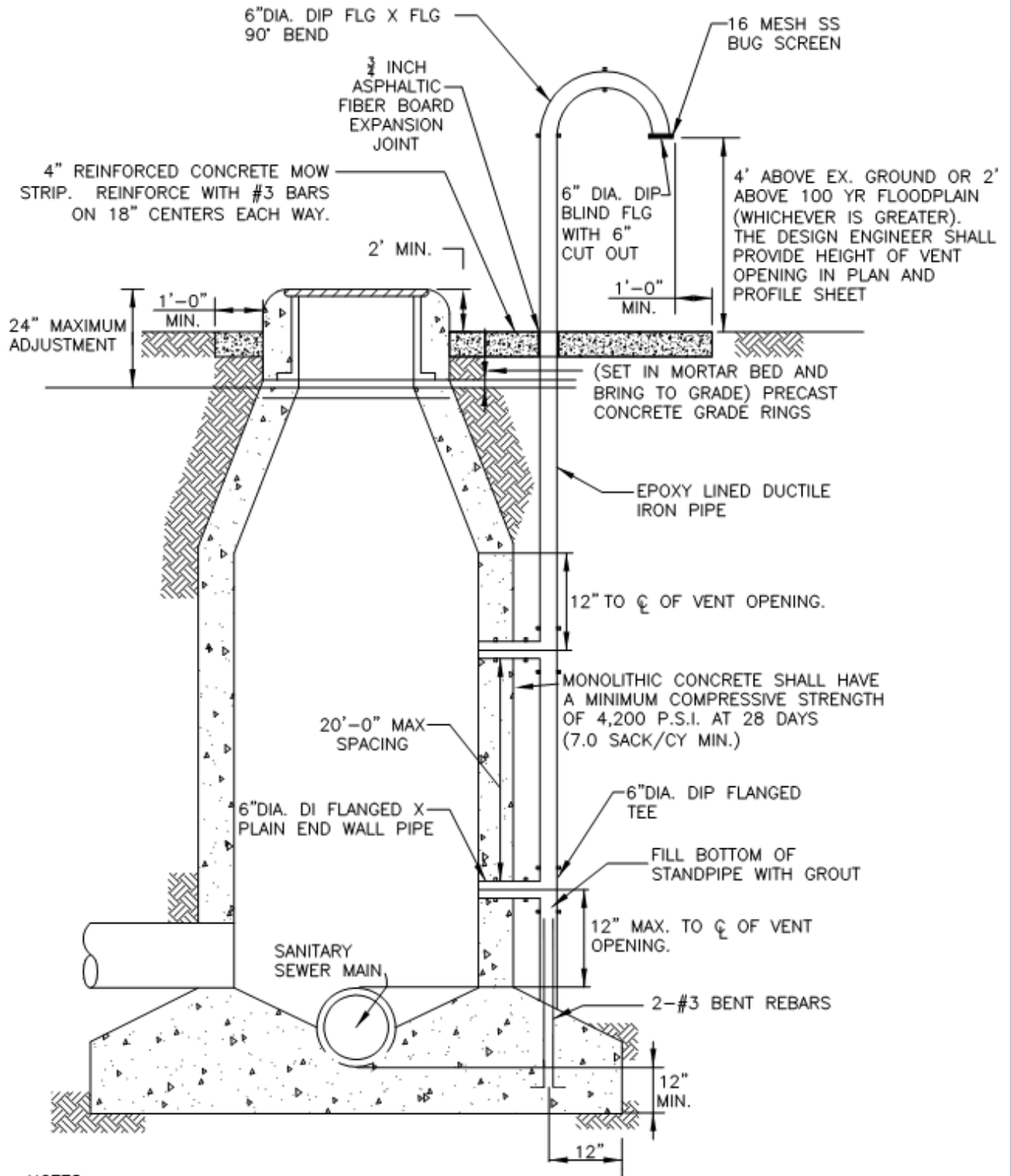
INSTALL GREEN EMS DISKS AT ALL MANHOLES.



WASTEWATER MANHOLE  
PRESSURE-TYPE


CITY OF ROCKWALL

STANDARD SPECIFICATION REFERENCE  
502.1.4.15\*  
DATE: Mar. 2018  
STANDARD DRAWING NO.: R-5050



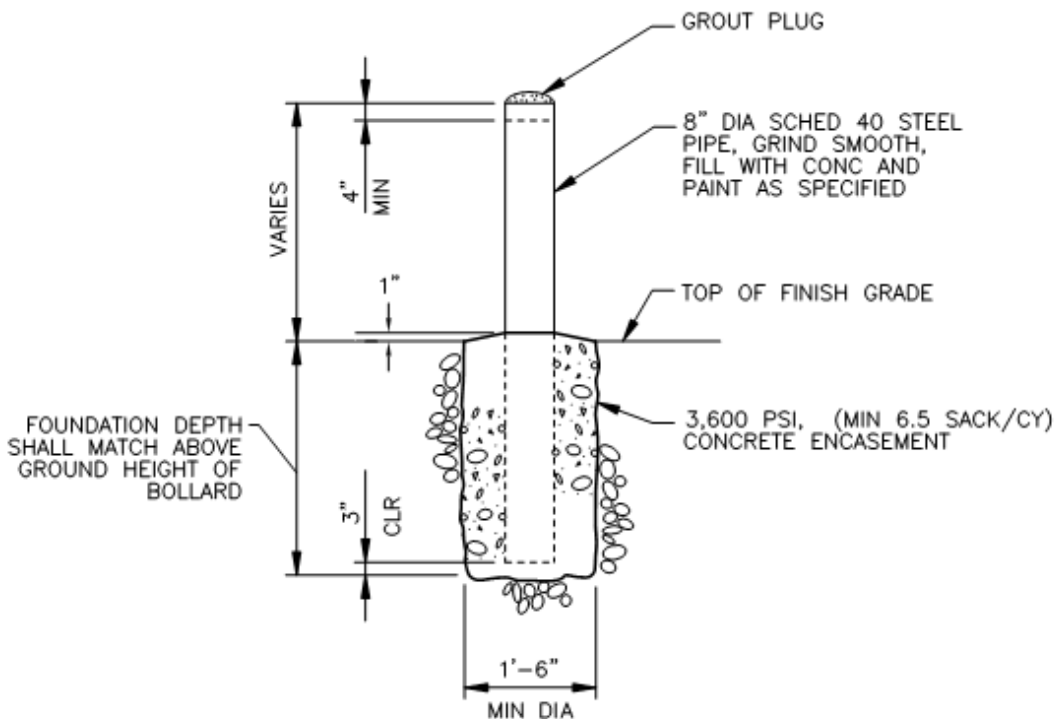
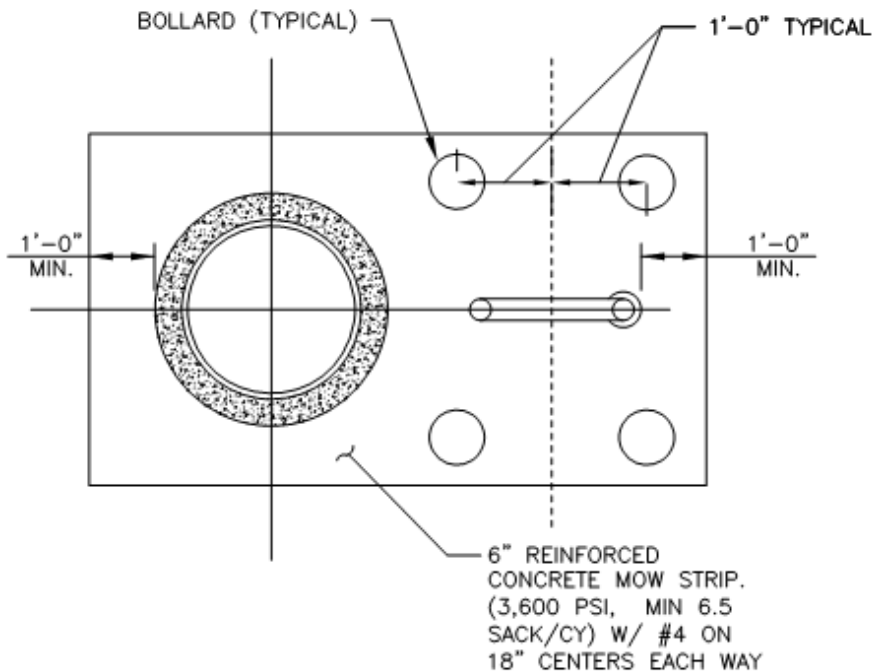
- NOTES:**
1. REFER TO STANDARD DETAIL R-5030 FOR MANHOLE. CONCRETE SHALL BE MONOLITHIC POUR.
  2. REFER TO STD. DWG. NO. R-5031 FOR INFLOW PROTECTION AT MANHOLE GRADE RINGS, MANHOLE JOINTS, AND ON OUTSIDE OF STRUCTURE.

SHEET 1 OF 2


WASTEWATER MANHOLE	CITY OF ROCKWALL		
VENTED		DATE AUG '19	DRAWING NO. R-5060

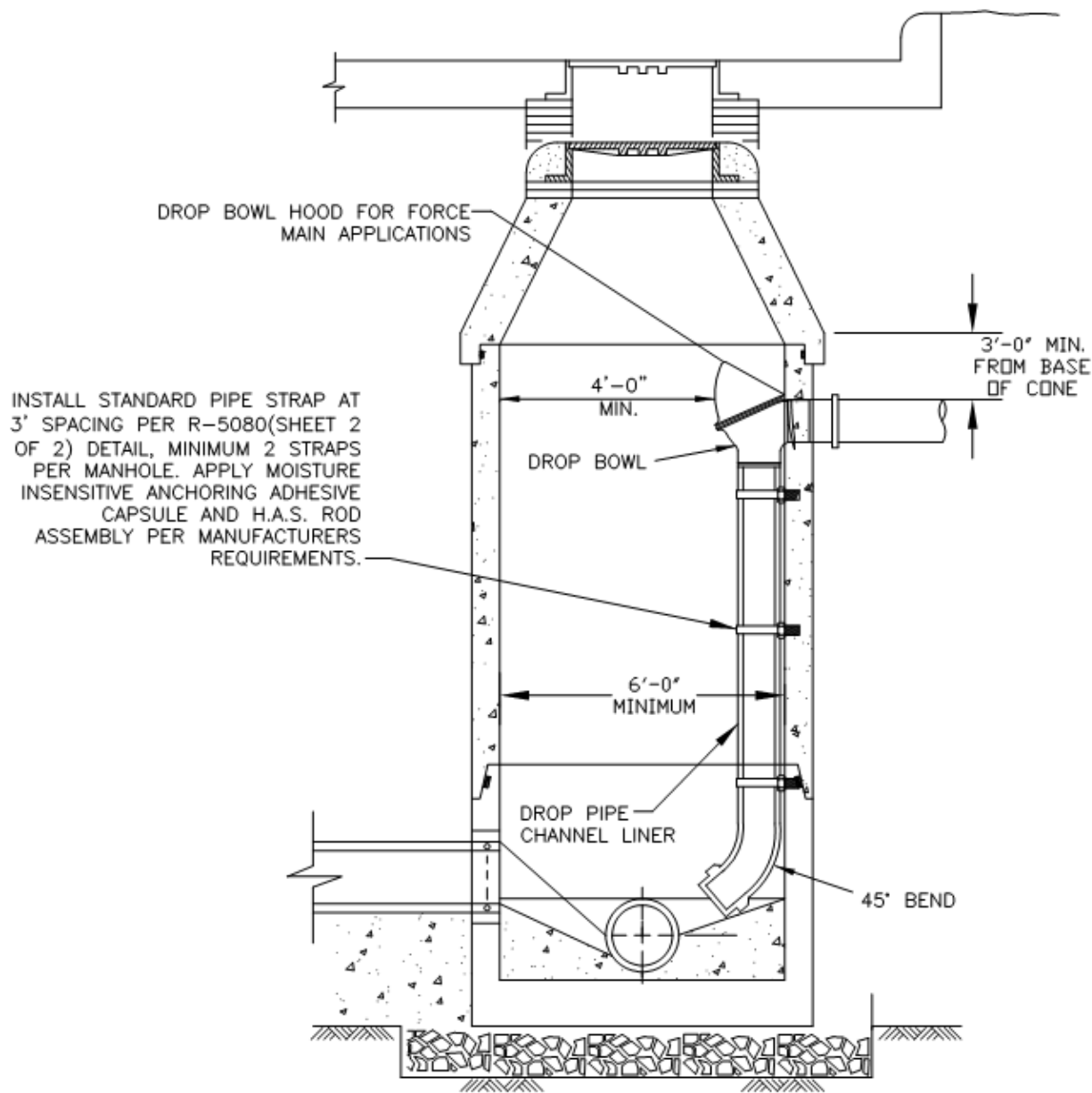


NOTES:  
 1. BOLLARD HEIGHT SHALL EXTEND TO 1 FOOT ABOVE THE OVERALL HEIGHT OF THE VENT PIPE.



SHEET 2 OF 2


WASTEWATER MANHOLE	CITY OF ROCKWALL		
VENTED		DATE AUG '19	DRAWING NO. R-5060



ELEVATION  
N.T.S.

NOTE:  
 1. DROP BOWL, DROP PIPE CHANNEL LINER AND STAINLESS STEEL PIPE CLAMPS AS MANUFACTURED BY RELINER/DURAN INC. OR APPROVED EQUAL.

SHEET 1 OF 2

WASTEWATER MANHOLE	CITY OF ROCKWALL		
DROP CONNECTIONS		DATE AUG '19	DRAWING NO. R-5080



**HVA ADHESIVE CAPSULE ANCHOR**

- A. DRILL HOLES WITH ANSI B212.15 MATCHED TOLERANCE CARBIDE TIPPED DRILL BITS WITH DRILL IN ROTO-HAMMER MODE OR USE A MATCHED TOLERANCE DIAMOND CORE DRILL BIT OF DIAMETER SPECIFIED BY HILTI.
- B. DRILLED HOLE SPECIFICATIONS (DIAMETER & DEPTH) SHALL COMPLY WITH HILTI SPECIFICATION OR ICC ESR 1562.
- C. ALLOWABLE LOADS MAY BE INCREASED BY 33-1/3% FOR SHORT-TERM WIND OR SEISMIC LOAD RESISTANCE (AW ICC ESR 1682 UNLESS NOT PERMITTED BY THE APPLICABLE BUILDING CODE).
- D. WHEN CONDUCTED, PROOF TEST ANCHORS IN THE FIELD TO 150-200% OF HILTI PUBLISHED ALLOWABLE TENSION LOAD UNLESS NOTED OTHERWISE IN A PROOF TEST LOAD TABLE. TORQUE TESTING IS NOT PERMITTED.
- E. ANCHORS SHALL BE TIGHTENED WITH A CALIBRATED TORQUE WRENCH. USE OF AN IMPACT WRENCH IS NOT PERMITTED.
- F. CONTACT HILTI TECHNICAL SUPPORT AT 1-800-879-8000 FOR INSTALLATION INSTRUCTIONS IN SUBMERGED WATER CONDITIONS.
- G. CONTACT HILTI TECHNICAL SUPPORT AT 1-800-879-8000 FOR ADDITIONAL ASSISTANCE WITH HVA ADHESIVE ANCHOR INSTALLATIONS.
- H. INSTALLATION INSTRUCTIONS:

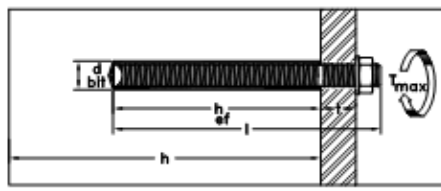
- H.1. FOR HVA ADHESIVE CAPSULES WITH H.A.S. THREADED RODS:
  - 1. DRILL ANCHOR HOLE WITH A CARBIDE BIT (SEE NOTE 1 ABOVE), TO SPECIFIED EMBEDMENT DEPTH.
  - 2. CLEAN HOLE WITH COMPRESSED AIR OR BLOW OUT PUMP. INSERT NOZZLE TO BOTTOM OF HOLE.
  - 3. IF USING MATCHED TOLERANCE CORE BIT, REMOVE STANDING WATER FROM HOLE.
  - 4. INSERT APPROPRIATE HVU CAPSULE INTO HOLE WITH POINTED END FIRST. CAPSULE LENGTH IS LONGER THAN STANDARD EMBEDMENT AND WILL PROTRUDE FROM HOLE. DO NOT CUT OFF ANY PART OF THE HVU CAPSULE.
  - 5. THREAD NUT ONTO ROD.
  - 6. PLACE A WASHER ON FIRST NUT AND THREAD BLACK SETTING NUT DOWN ON WASHER.
  - 7. TIGHTEN NUTS TOGETHER SO THAT BLACK SETTING WASHER IS AT TOP OF ROD.
  - 8. INSERT SQUARE DRIVE SHAFT INTO HAMMER DRILL AND ATTACH PROPER IMPACT SOCKET.
  - 9. WITH HAMMER DRILL ON ROTARY HAMMER, ENGAGE TOP NUT OF HAS ROD ASSEMBLY AND ROTOHAMMER ROD THROUGH CAPSULE(S) INTO THE HOLE. STOP DRILL ROTATION IMMEDIATELY UPON REACHING BOTTOM OF HOLE.
  - 10. DO NOT DISTURB OR LOAD ANCHOR BEFORE CURING TIME ELAPSES.

HVA INSTALLATION SPECIFICATION TABLE FOR H.A.S. RODS

DETAILS	HAS Rod Size	1/2	3/8	1/2	5/8	3/4	7/8	1	1-1/4
d <sub>tip</sub> : nominal bit diameter	in.	15/32	9/16	11/16	7/8	1	1-1/8	1-3/8	1-3/8
h <sub>nom</sub> : ■ std. depth of embed. ■ capsule length	in.	3-1/2	4-1/4	5	6-5/8	6-5/8	8-1/4	12	12
t : max. thickness fastened	in.	1	1-1/2	1-3/4	2	2-1/4	2-1/2	2-3/4	2-3/4
t <sub>max</sub> : max. tightening torque	All Hilti Rods	ft-lb	18	30	75	150	175	235	400
h : minimum base material thickness	h <sub>ef=nom</sub>	in.	5-1/4	6-3/8	7-1/2	10	10	12-3/8	18
	h <sub>ef=hnom</sub>	in.	1.0h + 2	1.0h + 2	1.0h + 2	1.0h + 2	1.0h + 2	1.0h + 2 1/4	1.0h + 3
Recommended Hilti Rotary Hammer Drill			TE-5,15, 18M,25	TE-18M,25,55,76		TE-55, 76		TE-76	

For S<sub>1</sub> 1 inch - 25.4mm, 18-h 1.4 Nm  
Curing Time Table (Approximate)

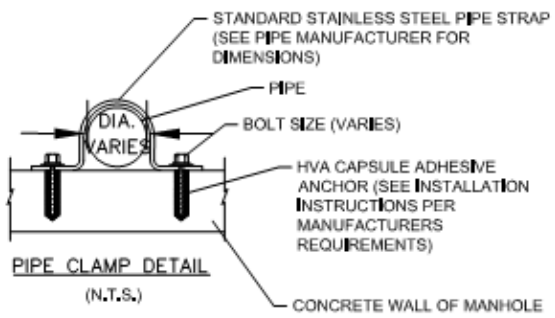
Approx. Curing Time	Base Material Temperature
20 Minutes	ABOVE 68° F/20° C
30 Minutes	50° F/10° C
1 Hour	32° F/0° C
5 Hour	23° F/-5° C



HILTI HVA ADHESIVE CAPSULE ANCHOR OR APPROVED EQUAL

**INSTALLATION INSTRUCTIONS:**

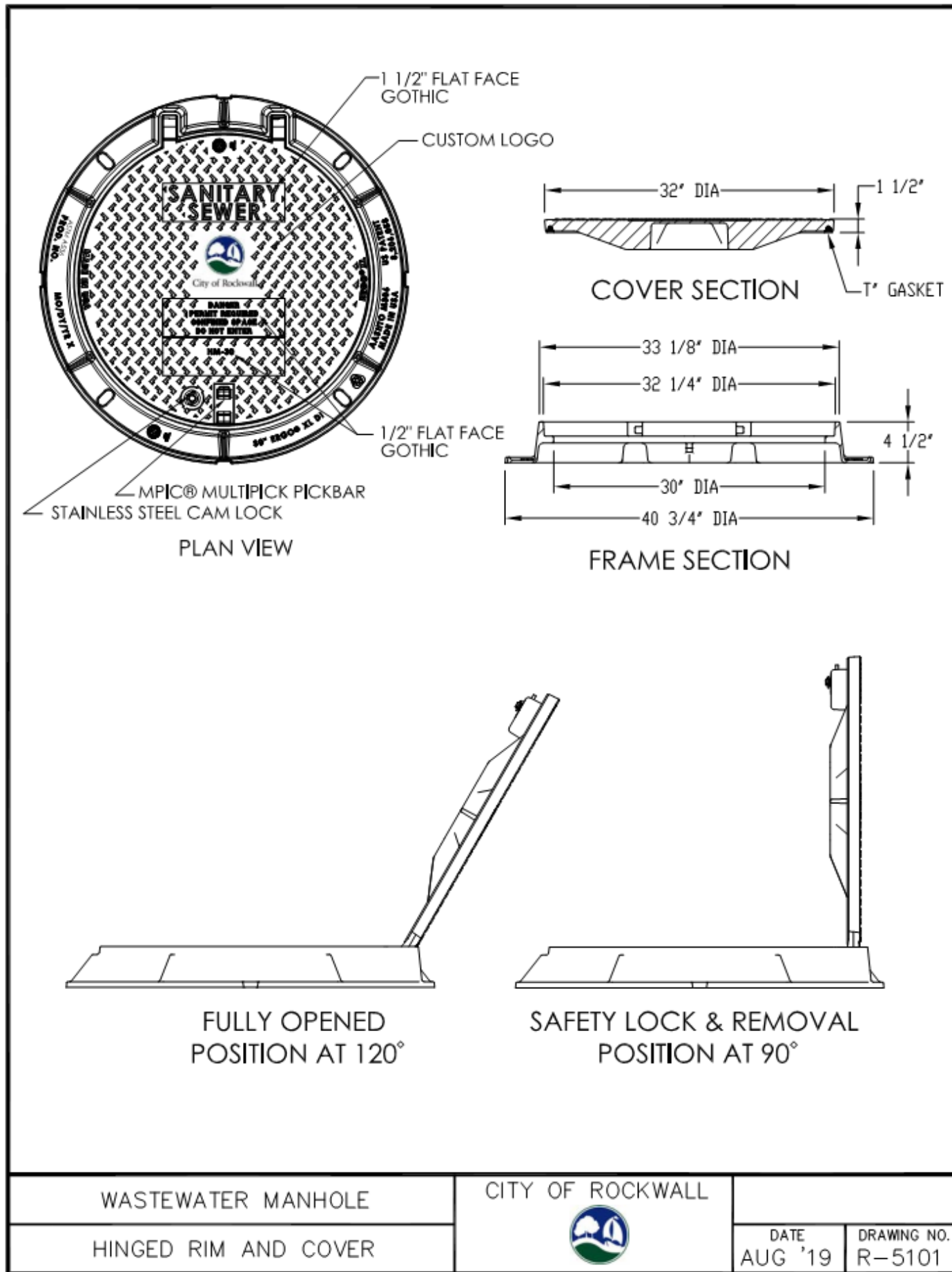
- 1. SET THE DRILL DEPTH GAUGE AND DRILL A HOLE TO THE REQUIRED HOLE DEPTH. IMPORTANT: CLEAN OUT DUST AND DEBRIS. USE COMPRESSED AIR OR VACUUM AT BOTTOM OF THE HOLE. WHEN USING THE HILTI MATCHED TOLERANCE DIAMOND CORE BIT, IMMEDIATELY REMOVE STANDING WATER.
- 2. INSERT APPROPRIATE DIAMETER HVU ADHESIVE CAPSULE INTO PRE-DRILLED HOLE IN BASE MATERIAL. NOTE: THE BEST METHOD FOR SETTING MULTIPLE CAPSULES IS TO CRUSH THE FIRST CAPSULE(S) INTO THE HOLE AND THEN INSERT THE NEXT CAPSULE. DO NOT CUT OFF CAPSULES PARTIALLY PROTRUDING FROM THE HOLE.
- 3. CAPSULE LENGTH IS LONGER THAN STANDARD EMBED, DEPTH AND WILL PROTRUDE FROM THE HOLE.
- 4. THREAD A H.A.S. NUT ON THE H.A.S. ROD, PLACE A WASHER ON TOP OF THE FIRST NUT AND THEN THREAD A BLACK SETTING NUT DOWN ON TOP OF THE WASHER. TIGHTEN THE TWO NUTS TOGETHER "LOCKING" THE WASHER BETWEEN THEM. THE TOP NUT SHOULD BE FLUSH WITH THE TOP OF THE ROD.
- 5. INSERT A SQUARE DRIVE SHAFT INTO THE HAMMER DRILL AND ATTACH THE PROPER IMPACT SOCKET. AT THE ROTARY HAMMER DRILL SETTING, ENGAGE THE TOP NUT OF THE HAS ROD ASSEMBLY WITH THE SOCKET AND DRIVE THE ROD DOWN THROUGH THE CAPSULE(S). STOP DRILL ROTATION IMMEDIATELY UPON REACHING BOTTOM OF HOLE.
- 6. DO NOT DISTURB OR LOAD THE SET ANCHOR BEFORE THE SPECIFIED CURING TIME ELAPSES.

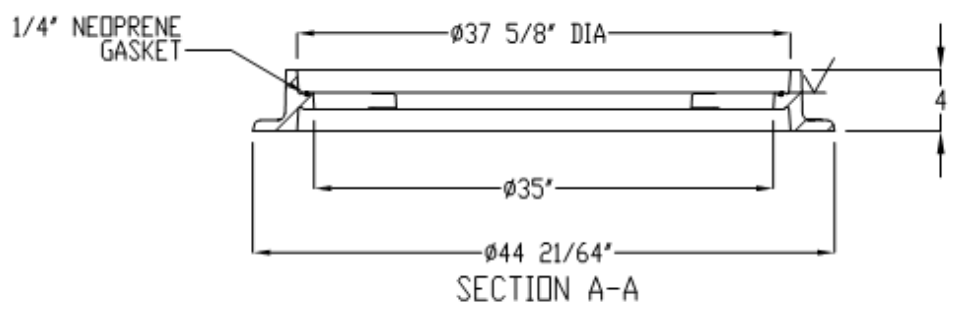
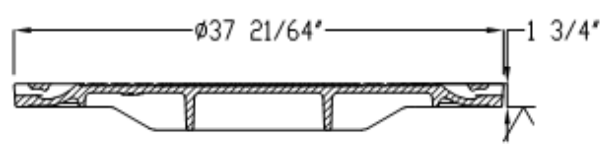
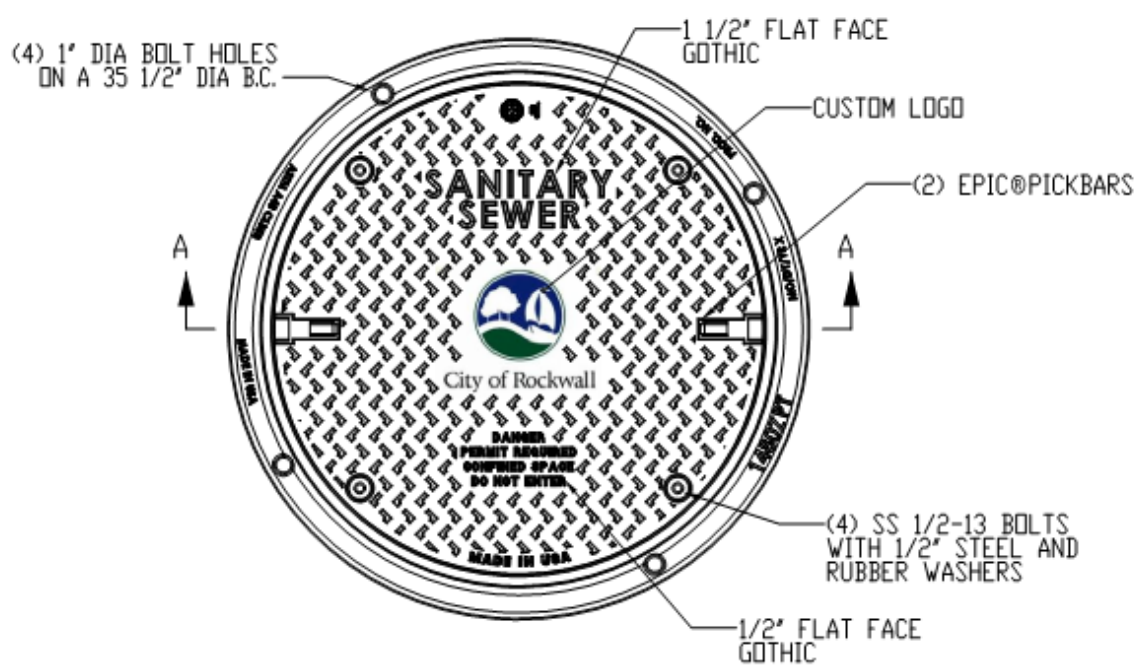



DROP FIXTURE ANCHOR (N.T.S.)

SHEET 2 OF 2

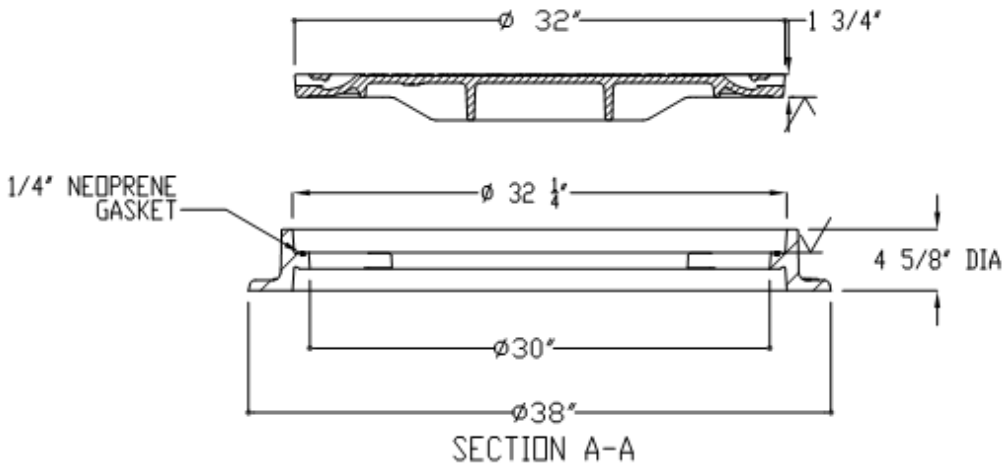
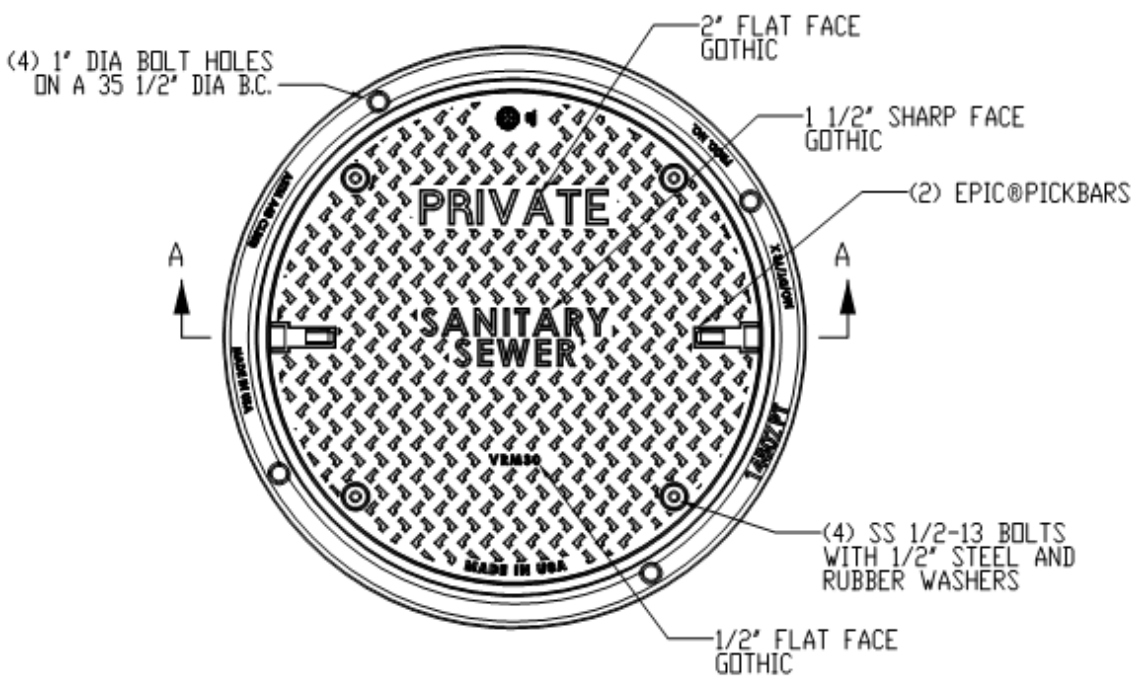
<b>WASTEWATER MANHOLE</b>	<b>CITY OF ROCKWALL</b>		
<b>DROP CONNECTIONS</b>		DATE <b>AUG '19</b>	DRAWING NO. <b>R-5080</b>






WASTEWATER MANHOLE	CITY OF ROCKWALL		
BOLT AND GASKET RIM AND COVER		DATE AUG '19	DRAWING NO. R-5102





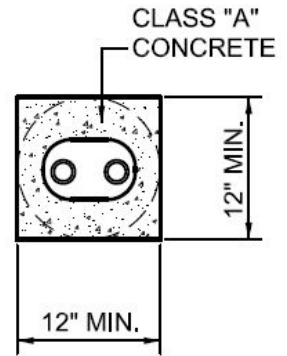
WASTEWATER MANHOLE	CITY OF ROCKWALL		
PRIVATE RIM AND COVER		DATE AUG '19	DRAWING NO. R-5103



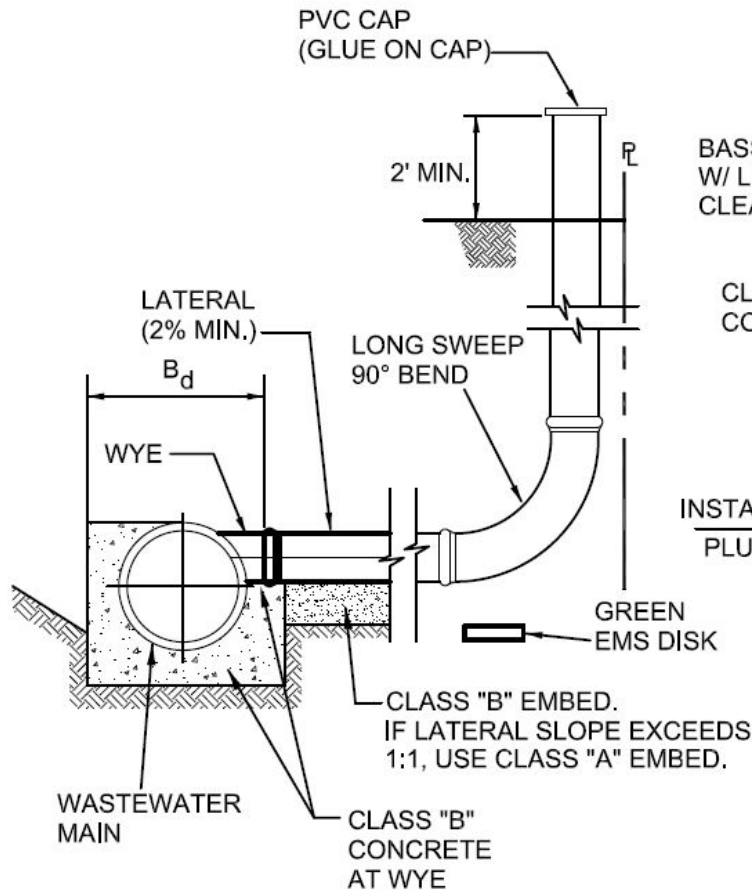


CLASS CONCRETE	BAGS CEMENT PER C.Y.	MIN. STRENGTH 28 - DAY PSI
A	5.5	3000
B	4	2000

THE CLEANOUT MAY BE PLACED IN THE PARKWAY OR SIDEWALK, IF NECESSARY



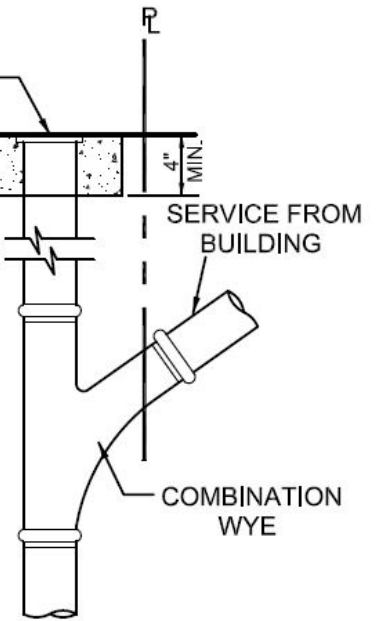
TOP VIEW OF CLEANOUT



BASS & HAYS 404 W/ LID & GASKET CLEANOUT

CLASS "A" CONCRETE

INSTALLED BY PLUMBER



PLUMBER TO CUT CLEANOUT RISER TO INSTALL COMBINATION WYE TO CORRESPOND W/ GRADE OF THE PIPE LEADING FROM BUILDING. AFTER INSTALLATION OF THE WYE, INSERT CLEANOUT INTO THE TOP OF THE RISOR.

WASTEWATER LATERAL

CITY OF ROCKWALL

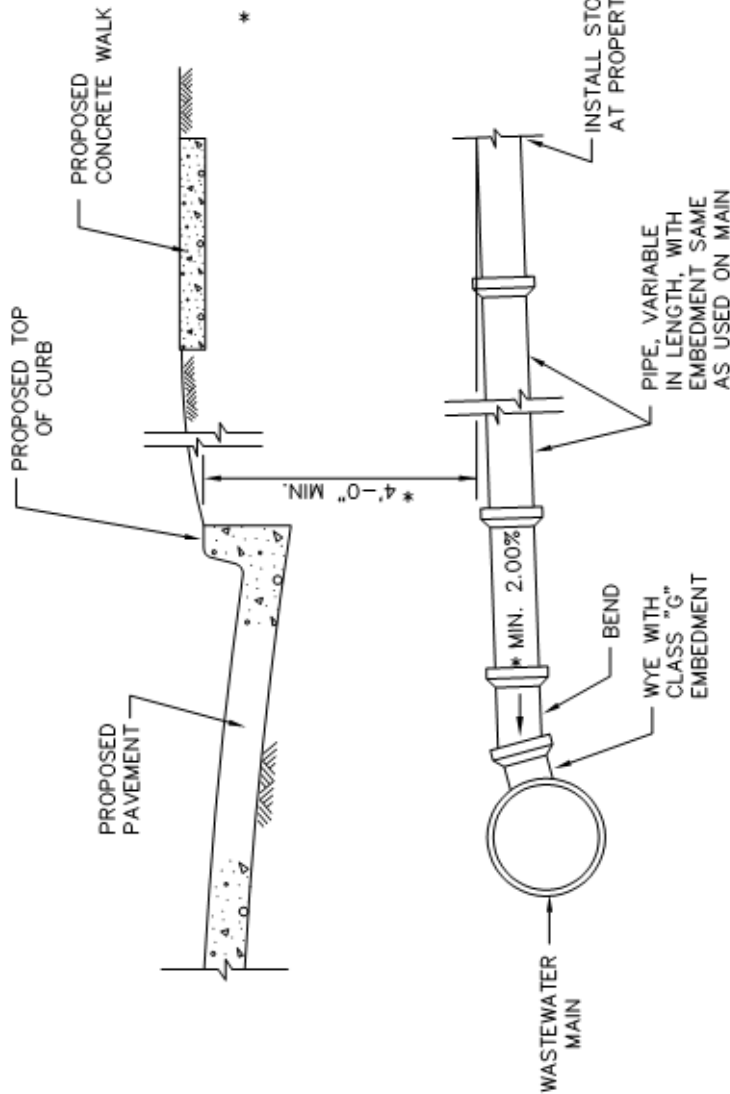
CONNECTIONS – RESIDENTIAL



DATE AUG. '15 DRAWING NO. R-5120



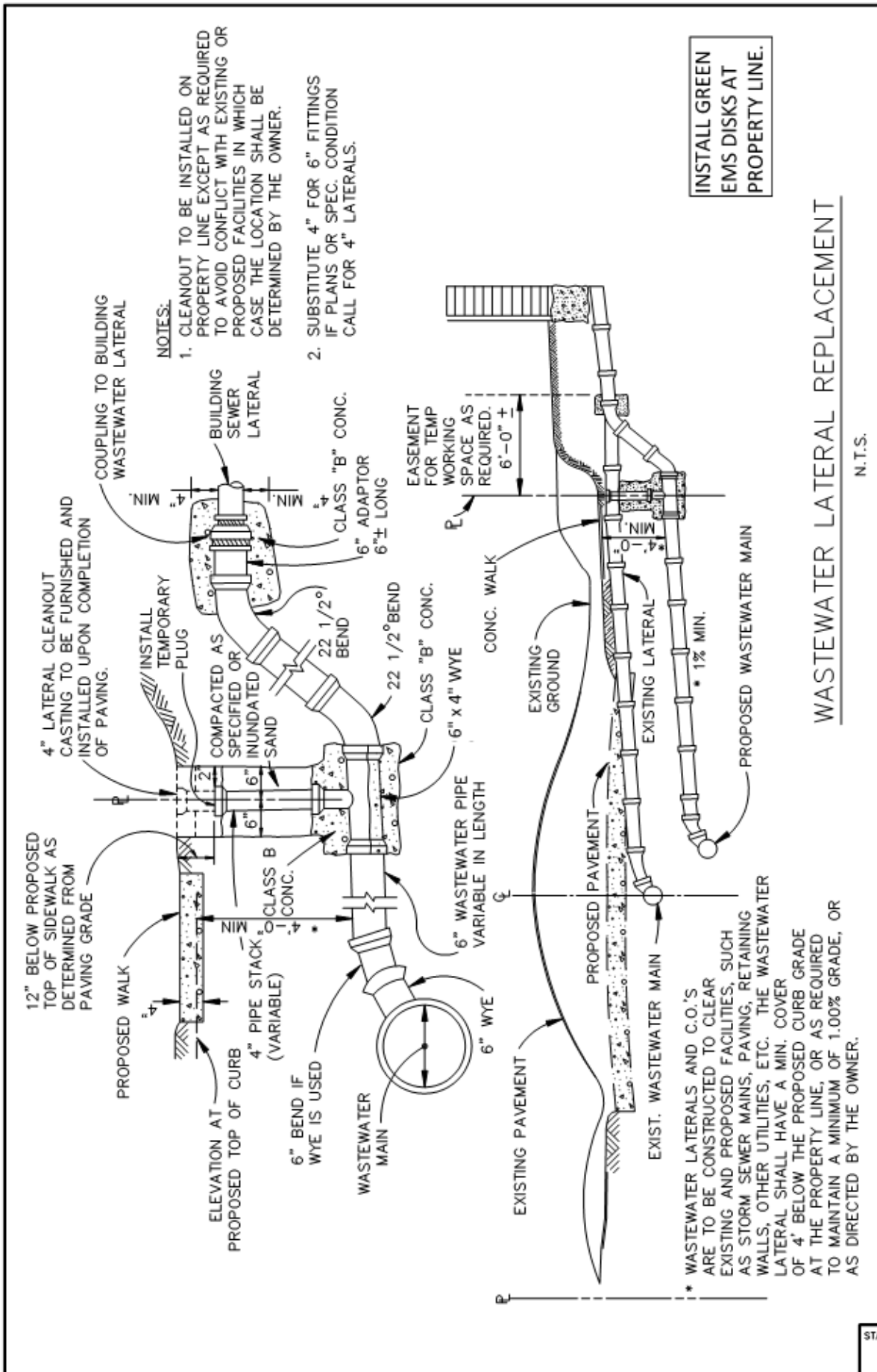
INSTALL GREEN  
EMS DISKS AT  
END OF LATERAL.



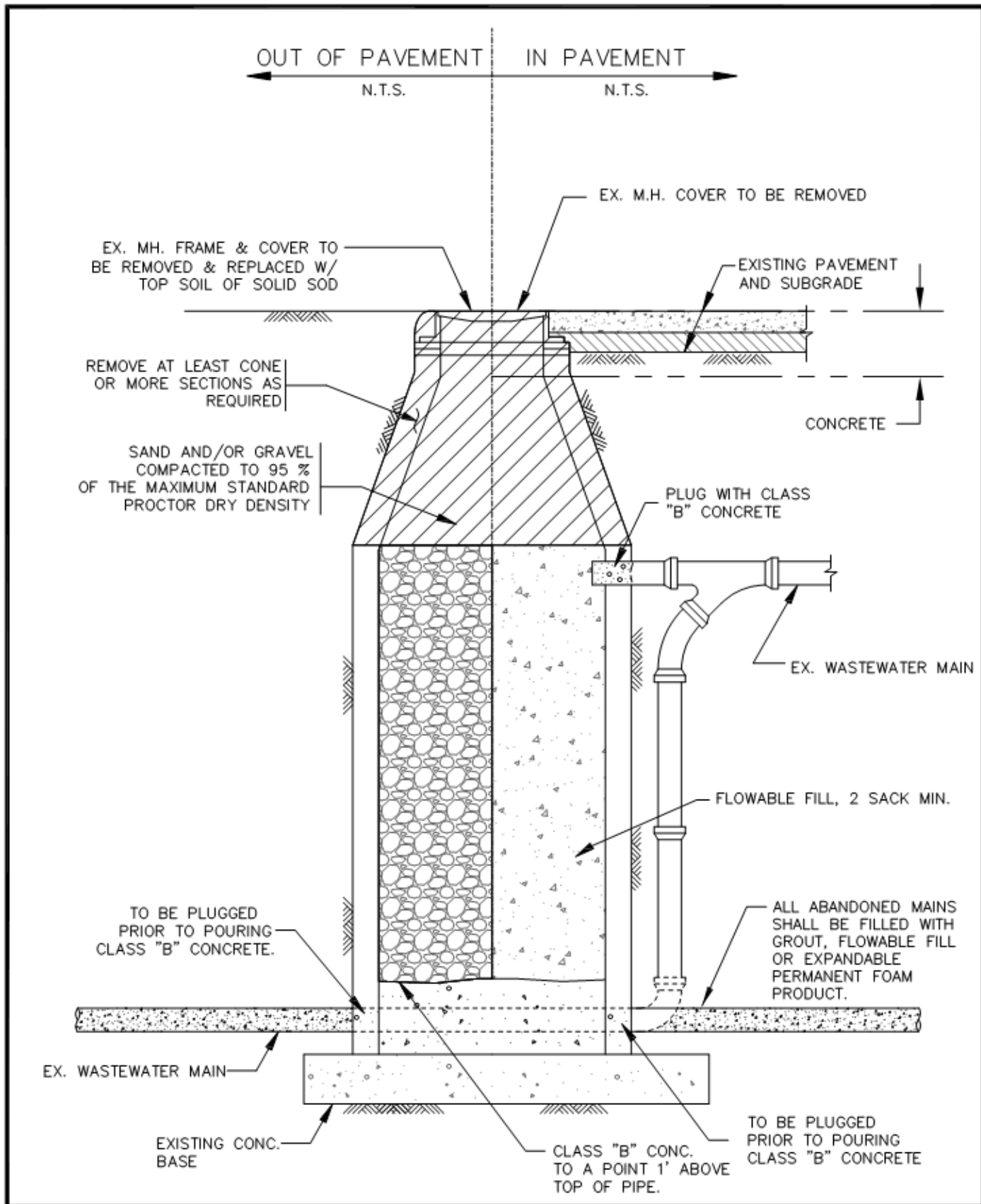
\* WASTEWATER LATERALS ARE TO BE CONSTRUCTED TO CLEAR EXISTING AND PROPOSED FACILITIES, SUCH AS STORM SEWER MAINS, RETAINING WALLS, OTHER UTILITIES, ETC. THE WASTEWATER LATERAL SHALL HAVE A MINIMUM COVER OF 4'-0" BELOW THE PROPOSED CURB GRADE AT THE PROPERTY LINE, DETERMINED FROM PAVING GRADE, OR AS REQUIRED TO MAINTAIN A MINIMUM OF 2.00% GRADE, OR AS DIRECTED BY THE OWNER.


WASTEWATER LATERAL STUBOUT  
(FOR FUTURE CONNECTION, 4" OR 6" AS SPECIFIED)  
N.T.S.

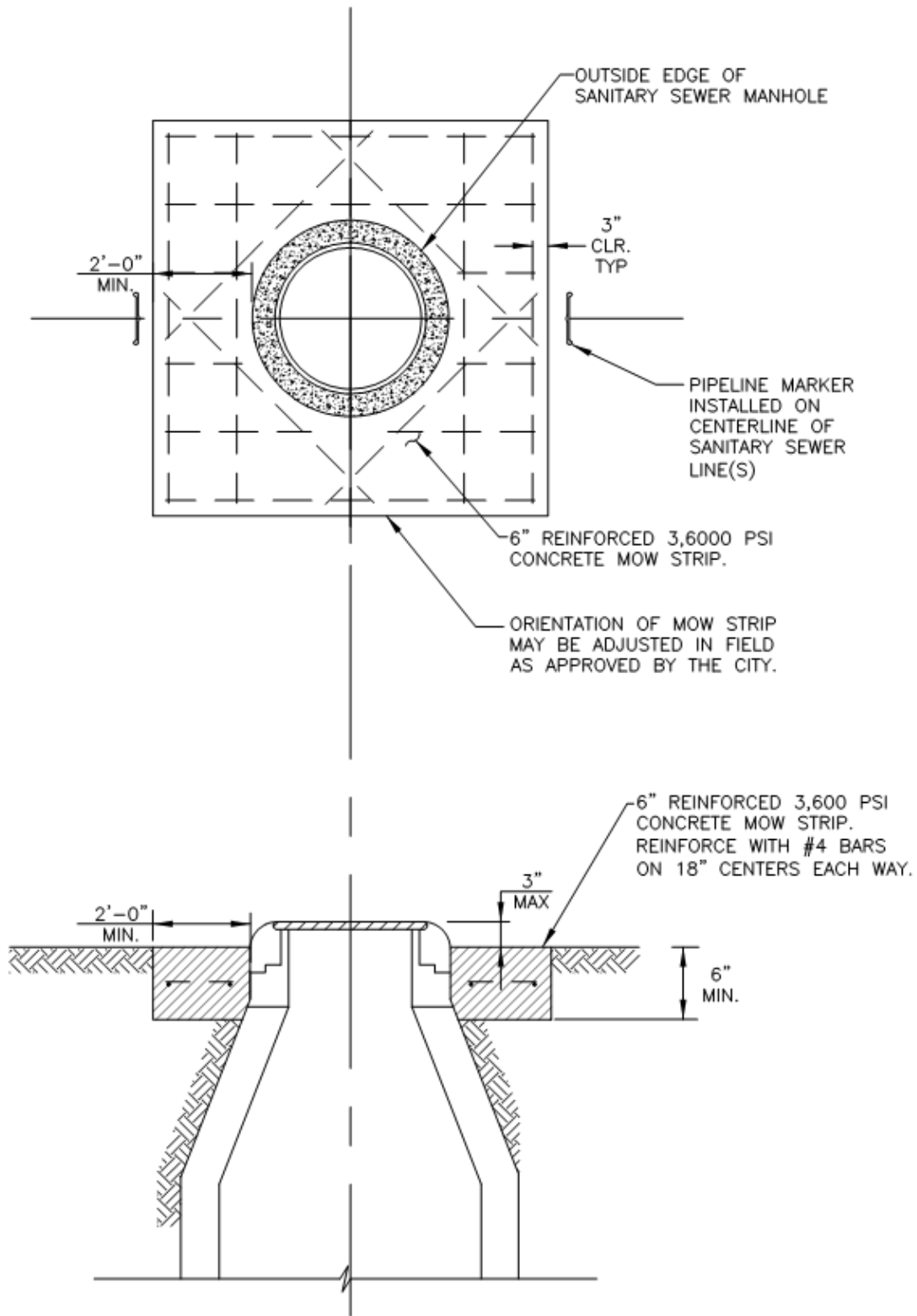
		STANDARD SPECIFICATION REFERENCE	502.10
		DATE	Mar. 2018
WASTEWATER LATERAL STUBOUT IN ADVANCE OF PAVING		STANDARD DRAWING NO.	R-5150
CITY OF ROCKWALL		STANDARD DRAWING NO. R-5150	




WASTEWATER LATERAL REPLACEMENT IN ADVANCE OF PAVING	CITY OF ROCKWALL 	STANDARD SPECIFICATION REFERENCE 502.10
		DATE Mar. 2018
		STANDARD DRAWING NO. R-5160



<p><b>ABANDONMENT OF MANHOLE</b></p>	<p><b>CITY OF ROCKWALL</b></p>		
<p><b>INSIDE AND OUTSIDE OF PAVEMENT</b></p>		<p>DATE <b>AUG '19</b></p>	<p>DRAWING NO. <b>R-5170</b></p>



MANHOLE AND VALVE VAULT	CITY OF ROCKWALL		
MOW STRIP		DATE AUG '19	DRAWING NO. R-5180







## SECTION 8.06 | DIVISION 6000. STORM WATER DRAINAGE

TABLE 8.6: REVISIONS TO NCTCOG'S DIVISION 6000 STORM WATER DRAINAGE

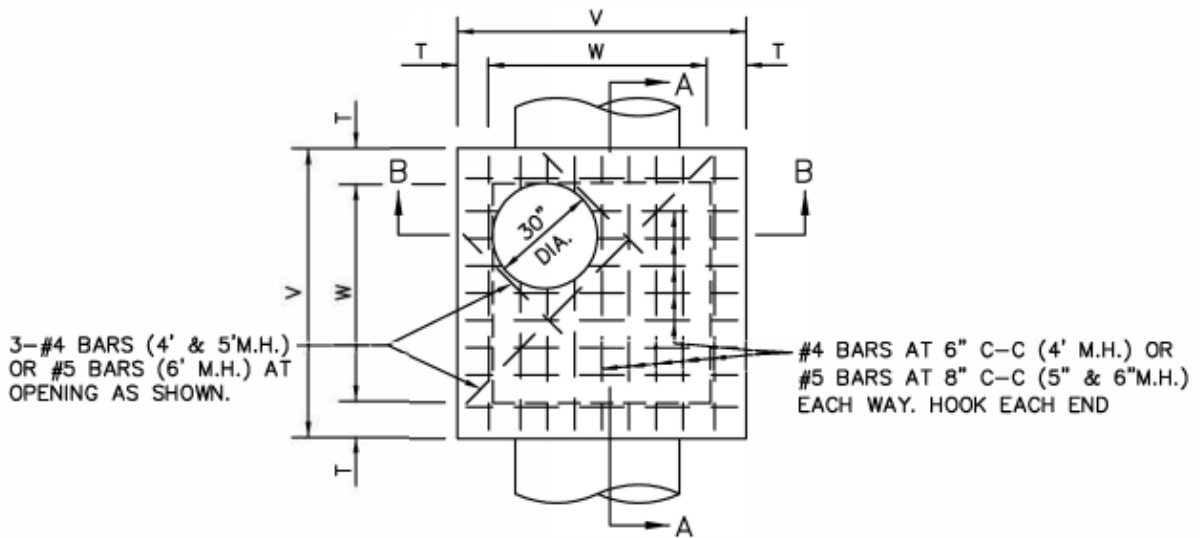
NOTES: (1) DELETED NCTCOG DRAWING; (2) REVISED NCTCOG DRAWING (SEE REVISIONS BELOW); (3) ADDED ROCKWALL STANDARD DRAWING (SEE DRAWING BELOW); AND (4) ADDED CURRENT TXDOT STANDARDS

REVISED	DRAWING NO.	DESCRIPTION
(1)	6010A	STORM WATER MANHOLE – 4', 5', 6' SQUARE
(3)	R-6010A	STORM WATER MANHOLE – 4', 5', 6' SQUARE
(1)	6010B	STORM WATER MANHOLE – 4', 5', 6' SQUARE
(3)	R-6010B	STORM WATER MANHOLE – 4', 5', 6' SQUARE
(1)	6020A	CURB INLET – 5', 10' 15' OR 20' OPENING
(3)	R-6020A	CURB INLET – 5', 10' 15' OR 20' OPENING
(1)	6020B	CURB INLET – CROSS SECTION & INLET THROAT
(3)	R-6020B	CURB INLET – CROSS SECTION & INLET THROAT
(1)	6020C	CURB INLET – REBAR & M.H. FRAME & COVER
(3)	R-6020C	CURB INLET – REBAR & M.H. FRAME & COVER
(1)	6020D	CURB INLET – BILL OF REINFORCING STEEL
(3)	R-6020D	CURB INLET – BILL OF REINFORCING STEEL
(1)	6020E	CURB INLET – SUMMARY OF QUANTITIES
(3)	R-6020E	CURB INLET – SUMMARY OF QUANTITIES
(3)	R-6022	ALLEY CURB INLET – UNDER PAVING – 5', 10' 15' OR 20' OPENING
(3)	R-6025A	CURB INLET UNDER PAVEMENT – 5', 10' 15' OR 20' OPENING
(3)	R-6025B	CURB INLET UNDER PAVEMENT – CROSS SECTION & CENTER BEAM
(3)	R-6025C	CURB INLET UNDER PAVEMENT – INLET THROAT & M.H. FRAME & COVER
(3)	R-6025D	CURB INLET UNDER PAVEMENT – GENERAL NOTES
(1)	6030A	CURB INLET RECESSED – 5', 10' 15' OR 20' OPENING
(3)	R-6030A	CURB INLET RECESSED – 5', 10' 15' OR 20' OPENING
(1)	6030B	CURB INLET RECESSED – CROSS SECTION & CENTER BEAM
(3)	R-6030B	CURB INLET RECESSED – CROSS SECTION & CENTER BEAM
(1)	6030C	CURB INLET RECESSED – INLET THROAT & M.H. FRAME & COVER
(3)	R-6030C	CURB INLET RECESSED – INLET THROAT & M.H. FRAME & COVER
(1)	6030D	CURB INLET RECESSED – GENERAL NOTES
(3)	R-6030D	CURB INLET RECESSED – GENERAL NOTES
(1)	6040	DROP INLET – 2', 4', 5', OR 6' SQUARE
(3)	R-6040	DROP INLET – 2', 4', 5', OR 6' SQUARE
(1)	6050	FULL CHANNEL LINING – CONCRETE REINFORCED
(3)	R-6050	FULL CHANNEL LINING – CONCRETE REINFORCED
(1)	6060	CONCRETE APRON – VERTICAL HEADWALL
(3)	R-6060	CONCRETE APRON – VERTICAL HEADWALL
(1)	6070	CONCRETE APRON - SLOPING HEADWALL
(3)	R-6070	CONCRETE APRON - SLOPING HEADWALL
(3)	R-6080	UNDERDRAIN/FRENCH DRAIN – UNDER SIDEWALK – RESIDENTIAL STREET
(4)		TXDOT: SINGLE BOX CULVERT – CAST-IN-PLACE AND PRECAST
(4)		TXDOT: MULTIPLE BOX CULVERT – CAST-IN-PLACE
(4)		TXDOT: WINGWALLS FOR SINGLE & MULTI-BOX CULVERTS
(4)		TXDOT: CONCRETE HEADWALLS FOR PIPE CULVERTS
(4)		TXDOT: SAFETY END TREATMENT FOR BOX CULVERTS
(4)		TXDOT: SAFETY END TREATMENT FOR PIPE CULVERTS

**NOTE:** STORM SEWER HEADWALLS, WINGWALLS, BOX CULVERTS AND SAFETY PIPE RUNNERS SHALL BE PER TEXAS DEPARTMENT OF TRANSPORTATION STANDARD DETAILS AND MADE PART OF THE CITY OF ROCKWALL STANDARD DETAILS.

TXDOT STANDARD DRAWINGS SHALL BE MODIFIED AS FOLLOWS:

- (1) ALL CONCRETE FOR STRUCTURES SHALL BE CLASS F (4200 PSI, MINIMUM 7.0 SACK CEMENT).
- (2) NO FLY ASH IS ALLOWED IN CONCRETE FOR STRUCTURES.



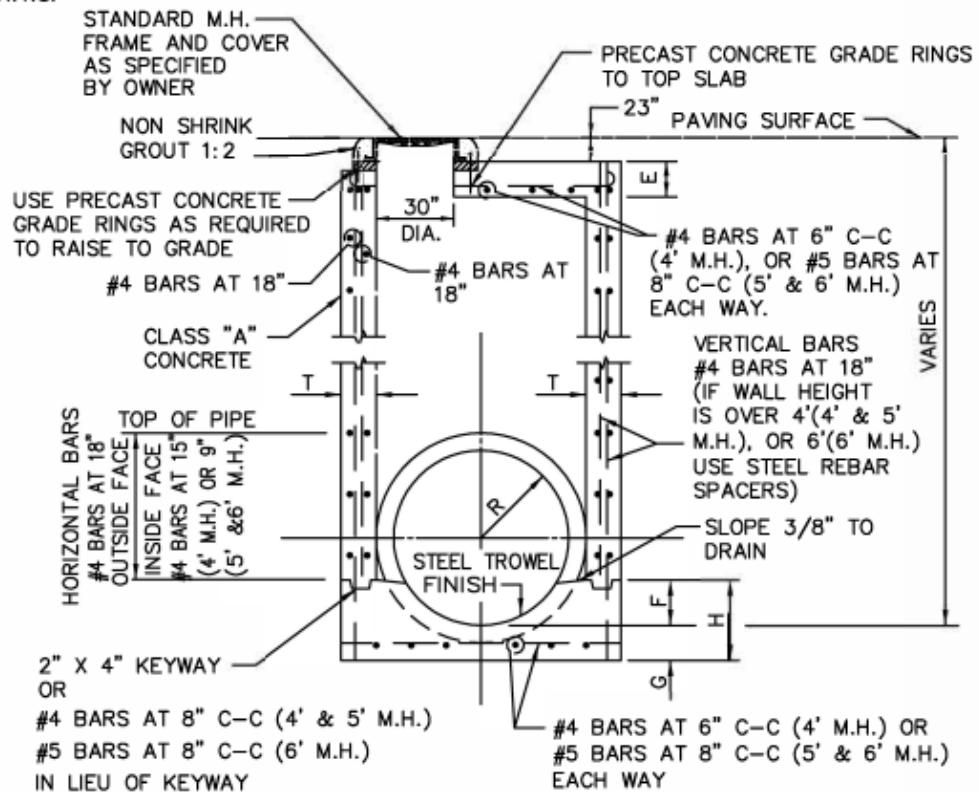
M.H. SIZE(W)	V	T	E	F	G	H
4'	5'-4"	8"	6"	9"	6"	1'-3"
5'	6'-4"	8"	6"	12"	8"	1'-8"
6'	7'-6"	9"	9"	16"	10"	2'-2"

TABLE OF DIMENSIONS

N.T.S.

PLAN  
N.T.S.

ALL CONCRETE STRUCTURES SHALL BE CLASS F (4200psi, MIN. 7.0 SACK CEMENT). NO FLY ASH IS ALLOWED IN CONCRETE STRUCTURES.



SECTION B-B  
N.T.S.

STORM WATER MANHOLE  
4', 5', OR 6' SQUARE

CITY OF ROCKWALL



STANDARD SPECIFICATION REFERENCE  
502.1.4.1\*

DATE  
Mar. 2018

STANDARD DRAWING NO.  
R-6010A



#4 BARS AT 6" C-C (4' M.H.), OR  
#5 BARS AT 8" C-C (5' & 6' M.H.)  
EACH WAY HOOKED  
EACH END

#4 BARS  
AT 18"  
OUTSIDE FACE

#4 BARS  
AT 18" INSIDE FACE

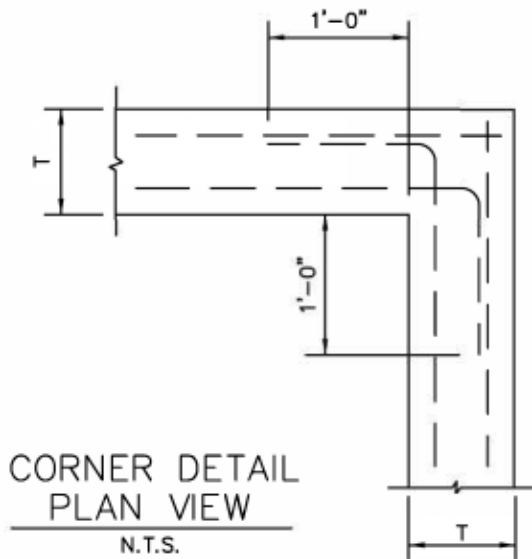
#4 BARS  
AT 18"  
OUTSIDE FACE

#4 BARS AT 15"  
(4' M.H.) OR 9" (5'  
& 6' M.H.) INSIDE FACE.

#4 DOWELS AT 18"  
ALL AROUND EXCEPT  
IN WAY OF PIPE

#4 BARS AT 6" C-C  
(4' M.H.), OR #5 BARS AT  
8" C-C (5' & 6' M.H.)  
EACH WAY

**SECTION A-A**  
N.T.S.



**NOTES:**

1. SLOPE INVERT OF MANHOLE AS INDICATED ON PLAN-PROFILE SHEET.
2. LAYERS OF REINFORCING STEEL NEAREST THE INTERIOR AND EXTERIOR SURFACE SHALL HAVE A COVER OF 2" TO THE CENTER OF BARS, UNLESS OTHERWISE NOTED.
3. ALL CONCRETE STRUCTURES SHALL BE CLASS F (4200psi, MIN. 7.0 SACK CEMENT).
4. NO FLY ASH IS ALLOWED IN CONCRETE STRUCTURES.

**STORM WATER MANHOLE**  
4', 5', OR 6' SQUARE

**CITY OF ROCKWALL**



STANDARD SPECIFICATION REFERENCE

502.1.4.1\*

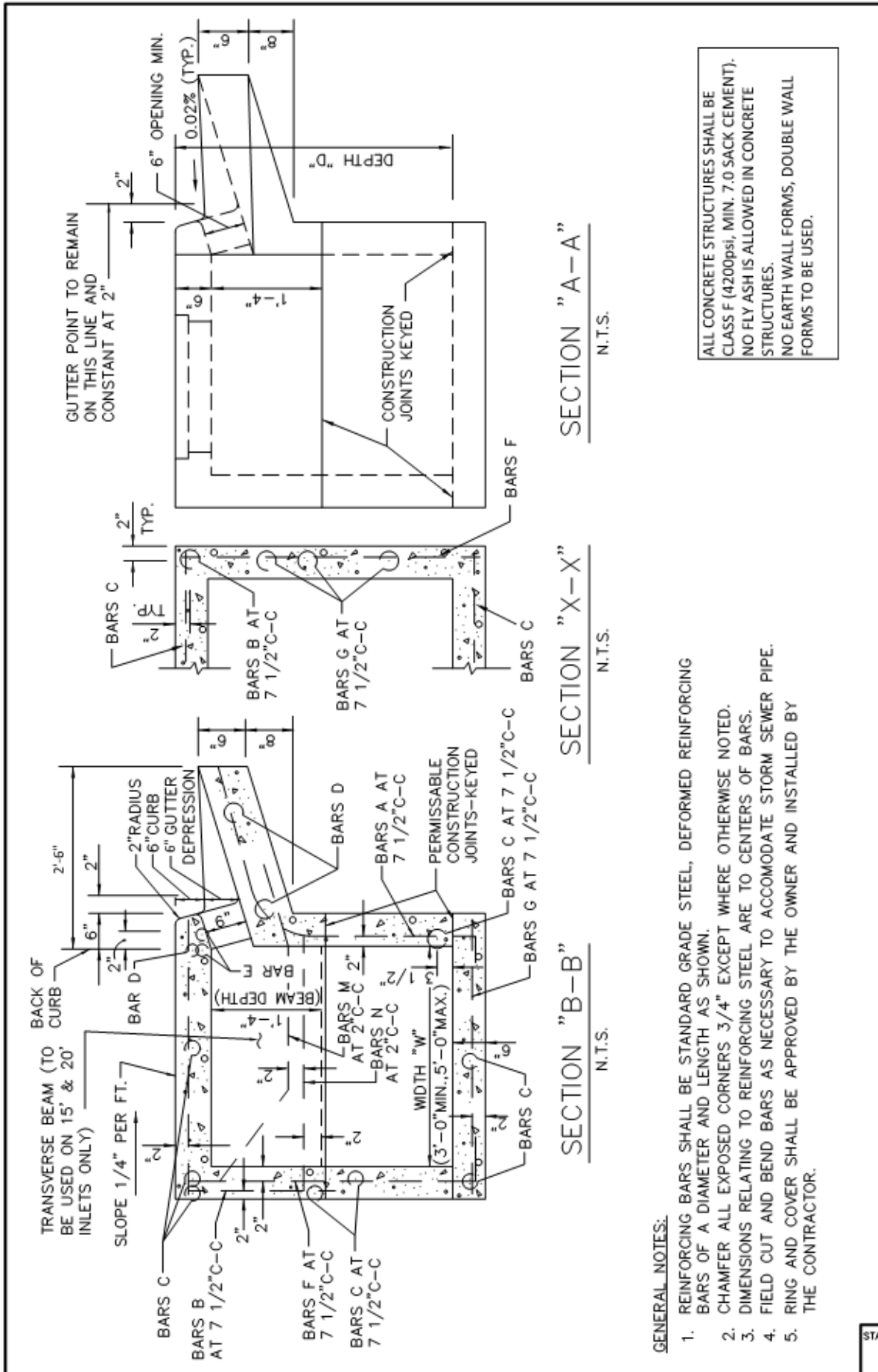
DATE

Mar. 2018

STANDARD DRAWING NO.

R-6010B





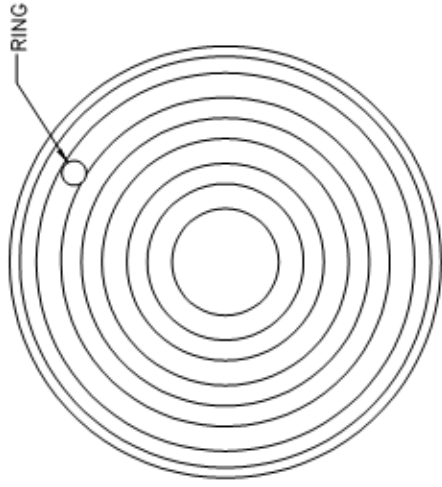
**GENERAL NOTES:**

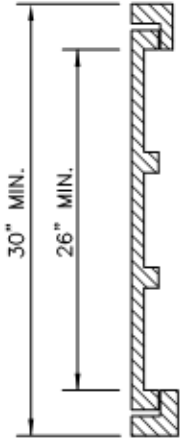
1. REINFORCING BARS SHALL BE STANDARD GRADE STEEL, DEFORMED REINFORCING BARS OF A DIAMETER AND LENGTH AS SHOWN.
2. CHAMFER ALL EXPOSED CORNERS 3/4" EXCEPT WHERE OTHERWISE NOTED.
3. DIMENSIONS RELATING TO REINFORCING STEEL ARE TO CENTERS OF BARS.
4. FIELD CUT AND BEND BARS AS NECESSARY TO ACCOMMODATE STORM SEWER PIPE.
5. RING AND COVER SHALL BE APPROVED BY THE OWNER AND INSTALLED BY THE CONTRACTOR.

ALL CONCRETE STRUCTURES SHALL BE CLASS F (4200psi, MIN. 7.0 SACK CEMENT). NO FLY ASH IS ALLOWED IN CONCRETE STRUCTURES. NO EARTH WALL FORMS, DOUBLE WALL FORMS TO BE USED.

STANDARD DRAWING NO. <b>R-6020B</b>	CITY OF ROCKWALL 	STANDARD SPECIFICATION REFERENCE 702
CURB INLET CROSS SECTION & INLET THROAT		DATE AUG. 2019
		STANDARD DRAWING NO. R-6020B








CAST IRON  
FRAME AND COVER  
N.T.S.

CITY OF ROCKWALL

STANDARD SPECIFICATION REFERENCE  
702

DATE  
Mar. 2018

STANDARD DRAWING NO.  
R-6020C



CITY OF ROCKWALL

STANDARD DRAWING NO.  
6020C

CURB INLET

REBAR & M.H. FRAME & COVER

BARS C LGTH. OPEN. +0'-8"  
BARS D LGTH. OPEN. +11'-8"  
#4 BARS C & D  
N.T.S.

#4 BARS B  
N.T.S.

#4 BARS G  
N.T.S.

ALL CONCRETE STRUCTURES SHALL BE CLASS F (4200psi, MIN. 7.0 SACK CEMENT). NO FLY ASH IS ALLOWED IN CONCRETE STRUCTURES. INLET LID TO BE LOCKING.

#4 BARS F  
N.T.S.

#5 BARS N  
N.T.S.

#4 BARS E  
N.T.S.

#3 BARS M  
N.T.S.

#4 BARS J  
N.T.S.





SUMMARY OF QUANTITIES FOR CURB INLETS

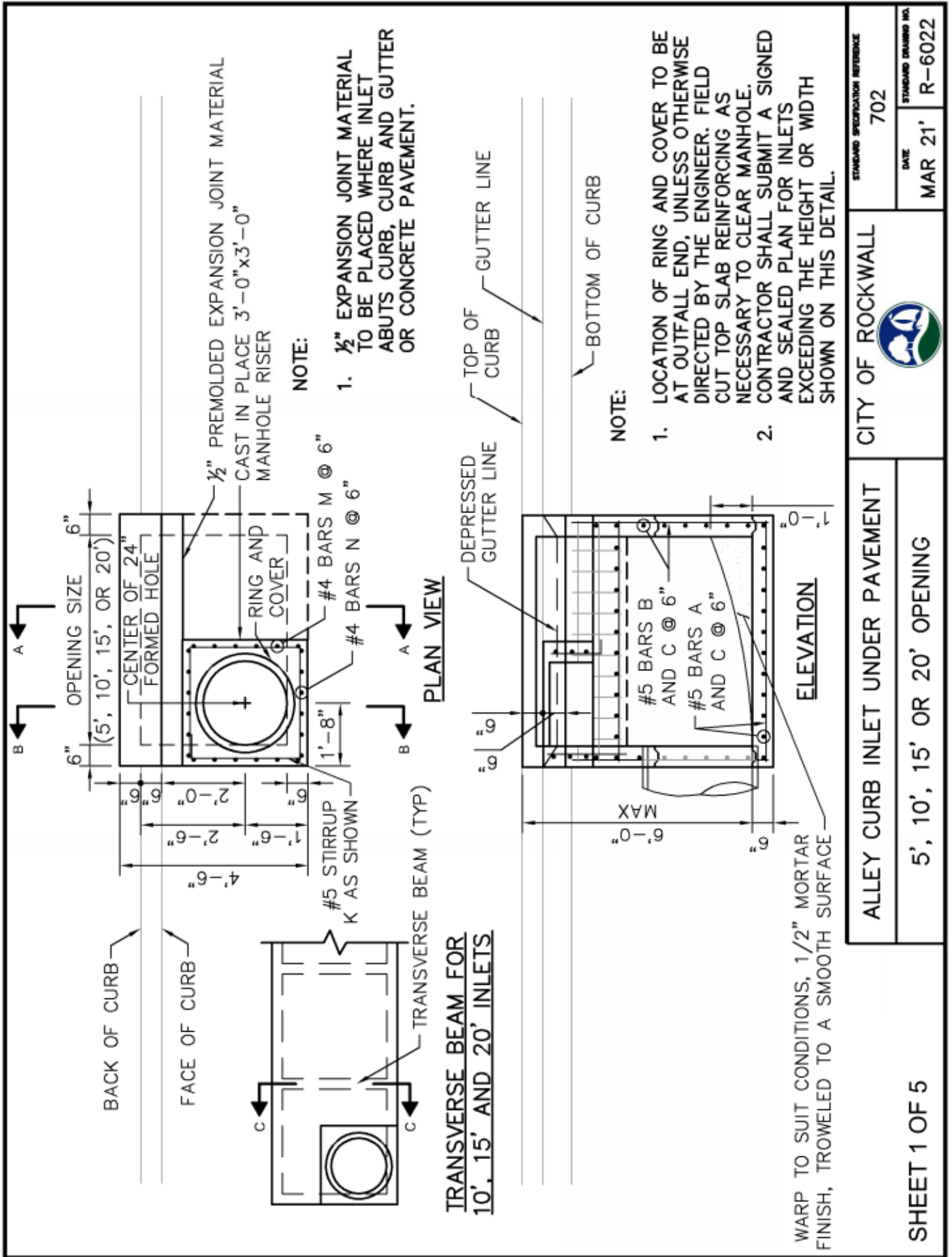
DEPTH "D"	5'-0" OPENING						10'-0" OPENING						15'-0" OPENING						20'-0" OPENING					
	WIDTH 3'-0"		WIDTH 4'-0"		WIDTH 5'-0"		WIDTH 3'-0"		WIDTH 4'-0"		WIDTH 5'-0"		WIDTH 3'-0"		WIDTH 4'-0"		WIDTH 5'-0"		WIDTH 3'-0"		WIDTH 4'-0"		WIDTH 5'-0"	
	CONC C.Y.	STEEL LBS.	CONC C.Y.	STEEL LBS.	CONC C.Y.	STEEL LBS.	CONC C.Y.	STEEL LBS.	CONC C.Y.	STEEL LBS.	CONC C.Y.	STEEL LBS.	CONC C.Y.	STEEL LBS.	CONC C.Y.	STEEL LBS.	CONC C.Y.	STEEL LBS.	CONC C.Y.	STEEL LBS.	CONC C.Y.	STEEL LBS.	CONC C.Y.	STEEL LBS.
3'-6"	2.62	306	2.95	332	3.28	373	4.12	479	4.64	521	5.20	564	5.69	667	6.40	721	7.10	775	7.20	846	8.11	909	9.03	976
3'-9"	2.70	309	3.04	341	3.39	373	4.25	494	4.78	536	5.34	579	5.87	687	6.58	741	7.30	796	7.42	874	8.34	937	9.27	1010
4'-0"	2.78	328	3.14	364	3.49	399	4.38	518	4.92	565	5.49	610	6.05	718	6.77	776	7.49	835	7.64	909	8.58	976	9.51	1046
4'-3"	2.87	334	3.23	370	3.59	406	4.51	526	5.06	573	5.64	619	6.22	729	6.95	787	7.69	847	7.87	922	8.81	990	9.75	1061
4'-6"	2.95	356	3.32	394	3.69	431	4.64	558	5.20	607	5.79	656	6.40	770	7.14	830	7.88	891	8.09	973	9.04	1043	9.99	1115
4'-9"	3.03	361	3.41	410	3.79	438	4.77	566	5.34	616	5.94	665	6.57	780	7.32	841	8.07	903	8.31	986	9.27	1056	10.23	1129
5'-0"	3.12	367	3.51	416	3.90	445	4.90	574	5.47	624	6.09	674	6.75	791	7.51	853	8.27	915	8.53	999	9.50	1070	10.47	1144
5'-3"	3.20	383	3.60	424	4.00	465	5.03	600	5.61	652	6.23	704	6.93	827	7.69	890	8.46	955	8.76	1044	9.73	1118	10.71	1194
5'-6"	3.28	389	3.69	430	4.10	472	5.16	608	5.75	661	6.38	713	7.11	837	7.88	901	8.66	967	8.98	1057	9.97	1131	10.95	1208
5'-9"	3.37	405	3.78	451	4.20	495	5.29	635	5.89	690	6.53	744	7.28	874	8.07	940	8.85	1007	9.20	1102	10.20	1178	11.19	1258
6'-0"	3.45	415	3.88	460	4.30	504	5.42	646	6.03	702	6.68	757	7.45	888	8.25	954	9.05	1022	9.42	1119	10.43	1196	11.43	1276
6'-3"	3.53	425	3.97	470	4.41	515	5.55	661	6.17	718	6.83	773	7.63	908	8.44	975	9.24	1044	9.64	1147	10.66	1223	11.67	1305
6'-6"	3.62	437	4.06	486	4.51	532	5.68	681	6.31	739	6.97	797	7.81	935	8.62	1005	9.43	1057	9.87	1178	10.89	1258	11.92	1340
6'-9"	3.70	441	4.15	490	4.61	537	5.81	688	6.45	747	7.12	806	7.98	945	8.81	1015	9.63	1066	10.09	1191	11.12	1272	12.15	1355
7'-0"	3.78	460	4.25	510	4.71	560	5.94	716	6.59	777	7.27	837	8.16	981	8.99	1053	9.82	1126	10.31	1237	11.35	1319	12.40	1404
7'-3"	3.86	465	4.34	516	4.81	567	6.07	724	6.72	785	7.42	846	8.33	992	9.18	1065	10.02	1138	10.53	1249	11.59	1333	12.64	1418
7'-6"	3.95	477	4.43	529	4.91	570	6.20	742	6.86	804	7.57	866	8.51	1016	9.36	1089	10.21	1163	10.75	1290	11.82	1365	12.88	1451
7'-9"	4.03	491	4.53	544	5.02	597	6.33	762	7.00	826	7.71	890	8.67	1040	9.55	1116	10.41	1193	10.98	1313	12.05	1399	13.12	1498
8'-0"	4.12	496	4.62	550	5.12	604	6.46	770	7.14	834	7.86	899	8.86	1051	9.73	1129	10.60	1205	11.20	1325	12.28	1412	13.36	1510
8'-3"	4.20	504	4.71	559	5.22	613	6.59	784	7.28	849	8.01	915	9.04	1069	9.92	1149	10.80	1228	11.42	1353	12.51	1440	13.60	1529
8'-6"	4.28	519	4.80	576	5.32	632	6.71	804	7.42	871	8.16	938	9.21	1107	10.10	1176	10.99	1257	11.64	1385	12.74	1474	13.84	1565
8'-9"	4.37	528	4.90	586	5.42	643	6.84	819	7.56	886	8.31	954	9.39	1119	10.29	1199	11.18	1280	11.87	1410	12.97	1500	14.08	1592
9'-0"	4.45	545	4.99	605	5.53	664	6.97	842	7.70	912	8.46	982	9.56	1148	10.47	1231	11.38	1313	12.09	1447	13.21	1539	14.32	1631
9'-3"	4.53	554	5.08	614	5.63	674	7.10	858	7.84	929	8.60	999	9.74	1169	10.66	1252	11.57	1335	12.31	1474	13.44	1563	14.56	1660
9'-6"	4.62	568	5.17	630	5.73	692	7.23	878	7.97	950	8.75	1022	9.92	1195	10.84	1280	11.77	1365	12.53	1505	13.67	1600	14.80	1696
10'-0"	4.78	582	5.36	645	5.93	708	7.49	900	8.11	974	9.05	1048	10.27	1227	11.21	1312	12.16	1399	12.98	1546	14.13	1642	15.29	1739

NOTE:  
FOR CONVENIENCE, DEPTHS OF INLETS SHOWN IN ABOVE TABLES ARE IN INCREMENTS OF 3 INCHES BUT ANY DEPTHS OTHER THAN THOSE SHOWN ABOVE MAY BE USED WHEREVER DEEMED NECESSARY. QUANTITIES FOR OTHER DEPTHS FALLING WITHIN THE LIMITS OF THE TABLE MAY BE FOUND BY INTERPOLATION.

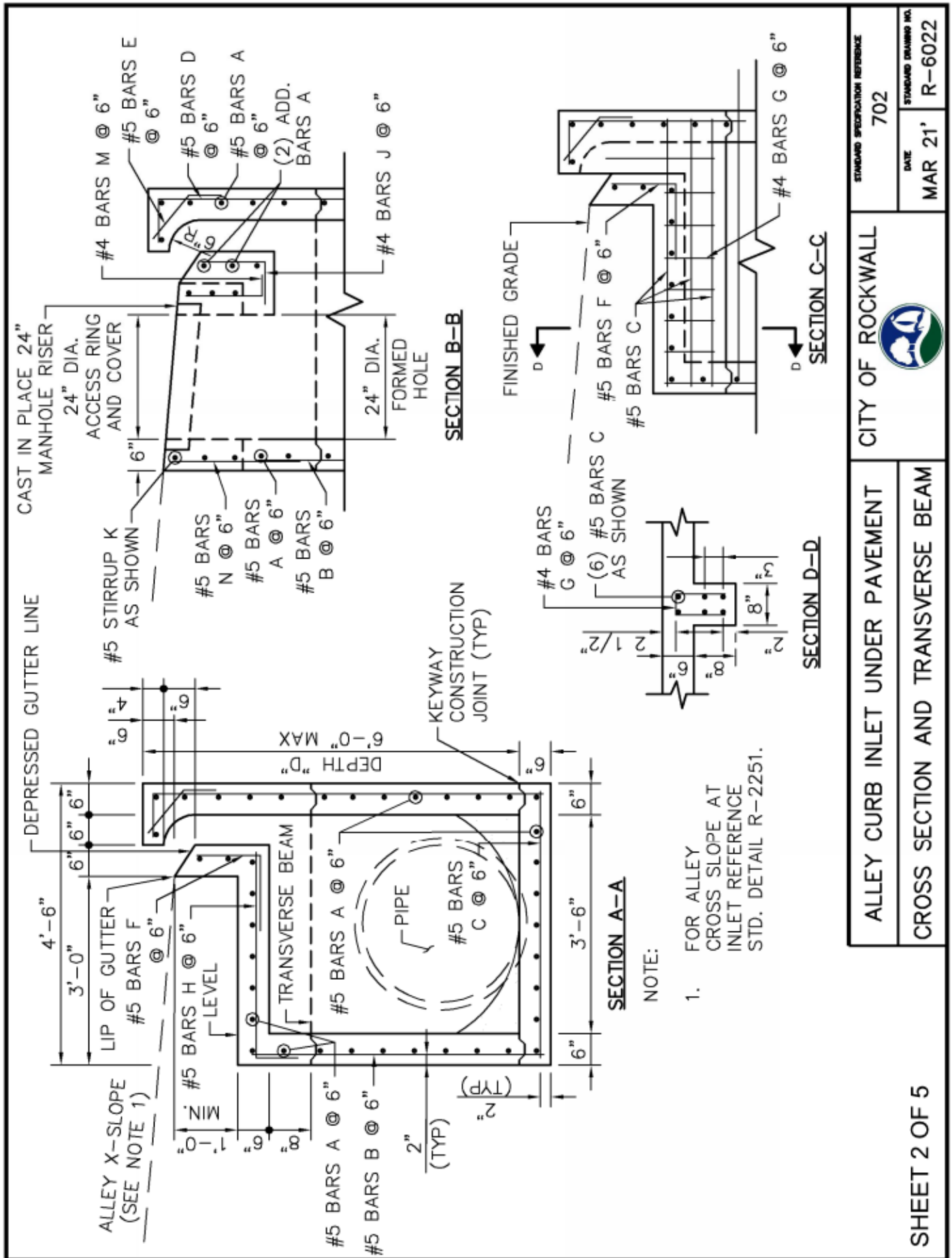
ALL CONCRETE STRUCTURES SHALL BE CLASS F (4200psi, MIN. 7.0 SACK CEMENT).  
NO FLY ASH IS ALLOWED IN CONCRETE STRUCTURES.

STANDARD DRAWING NO. <b>R-6020E</b>	CITY OF ROCKWALL 	STANDARD SPECIFICATION REFERENCE <b>702</b>
		DATE <b>Mar. 2018</b>
STANDARD DRAWING NO. <b>R-6020E</b>		





SHEET 1 OF 5	ALLEY CURB INLET UNDER PAVEMENT	CITY OF ROCKWALL	STANDARD SPECIFICATION REFERENCE
	5', 10', 15' OR 20' OPENING		702
		DATE	STANDARD DRAWING NO.
		MAR 21'	R-6022



ALLEY CURB INLET UNDER PAVEMENT CROSS SECTION AND TRANSVERSE BEAM	CITY OF ROCKWALL	STANDARD SPECIFICATION REFERENCE 702
		DATE MAR 21'
		STANDARD DRAWING NO. R-6022



- ① THICKNESS OF RDWY PAVEMENT PLUS FLEXBASE: IF LESS THAN 1'-0", INCREASE DEPTH OF FLEXBASE.
- ② SUBGRADE MATERIAL PER ROADWAY PAVEMENT DESIGN.
- ③ IF CONCRETE PAVEMENT IS PLACED DIRECTLY ON INLET DECK, APPLY APPROVED BOND BREAKER TO SURFACE OF INLET.

INLET ADJACENT TO PORTLAND CEMENT CONCRETE PAVEMENT

INLET ADJACENT TO HOT MIX ASPHALT PAVEMENT

GENERAL NOTES:

1. DESIGNED IN ACCORDANCE WITH AASHTO LRFD, 8TH EDITION, FOR THE FOLLOWING LOADS:  
DEAD LOAD: SELF-WEIGHT  
LIVE LOAD: HL-93  
EARTH PRESSURE: 100 PSF/FT
2. ALL REINFORCING STEEL SHALL BE GRADE 60.
3. ALL CONCRETE SHALL BE CLASS F (4,200 PSI, MIN. 7.0 SACK CEMENT). ALL EXPOSED CORNERS SHALL BE CHAMFERED 3/4".
4. ALL REINFORCING STEEL SHALL HAVE A MINIMUM COVER OF 2.0" TO THE CENTER OF THE BAR.
5. ALL BACK FILLING SHALL BE PERFORMED BY MECHANICAL TAMPING TO 95% STANDARD PROCTOR DENSITY.
6. NO FLY ASH IS ALLOWED IN CONCRETE STRUCTURES.
7. NO EARTH WALL FORMS, DOUBLE WALL FORMS TO BE USED.
8. FORMED CONCRETE ABOVE PIPE SHALL BE 0'-6" MIN. MAXIMUM PIPE SIZE - 30".

SHEET 3 OF 5

ALLEY CURB INLET UNDER PAVEMENT



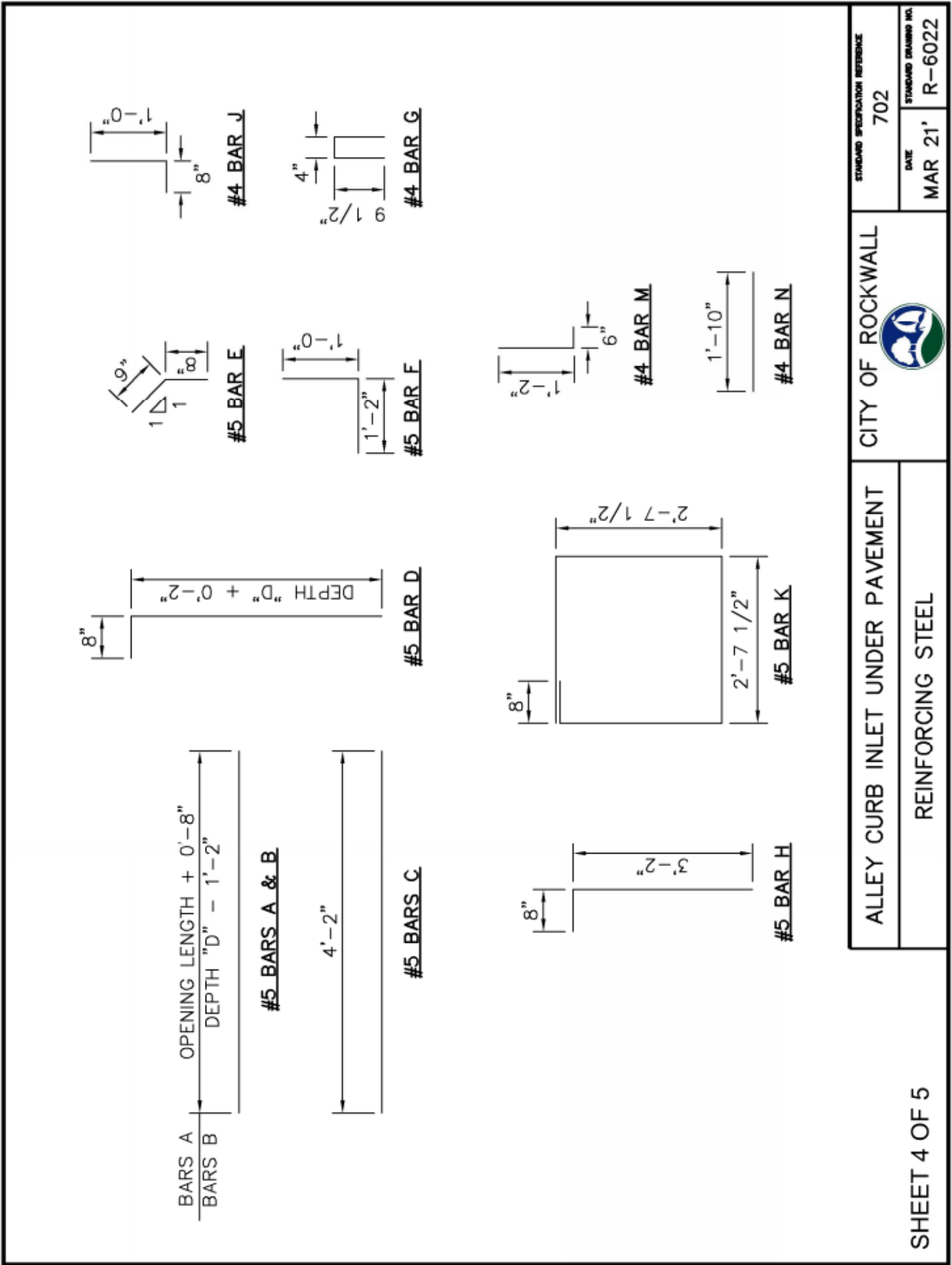
STANDARD SPECIFICATION REFERENCE  
702

DATE  
MAR 21'

STANDARD DRAWING NO.  
R-6022

CITY OF ROCKWALL

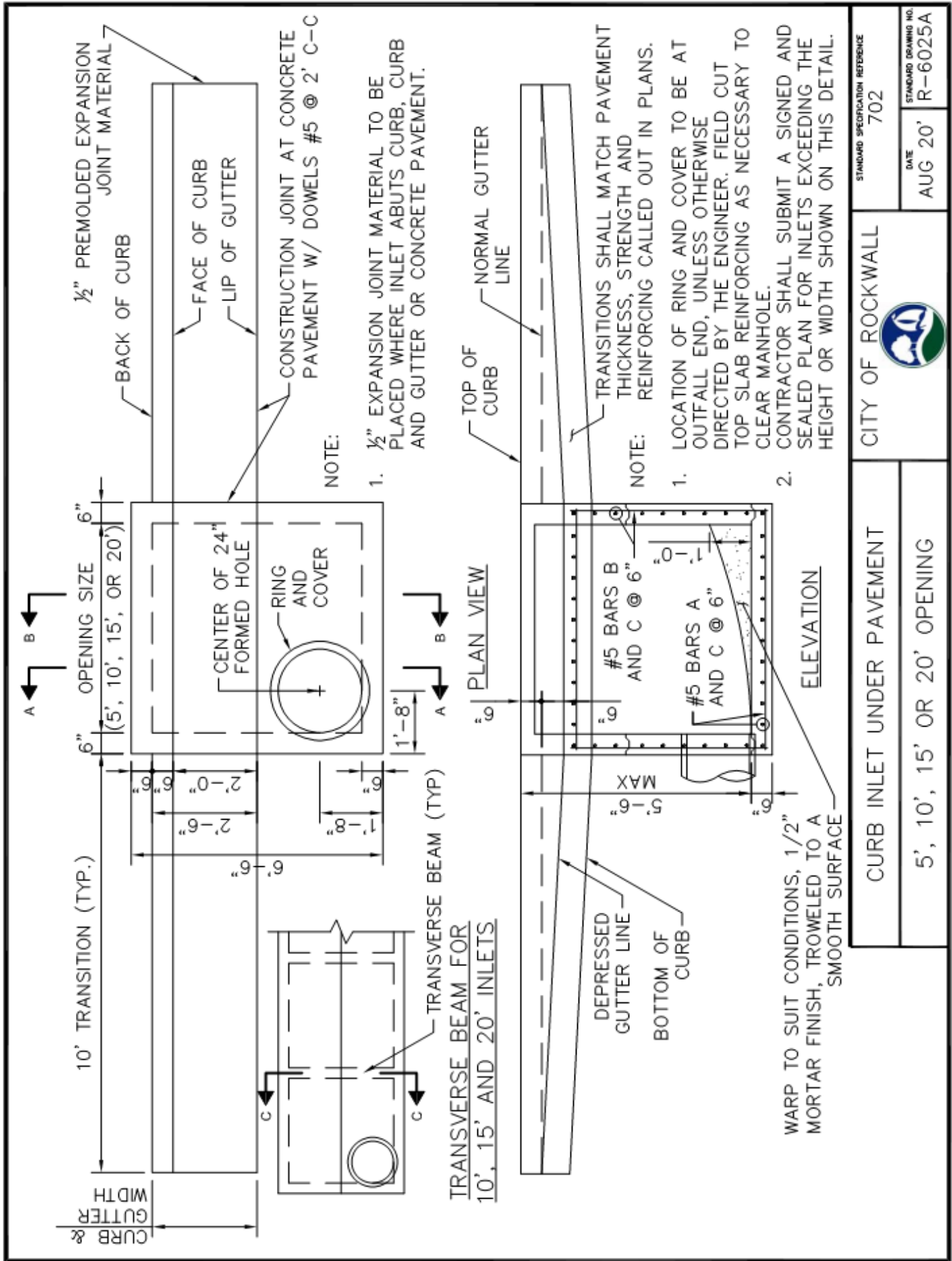
PVMT CONNECTION & GENERAL NOTES



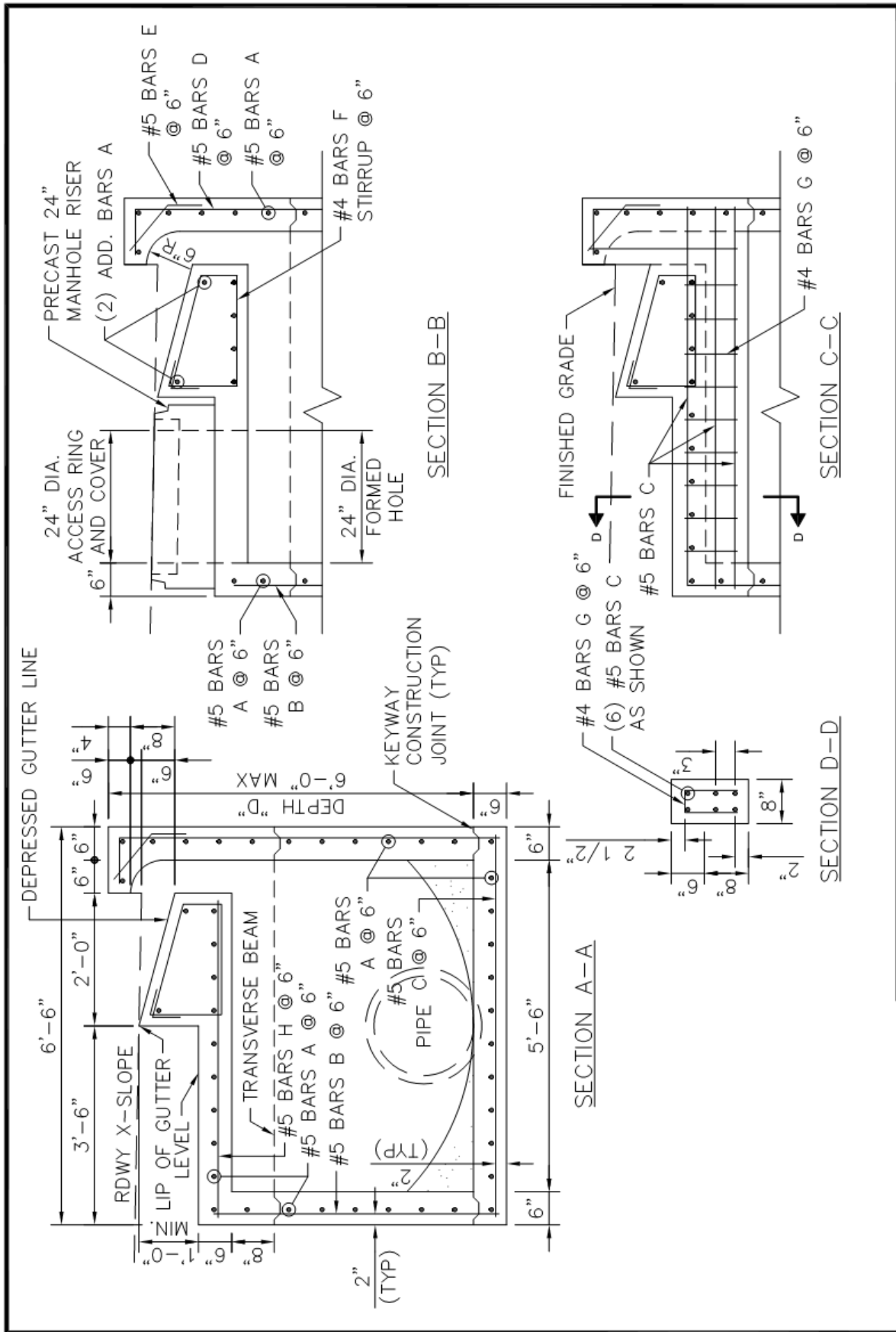
SHEET 4 OF 5

ALLEY CURB INLET UNDER PAVEMENT REINFORCING STEEL	CITY OF ROCKWALL	STANDARD SPECIFICATION REFERENCE 702
		DATE MAR 21'
		STANDARD DRAWING NO. R-6022

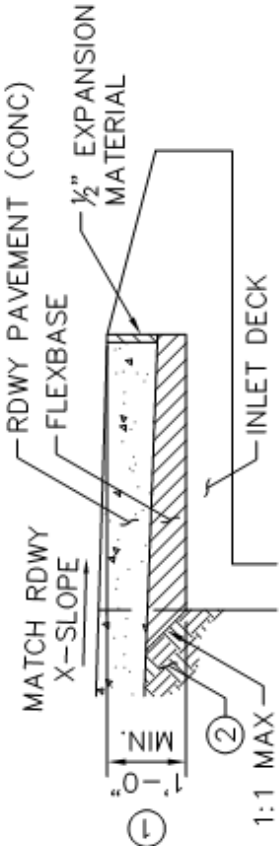
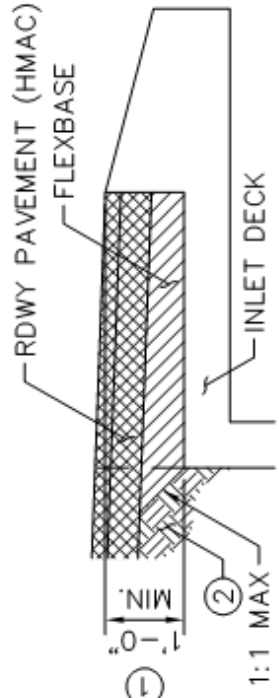




CITY OF ROCKWALL	STANDARD SPECIFICATION REFERENCE	702
	DATE	AUG 20'
CURB INLET UNDER PAVEMENT	STANDARD DRAWING NO.	R-6025A
5', 10', 15' OR 20' OPENING		



CURB INLET UNDER PAVEMENT CROSS SECTION AND TRANSVERSE BEAM	CITY OF ROCKWALL	STANDARD SPECIFICATION REFERENCE 702
		DATE AUG 20'
		STANDARD DRAWING NO. R-6025B



- ① THICKNESS OF RDWY PAVEMENT PLUS FLEXBASE: IF LESS THAN 1'-0", INCREASE DEPTH OF FLEXBASE.
- ② SUBGRADE MATERIAL PER ROADWAY PAVEMENT DESIGN.

INLET ADJACENT TO HOT MIX ASPHALT PAVEMENT

INLET ADJACENT TO PORTLAND CEMENT CONCRETE PAVEMENT

GENERAL NOTES:

1. DESIGNED IN ACCORDANCE WITH AASHTO LRFD, 8TH EDITION, FOR THE FOLLOWING LOADS:  
DEAD LOAD: SELF-WEIGHT  
LIVE LOAD: HL-93  
EARTH PRESSURE: 100 PSF/FT
2. ALL REINFORCING STEEL SHALL BE GRADE 60.
3. ALL CONCRETE SHALL BE CLASS F (4,200 PSI, MIN. 7.0 SACK CEMENT). ALL EXPOSED CORNERS SHALL BE CHAMFERED 3/4".
4. ALL REINFORCING STEEL SHALL HAVE A MINIMUM COVER OF 2.0" TO THE CENTER OF THE BAR.
5. 10'-0" OF EXISTING CURB AND GUTTER UPSTREAM AND 10'-0" OF EXISTING CURB AND GUTTER DOWNSTREAM SHALL BE REMOVED AND REPOURED INTEGRALLY WITH EACH INLET.
6. ALL BACK FILLING SHALL BE PERFORMED BY MECHANICAL TAMPING TO 95% STANDARD PROCTOR DENSITY.
7. NO FLY ASH IS ALLOWED IN CONCRETE STRUCTURES.
8. NO EARTH WALL FORMS, DOUBLE WALL FORMS TO BE USED.
9. FORMED CONCRETE ABOVE PIPE SHALL BE 0'-6" MIN. MAXIMUM PIPE SIZE - 30".

CURB INLET UNDER PAVEMENT PVMT CONNECTION & GENERAL NOTES	 CITY OF ROCKWALL	STANDARD SPECIFICATION REFERENCE 702
	DATE AUG 20'	STANDARD DRAWING NO. R-6025C



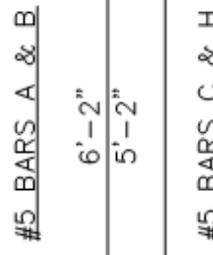
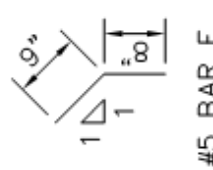
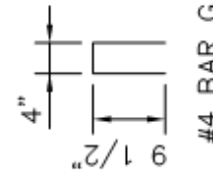
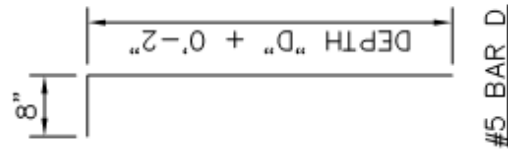
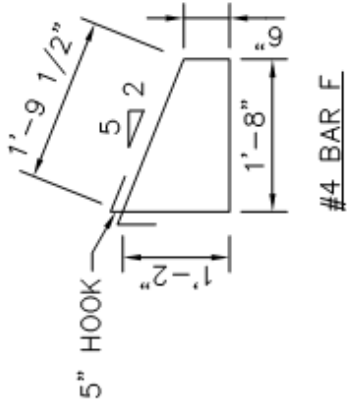


BILL OF REINFORCING STEEL

DEPTH "D"	OPENING LENGTH = 5 FT								OPENING LENGTH = 10 FT							
	A	B	C	D	E	F	G	H	A	B	C	D	E	F	G	H
4'-0"	37	34	22	12	12	10	-	12	37	45	38	23	23	21	10	20
4'-6"	39	"	24	"	"	"	"	"	39	"	40	"	"	"	"	"
5'-0"	41	"	26	"	"	"	"	"	41	"	42	"	"	"	"	"
5'-6"	43	"	28	"	"	"	"	"	43	"	44	"	"	"	"	"
6'-0"	45	"	30	"	"	"	"	"	45	"	46	"	"	"	"	"

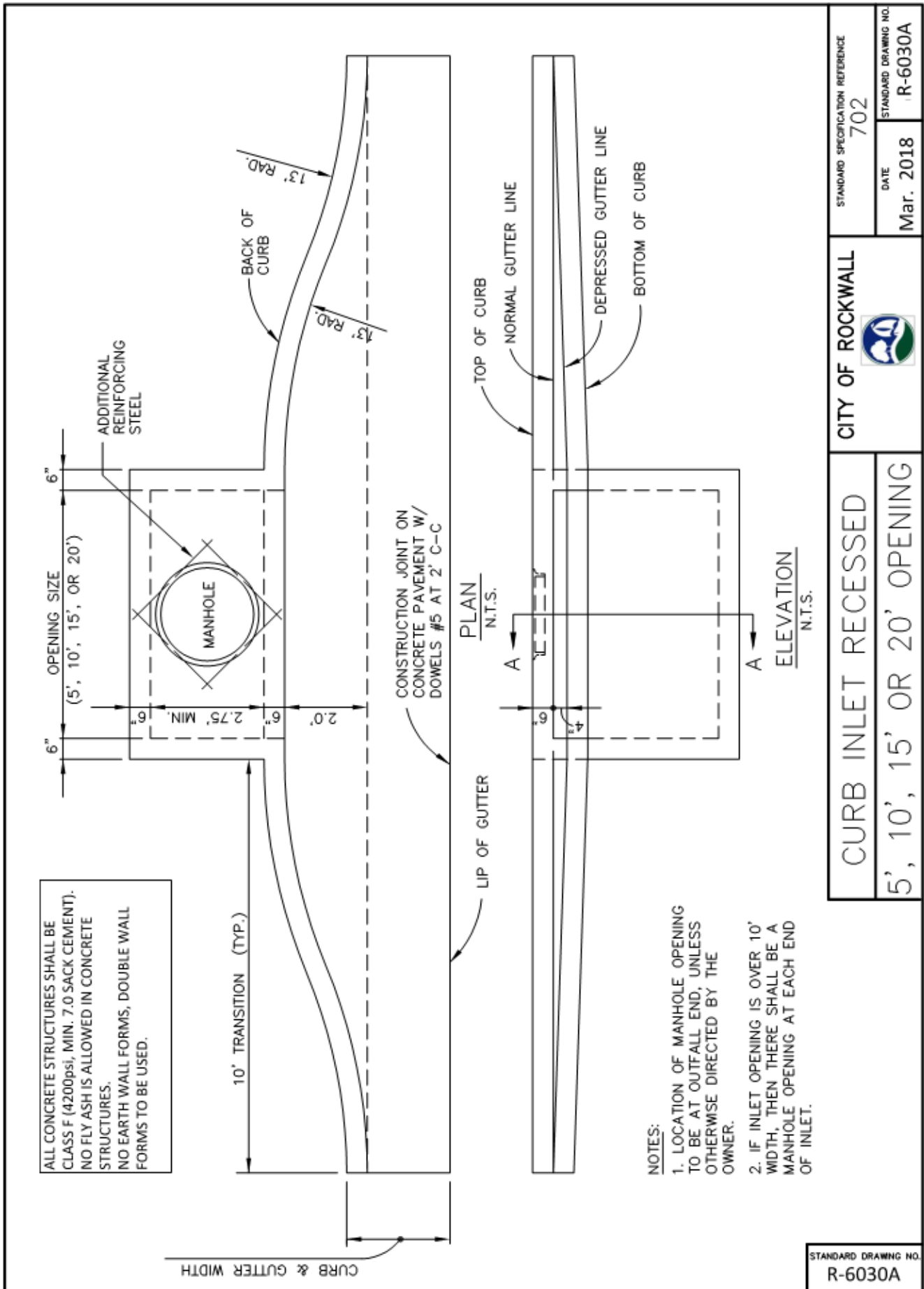
DEPTH "D"	OPENING LENGTH = 15 FT								OPENING LENGTH = 20 FT							
	A	B	C	D	E	F	G	H	A	B	C	D	E	F	G	H
4'-0"	37	56	56	34	34	32	20	30	37	67	73	45	45	43	30	40
4'-6"	39	"	58	"	"	"	"	"	39	"	75	"	"	"	"	"
5'-0"	41	"	60	"	"	"	"	"	41	"	77	"	"	"	"	"
5'-6"	43	"	62	"	"	"	"	"	43	"	79	"	"	"	"	"
6'-0"	45	"	64	"	"	"	"	"	45	"	81	"	"	"	"	"



CITY OF ROCKWALL	STANDARD SPECIFICATION REFERENCE 702
	DATE AUG 20' STANDARD DRAWING NO. R-6025D

CURB INLET UNDER PAVEMENT  
BILL OF REINFORCING STEEL





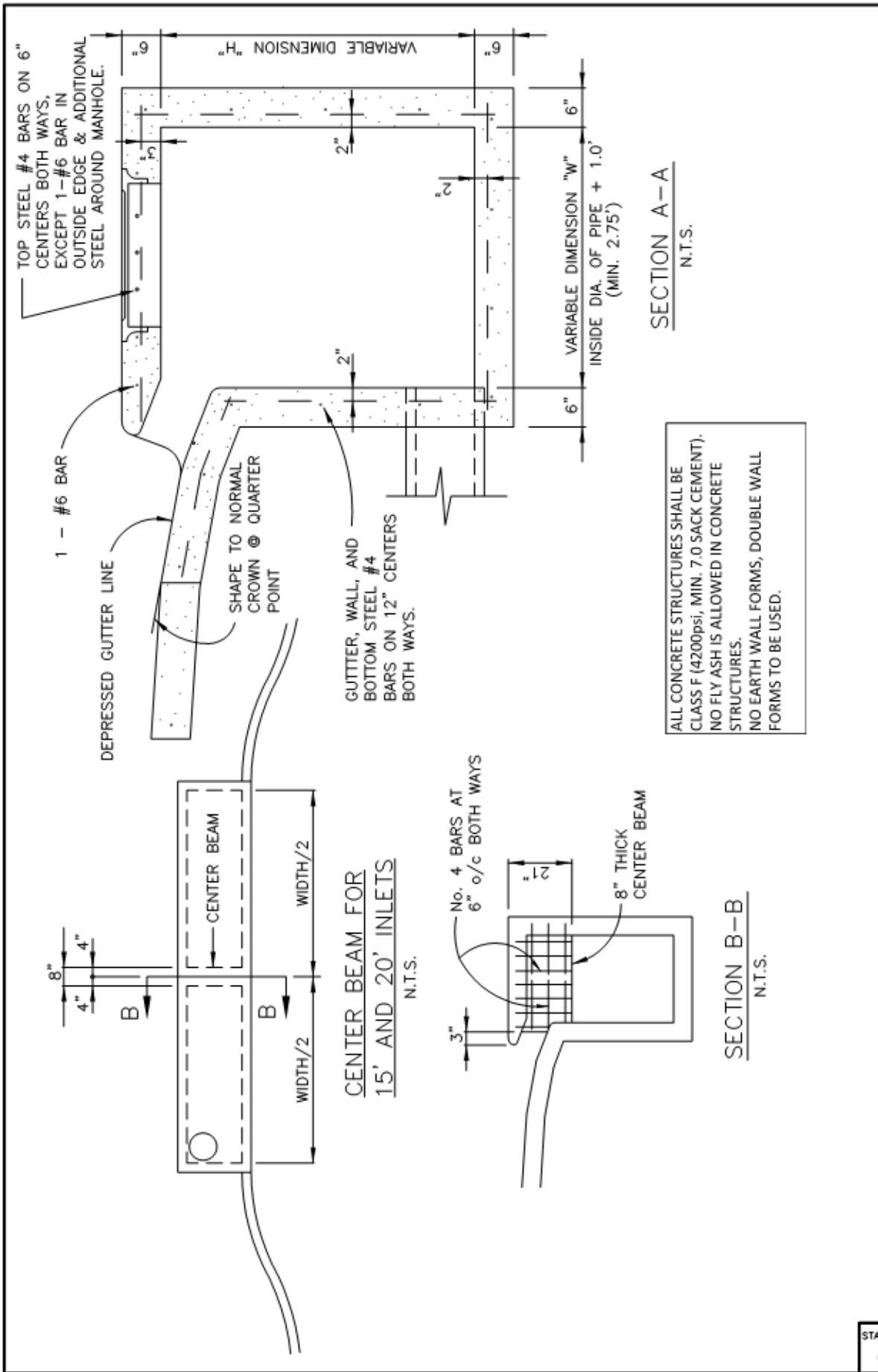
STANDARD SPECIFICATION REFERENCE	702
DATE	Mar. 2018
STANDARD DRAWING NO.	R-6030A

CITY OF ROCKWALL

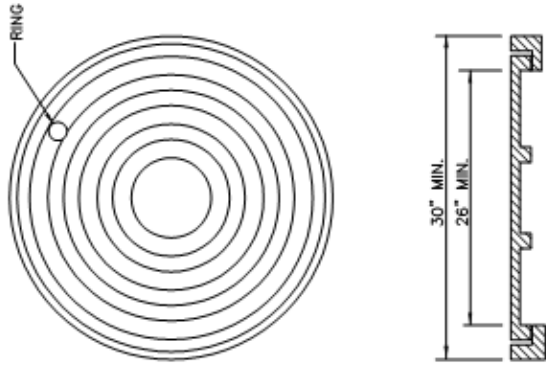
CURB INLET RECESSED

5', 10', 15' OR 20' OPENING

STANDARD DRAWING NO.	R-6030A
----------------------	---------



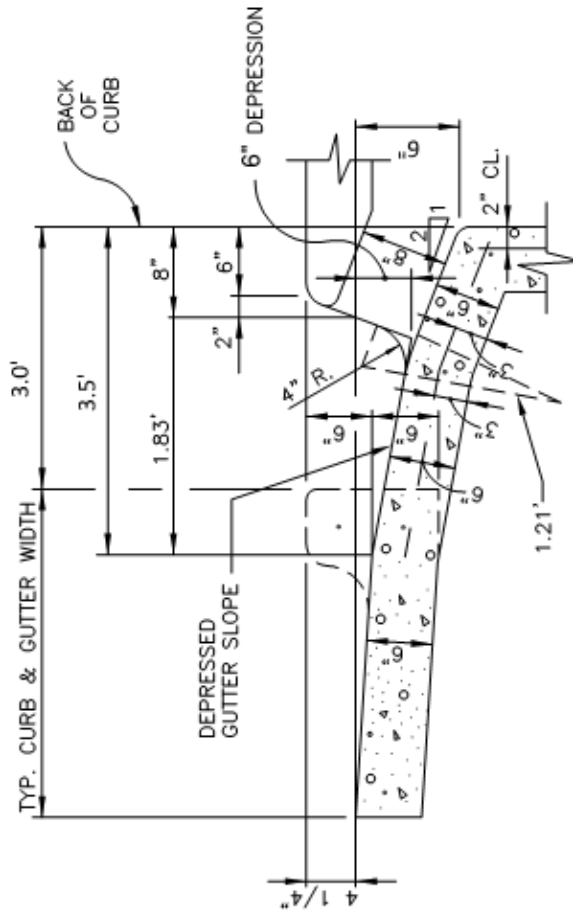
CITY OF ROCKWALL		STANDARD SPECIFICATION REFERENCE
		702
		STANDARD DRAWING NO.
CURB INLET RECESSED		DATE
CROSS SECTION & CENTER BEAM		Mar. 2018
		STANDARD DRAWING NO.
		R-6030B



MANHOLE FRAME & COVER

N.T.S.

INLET LID OF BE LOCKING



ALL CONCRETE STRUCTURES SHALL BE CLASS F (4200psi, MIN. 7.0 SACK CEMENT). NO FLY ASH IS ALLOWED IN CONCRETE STRUCTURES.

INLET THROAT

N.T.S.

STANDARD SPECIFICATION REFERENCE	702
DATE	Mar. 2018
STANDARD DRAWING NO.	R-6030C

CITY OF ROCKWALL



CURB INLET RECESSED  
INLET THROAT & M.H. FRAME & COVER

STANDARD DRAWING NO.  
R-6030C



GENERAL NOTES:

1. IN GENERAL, REINFORCING STEEL SHALL BE #4 BARS ON 12" CENTERS BOTH WAYS FOR GUTTER, BOTTOM SLAB ENDS, FRONT AND BACK WALLS, AND #4 BARS ON 6" CENTERS BOTH WAYS FOR TOP SLAB. AN ADDITIONAL #6 BAR SHALL BE PLACED IN THE FRONT EDGE OF THE TOP SLAB IN THE INLETS AND ADDITIONAL REINFORCING STEEL SHALL BE PLACED AROUND MANHOLES AS SHOWN.
2. ALL REINFORCING STEEL SHALL BE GRADE 60.
3. ALL CONCRETE STRUCTURES SHALL BE CLASS F (4200psi, MIN. 7.0 SACK CEMENT). ALL EXPOSED CORNERS SHALL BE CHAMFERED 3/4".
4. ALL REINFORCING STEEL SHALL HAVE A MINIMUM COVER OF 2" TO THE CENTERS OF THE BARS.
5. 10'-0" OF EXISTING CURB AND GUTTER UPSTREAM AND 10'-0" OF EXISTING CURB AND GUTTER DOWNSTREAM SHALL BE REMOVED AND REPOURED INTEGRALLY WITH EACH INLET.
6. ALL BACK FILLING SHALL BE PERFORMED BY MECHANICAL TAMPING TO 95% STANDARD PROCTOR DENSITY.
7. NO FLY ASH IS ALLOWED IN CONCRETE STRUCTURES.

STANDARD SPECIFICATION REFERENCE	
702	
DATE	STANDARD DRAWING NO.
Mar. 2018	R-6030D

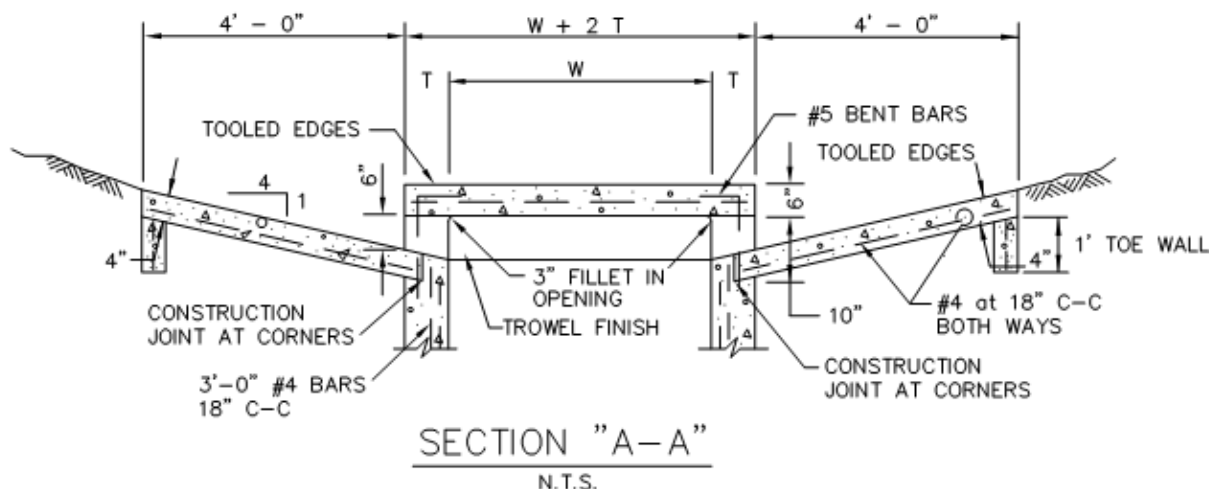
CITY OF ROCKWALL



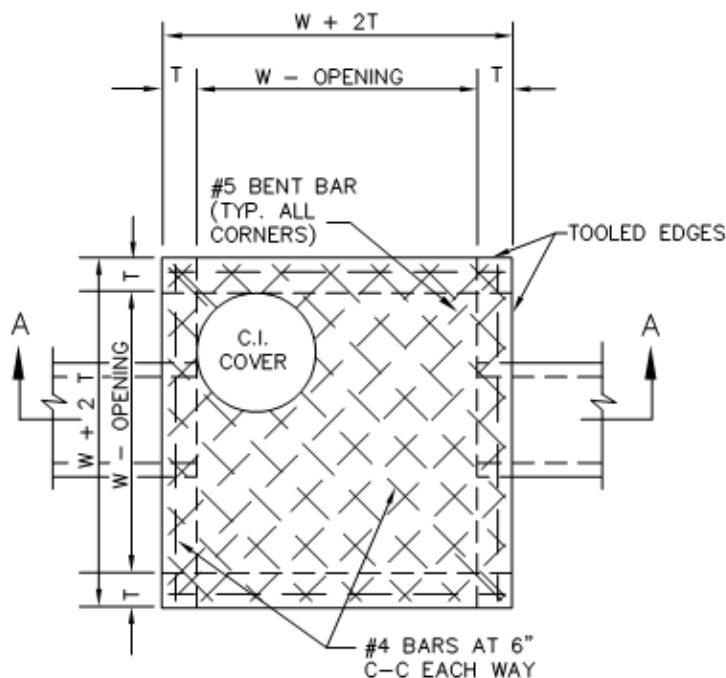
CURB INLET RECESSED

GENERAL NOTES

STANDARD DRAWING NO.  
R-6030D



SECTION "A-A"  
N.T.S.



PLAN OF TOP SLAB  
N.T.S.

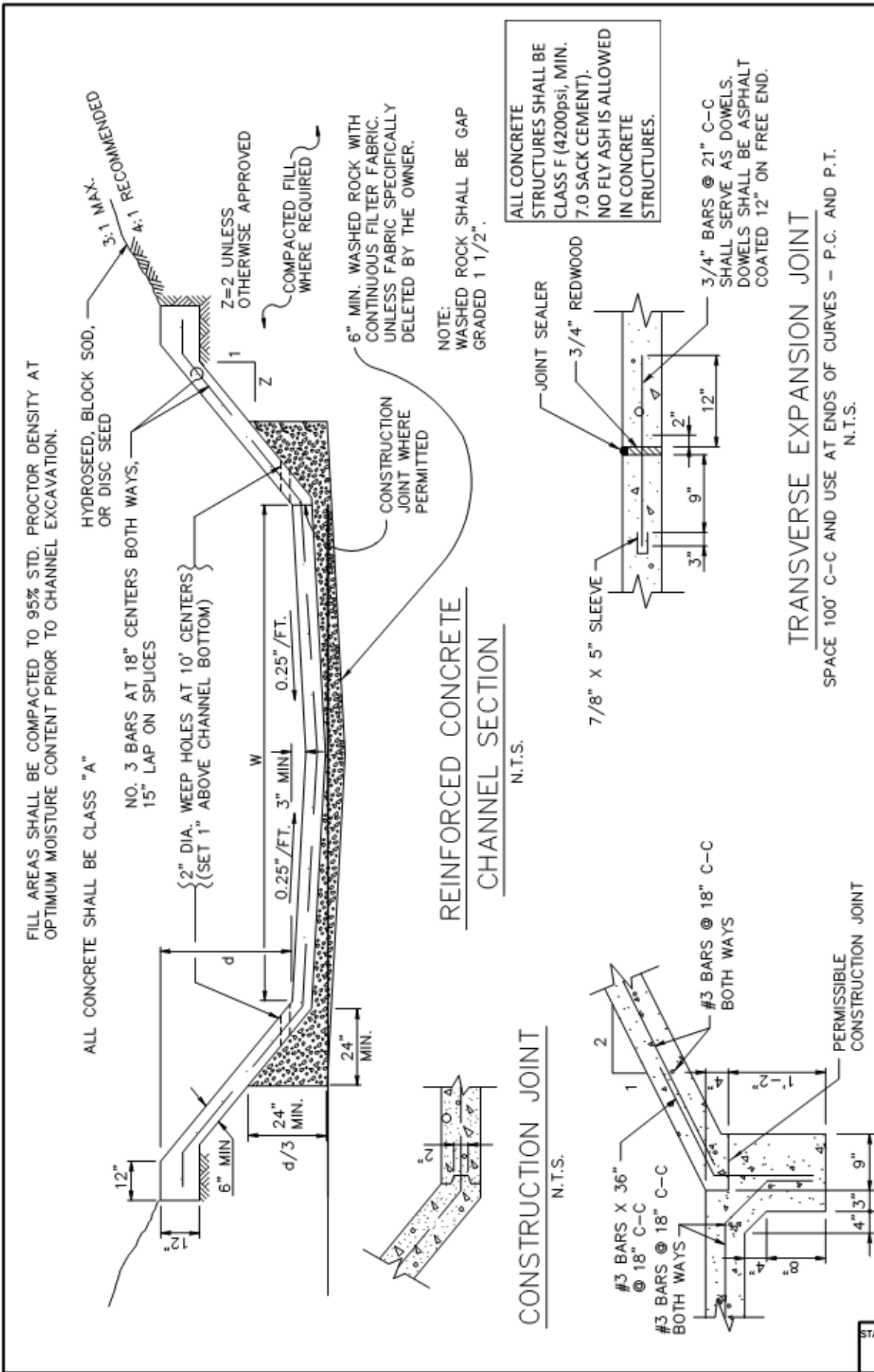
ALL CONCRETE STRUCTURES SHALL BE CLASS F (4200psi, MIN. 7.0 SACK CEMENT). NO FLY ASH IS ALLOWED IN CONCRETE STRUCTURES. NO EARTH WALL FORMS, DOUBLE WALL FORMS TO BE USED.

INLET SIZE	T	W
2' SQUARE	7"	2'-0"
4' SQUARE	7"	4'-0"
5' SQUARE	8"	5'-0"
6' SQUARE	9"	6'-0"

**NOTES:**

1. MATERIAL AND WORKMANSHIP SHALL CONFORM WITH THE REQUIREMENTS OF NCTCOG STANDARD SPECIFICATIONS FOR STANDARD CONCRETE MANHOLES. MINIMUM CLASS "A" CONCRETE.
2. LAYERS OF REINFORCING STEEL NEAREST THE INTERIOR AND EXTERIOR SURFACES SHALL HAVE A COVER OF 2" TO THE CENTER OF BARS, UNLESS OTHERWISE NOTED.
3. FOR DETAILS OF REINFORCING OF LOWER PORTIONS OF INLET SEE APPROPRIATE SQUARE MANHOLE DETAILS.
4. DEPTH OF DROP INLET FROM FINISHED GRADE TO FLOW LINE OF INLET IS VARIABLE. APPROXIMATE DEPTH WILL BE SHOWN ON PLANS AT LOCATION OF INLET.
5. ALL STANDARD DROP INLETS SHALL HAVE ONE OPENING ON EACH SIDE UNLESS OTHERWISE SHOWN ON PLANS.
6. DECK MAY BE REINFORCED SAME AS 4' SQUARE MANHOLE.

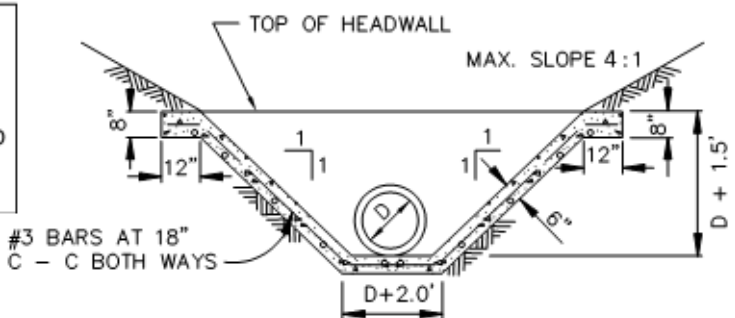
DROP INLET	CITY OF ROCKWALL	STANDARD SPECIFICATION REFERENCE <b>702</b>
2', 4', 5' OR 6' SQUARE		DATE <b>Mar. 2018</b> STANDARD DRAWING NO. <b>R-6040</b>



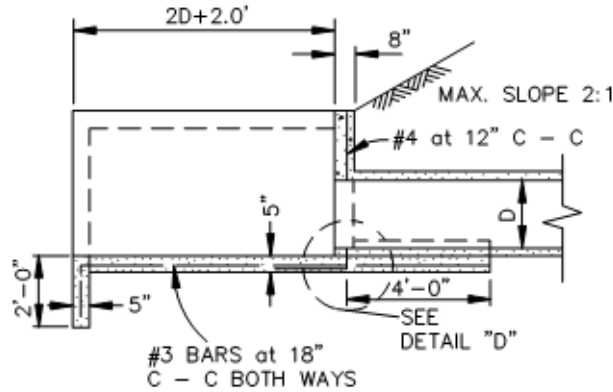
STANDARD DRAWING NO. <b>R-6050</b>	CITY OF ROCKWALL	STANDARD SPECIFICATION REFERENCE <b>803.3</b>
		DATE <b>Mar. 2018</b>
FULL CHANNEL LINING CONCRETE REINFORCED		STANDARD DRAWING NO. <b>R-6050</b>
ALTERNATE CONSTRUCTION JOINT N.T.S.		



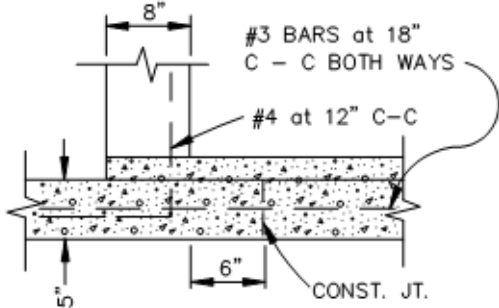
ALL CONCRETE STRUCTURES SHALL BE CLASS F (4200psi, MIN. 7.0 SACK CEMENT), NO FLY ASH IS ALLOWED IN CONCRETE STRUCTURES.



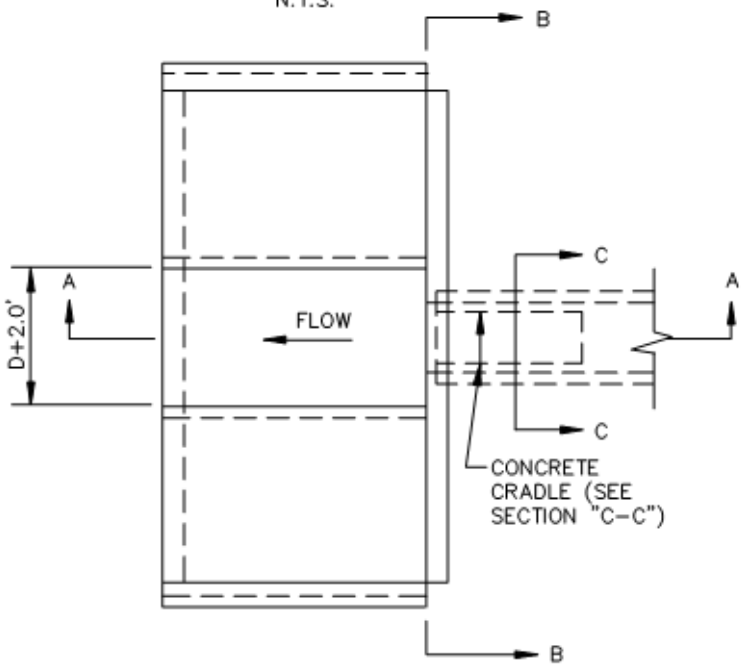
SECTION "B-B"  
N.T.S.



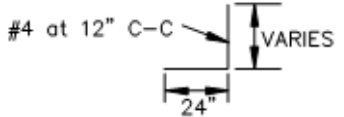
SECTION "A-A"  
N.T.S.



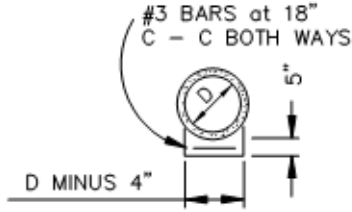
DETAIL "D"  
N.T.S.



PLAN  
N.T.S.



BAR DETAIL  
N.T.S.



SECTION "C-C"  
N.T.S.

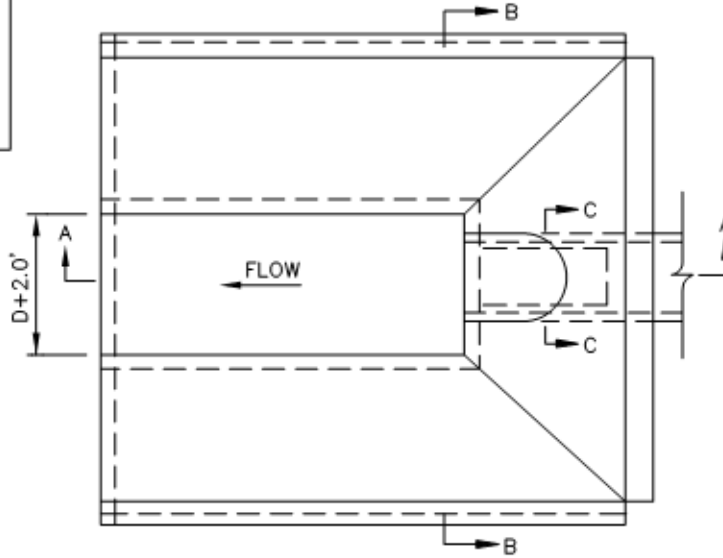
NOTE:  
CONCRETE SHALL BE CLASS "A"

CONCRETE APRON VERTICAL HEADWALL	CITY OF ROCKWALL 	STANDARD SPECIFICATION REFERENCE 803.3	
		DATE Mar. 2018	STANDARD DRAWING NO. R-6060

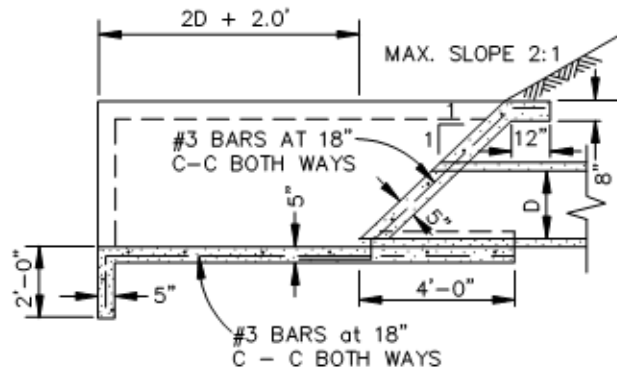




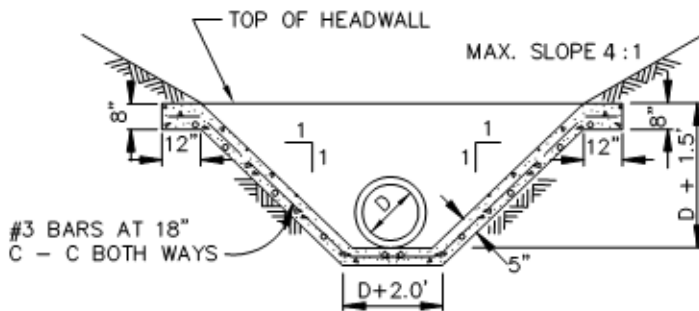
ALL CONCRETE STRUCTURES SHALL BE CLASS F (4200psi, MIN. 7.0 SACK CEMENT). NO FLY ASH IS ALLOWED IN CONCRETE STRUCTURES.



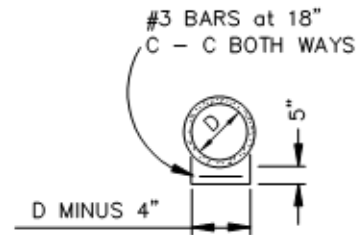
PLAN  
N.T.S.



SECTION A-A  
N.T.S.



SECTION B-B  
N.T.S.



SECTION C-C  
N.T.S.

NOTE:  
CONCRETE SHALL BE CLASS "A".

CONCRETE APRON  
SLOPING HEADWALL

CITY OF ROCKWALL



STANDARD SPECIFICATION REFERENCE

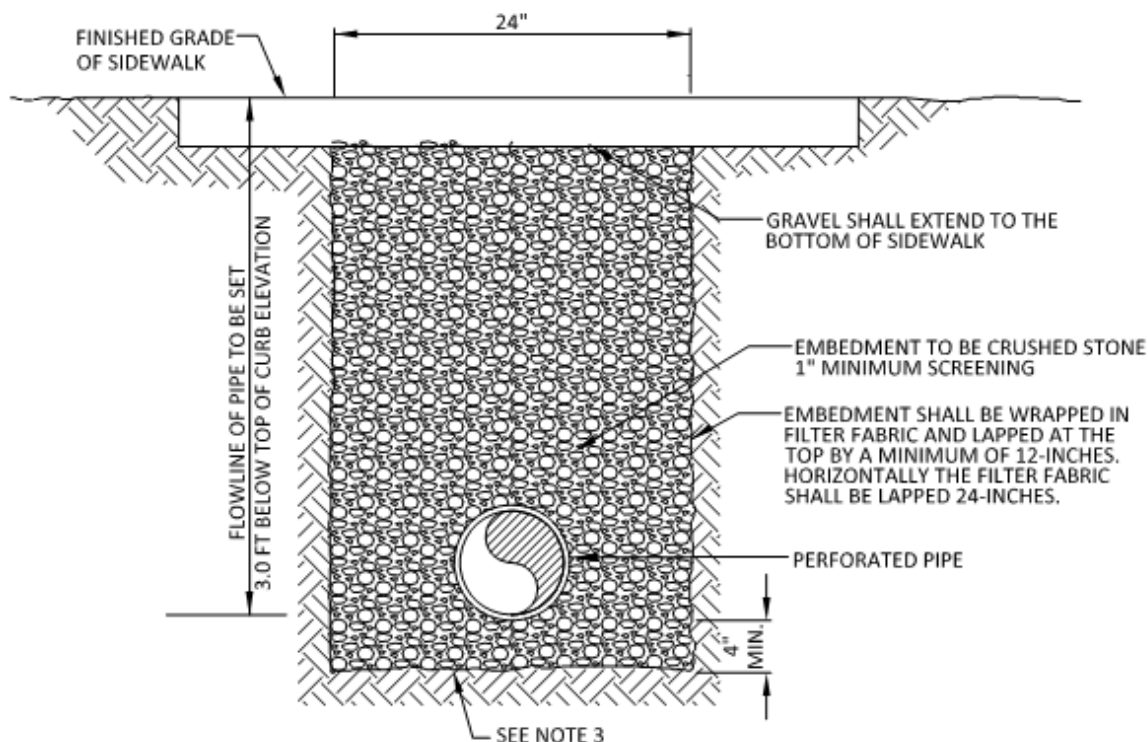
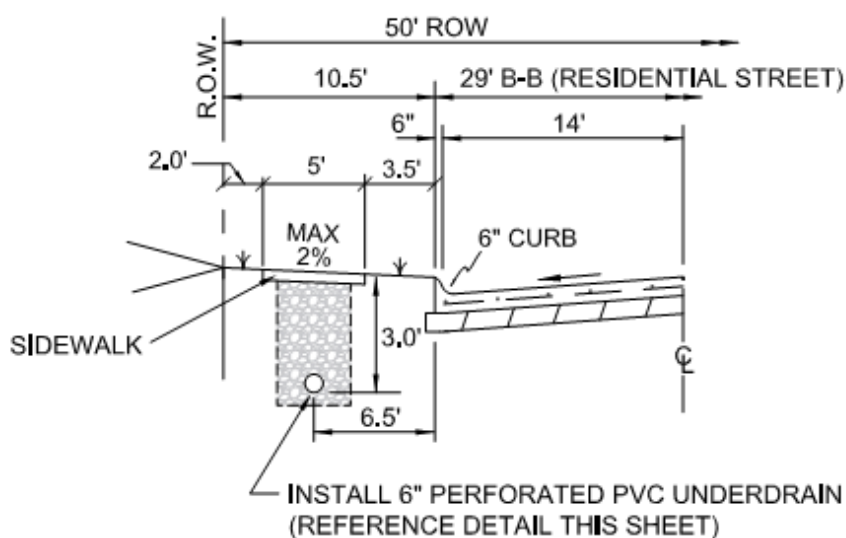
803.3

DATE

Mar. 2018

STANDARD DRAWING NO.

R-6070



## NOTES:

1. THE UNDER DRAIN/FRENCH DRAIN SYSTEM SHALL BE PVC 6" DIAMETER TYPE PS-46 PVC PIPE OR APPROVED EQUAL. THE PIPE SHALL MEET ALL CURRENT ASTM F758 REQUIREMENTS AND SHALL HAVE GASKET TYPE JOINTS. THE PERFORATED AND CONDUCTING PIPES SHALL BE WHITE IN COLOR.
2. CLEANOUTS SHALL BE INSTALLED AT LOCATIONS AS CALLED OUT IN THE TABLE PROVIDED. CLEANOUTS SHALL BE A 6"X6" WYE WITH BASS & HAYS 339 CLEANOUT BOOT AND 399 UNDERDRAIN LID.
3. PLACE A SINGLE LAYER OF FILTER FABRIC WITH A LAP OVER THE PVC PIPE, BETWEEN THE EMBEDMENT AND INITIAL BACKFILL MATERIAL. THE FILTER FABRIC SHALL BE A NON-WOVEN INERT MATERIAL GREATER THAN OR EQUAL TO "MIRAFI 140N" AS MANUFACTURED BY THE MIRAFI GEOTEXTILE FABRICS COMPANY.

UNDERDRAIN/FRENCH DRAIN DETAIL

CITY OF ROCKWALL

UNDER SIDEWALK - RESIDENTIAL STREET

DATE  
MAR. 2021DRAWING NO.  
R-6080

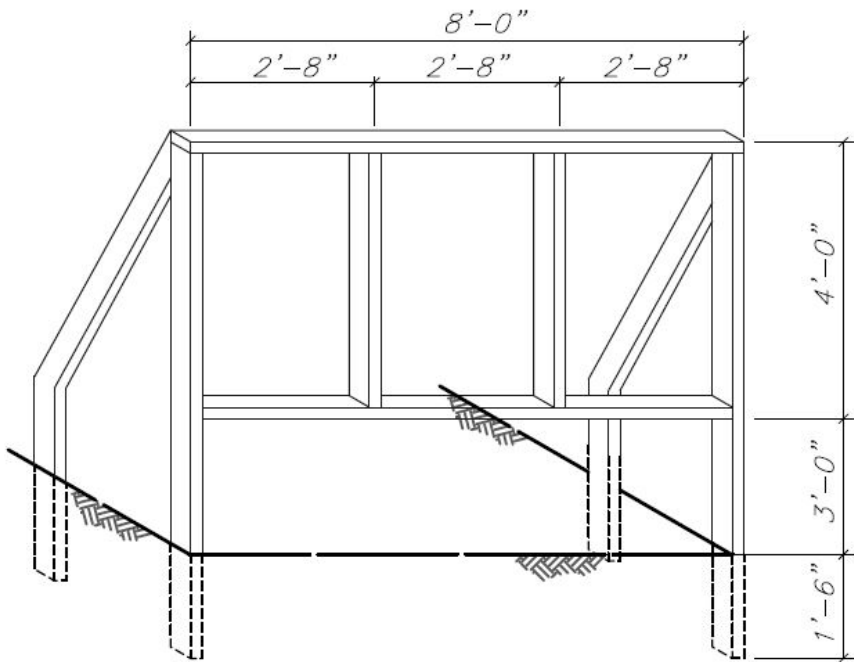
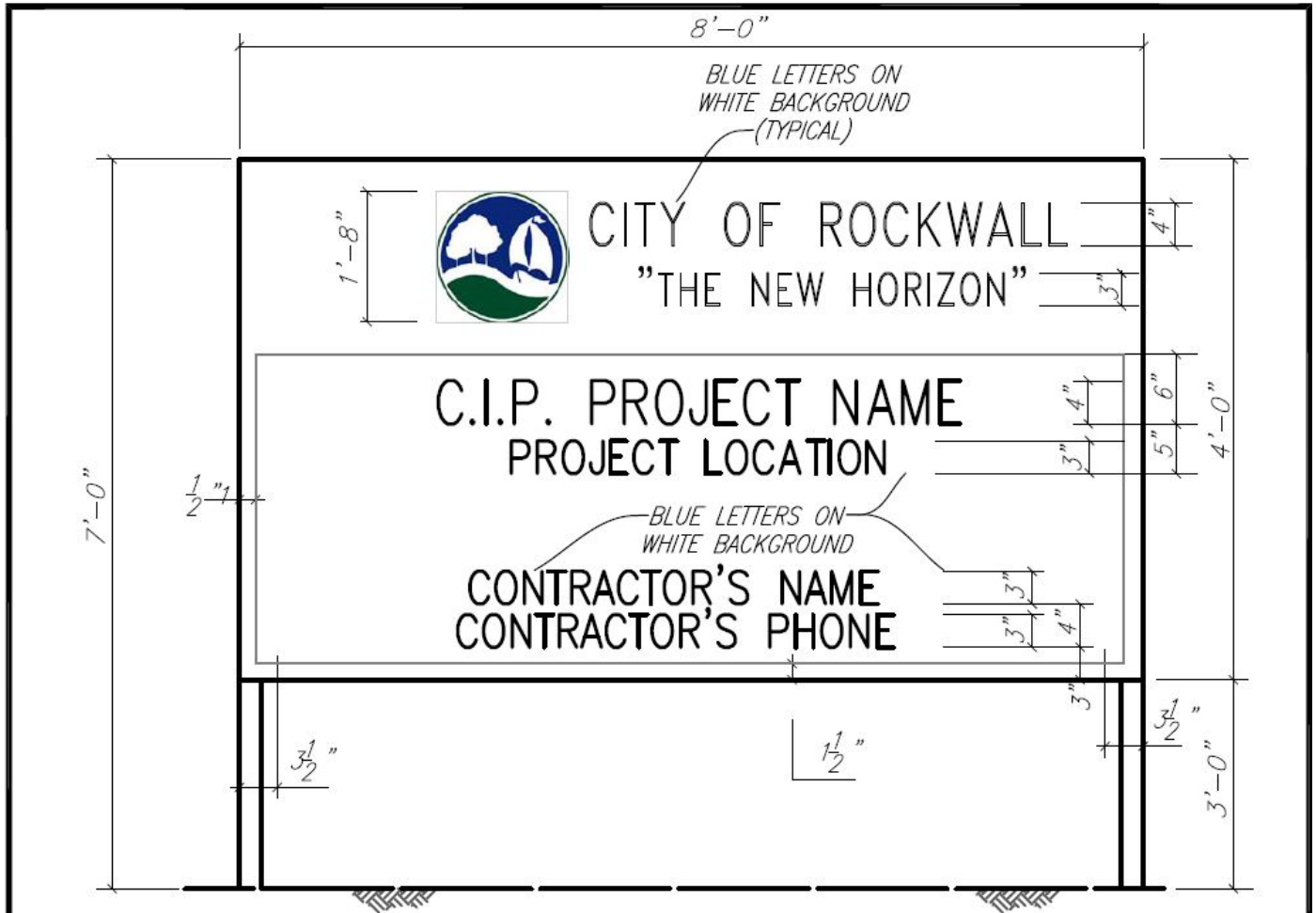


SECTION 8.07 | DIVISION 7000. ROCKWALL MISCELLANEOUS DETAILS

This Division 7000 is to be added to the NCTCOG's Standard Drawings for Public Works Construction Standards. Division 7000 contains miscellaneous standard details added by the City. The following Table 8.7 contains a list of the miscellaneous standards being added.

TABLE 8.7: DIVISION 7000. ROCKWALL MISCELLANEOUS DETAILS

DRAWING NO.	DESCRIPTION
R-7010	MISCELLANEOUS DETAILS – CONSTRUCTION SIGN DETAIL
R-7020	MISCELLANEOUS DETAILS – RESIDENTIAL LOT TYPICAL WALL & SWALE DETAIL




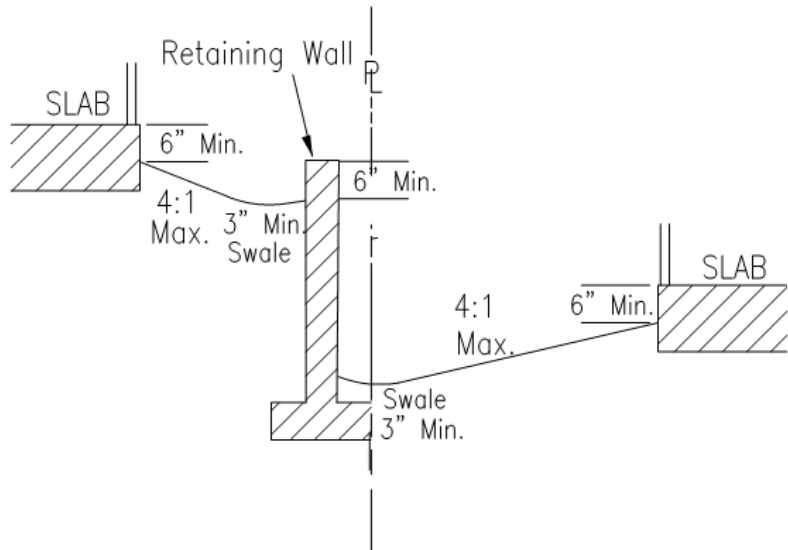
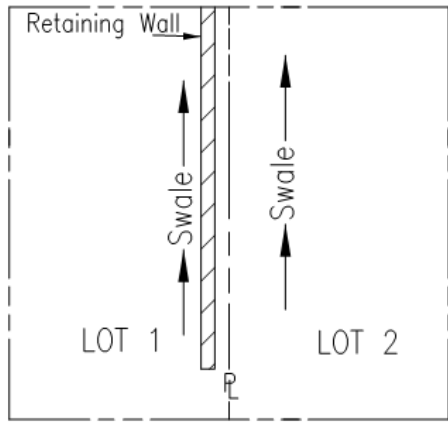
**SIGN FRAME ELEVATION**

**SIGN PANEL** 3/4" EXTERIOR PLYWOOD  
PAINT AS SHOWN ON DETAIL ABOVE

**FRAME** 2"x4" STOCK FRAME TO BE  
PAINTED WHITE

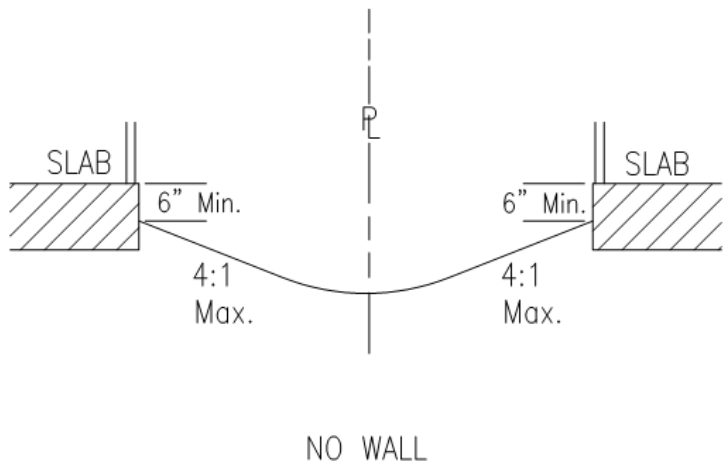
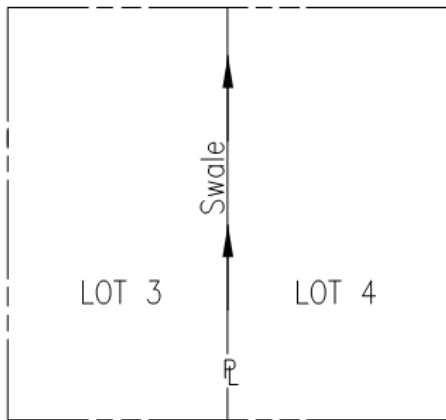
ALL PAINT TO BE "EXTERIOR GRADE"

MISCELLANEOUS DETAILS	CITY OF ROCKWALL		
CONSTRUCTION SIGN DETAIL		DATE AUG. '15	DRAWING NO. R-7010



**NOTE:**

No Retaining Walls including the footing shall be placed in the right-of-way, easements, or overlapping property lines.



MISCELLANEOUS DETAILS

CITY OF ROCKWALL

RESIDENTIAL LOT  
TYPICAL WALL & SWALE DETAIL



DATE AUG. '22	DRAWING NO. R-7020
------------------	-----------------------





APPENDIX A | ENGINEERING PLAN REVIEW CHECKLIST



## ENGINEERING STANDARDS OF DESIGN AND CONSTRUCTION MANUAL | ENGINEERING PLAN REVIEW CHECKLIST

### ADMINISTRATIVE ITEMS

NOTES:  = COMPLETE |  = DEFICIENT |  = N/A

- ENGINEERING PLAN SUBMISSION APPLICATION WITH SUBMITTAL CHECKLIST
- ENGINEERING-PLAN REVIEW CHECKLIST
- FOUR COMPLETE COPIES OF ENGINEERING PLANS INITIAL SUBMITTAL; THREE COMPLETE COPIES OF ENGINEERING PLANS RE-SUBMITTAL; TWO ADDITIONAL SETS EACH SUBMITTAL IS PROPOSED LIFT STATION.
- MARKUPS FROM PREVIOUS SUBMITTALS, IF SUBSEQUENT SUBMITTAL
- ANNOTATED REVIEW COMMENTS, IF APPLICABLE
- TWO COPIES OF ANY STUDY OR REPORT COMPLETED IN SUPPORT OF THE PROJECT
- SUBMISSION OF REQUIRED FIRE FLOWS FORM TO FIRE MARSHAL
- SUBMISSION OF FIRE HYDRANT FLOW FORM TO FIRE MARSHAL
- FLOODPLAIN ADMINISTRATOR DEVELOPMENT PERMIT APPLICATION
- STORM DRAINAGE MANAGEMENT PLAN
- TXDOT PRELIMINARY LETTER OF APPROVAL FOR DRIVE APPROACH CONNECTIONS
- TXDOT PERMITS OBTAINED
- FRANCHISED UTILITY APPROVAL OBTAINED (SPECIFY)
- OTHER AGENCY OR LAND OWNER APPROVAL OBTAINED (SPECIFY)
- CORPS OF ENGINEERS (COE) WETLAND PERMIT OBTAINED (IF APPLICABLE) OR LETTER OF DETERMINATION
- FEDERAL EMERGENCY MANAGEMENT AGENCY (FEMA) LETTER OF MAP REVISION (LOMR)
- OTHER AGREEMENTS (EXPLAIN)

### STUDIES (IF REQUIRED)

NOTES:  = COMPLETE |  = DEFICIENT |  = N/A

- GEOTECHNICAL REPORT
- FEDERAL EMERGENCY MANAGEMENT AGENCY (FEMA) LETTER OF MAP REVISION (LOMR) FLOOD STUDY
- WETLAND AND WATER OF U.S. DETERMINATION
- LIFT STATION REPORT
- HYDRAULIC STUDY SUBMITTED
- WATER STUDY SUBMITTED
- SANITARY SEWER CAPACITY STUDY SUBMITTED
- TRAFFIC IMPACT ANALYSIS
- FLOOD STUDY (100 YEAR-FULLY DEVELOPED) (LOCAL OR FEMA)
- SIGHT VISIBILITY DETERMINATION FOR EASEMENTS

### ALL SHEETS

NOTES:  = COMPLETE |  = DEFICIENT |  = N/A

- SHEET SIZE 24" X 36"
- TITLE BLOCK WITH SUBDIVISION NAME, PROJECT NAME AND SHEET DESCRIPTION
- REVISION BLOCK - FILLED OUT
- NORTH ARROW
- VERTICAL AND HORIZONTAL SCALE LISTED AND ACCURATE





- BENCHMARKS LISTED AND DESCRIBED
- LEGEND OF ALL DRAWING SYMBOLS AND LINE TYPES USED
- ENGINEER'S SEAL, SIGNATURE AND DATE PER TEXAS ENGINEERING PRACTICES ACT
- RESPONSIBILITY NOTE REQUIRED ON ALL SHEETS EXCEPT SITE PLAN AND STANDARD DETAILS:  
"ALL RESPONSIBILITY FOR ADEQUACY OF DESIGN REMAINS WITH THE DESIGN ENGINEER. THE CITY OF ROCKWALL, IN REVIEWING AND RELEASING PLANS FOR CONSTRUCTION, ASSUMES NO RESPONSIBILITY FOR ADEQUACY OR ACCURACY OF DESIGN."
- PROVIDE KEY MAP FOR LARGE PROJECTS SHOWING SHEET LOCATIONS
- CLEAR DRAFTING WITH PROPER LINE WEIGHTS FOR EASE OF READING
- NO OVERLAPPING TEXT
- DRAFTING AT ADEQUATE SCALE TO OBTAIN EASE OF READING AND SCANNING

## COVER SHEET

NOTES:  = COMPLETE |  = DEFICIENT |  = N/A

- PROJECT NAME
- OFFICIAL PLAT NAME AS ASSIGNED BY THE PLANNING AND ZONING DEPARTMENT (INCLUDING BLOCK & LOT)
- OFFICIAL PROJECT ADDRESS ASSIGNED BY THE CITY PLANNING AND ZONING DEPARTMENT
- MAPSCO GRID REFERENCE
- MONTH AND YEAR OF PROBABLE START OF PROJECT CONSTRUCTION (UPDATED WITH EACH SUBMITTAL)
- REVISION TABLE
- ENGINEER CONTACT INFORMATION (NAME, ADDRESS, PHONE NUMBER, EMAIL ADDRESS)
- OWNER CONTACT INFORMATION (NAME, ADDRESS, PHONE NUMBER, EMAIL ADDRESS)
- SHEET INDEX - LIST ALL SHEETS INCLUDED IN PLAN SET INCLUDING DETAILS
- LOCATION MAP WITH NORTH ARROW
- SIDE BAR - PLAT SUBDIVISION NAME & PROJECT NAME
- TITLE OF TYPE OF SHEET (I.E. GRADING, UTILITY, WATER...)

## APPROVED SITE PLAN

NOTES:  = COMPLETE |  = DEFICIENT |  = N/A

- APPROVED SITE PLAN

## APPROVED LANDSCAPE/TREESCAPE PLAN

NOTES:  = COMPLETE |  = DEFICIENT |  = N/A

- APPROVED LANDSCAPE AND TREESCAPE PLAN

## PROPOSED FINAL PLAT

NOTES:  = COMPLETE |  = DEFICIENT |  = N/A

- PLAT INCLUDED
- CORRECT PLAT NAME
- PLAT CLOSURE CALCULATIONS (SEALED BY REGISTERED SURVEYOR OR ENGINEER)
- GPS GRID COORDINATES SHOWN FOR THE PROPERTY CORNERS PROPERLY INTO CITY MONUMENTATION SYSTEM (X, Y COORDINATES ON 2 PROPERTY CORNERS)
- LOCATION MAP
- STREET NAMES WITH RIGHTS-OF-WAY WIDTHS IDENTIFIED
- BENCHMARK (IF NEAR DRAINAGE FEATURE OR FLOOD ZONE)
- BASIS OF BEARING



- METES AND BOUNDS OF TRACT
- ADJACENT LAND OWNERSHIP INFORMATION
- LIST CORNERS FOUND OR SET
- PROPERTY PINS SHOWN FOR TRACTS ACROSS ROW WITH VERIFICATION OF EXISTING ROW WIDTHS
- BUILDING SETBACK LINES SHOWN
- RECORDING VOLUME AND PAGE INFORMATION FOR ALL SEPARATE EASEMENTS AND ROW DEDICATIONS WITHIN PLATTED AREA OR ADJACENT TRACTS
- 100-YEAR FLOODPLAIN FOR FULLY DEVELOPED CONDITIONS SHOWING CROSS SECTIONS AND ELEVATIONS AND WETLAND AND WATER OF U.S. DELINIATION
- MINIMUM FINISHED FLOOR ELEVATIONS SHOWN (IF NEAR DRAINAGE FEATURE OR FLOOD ZONE)
- DRAINAGE & DRAINAGE MAINTENANCE EASEMENTS SHOWN AND ANNOTATED
- REQUIRED UTILITY EASEMENTS SHOWN (20' MINIMUM WIDTH) AND ANNOTATED
- ACCESS EASEMENTS SHOWN AND ANNOTATED
- ROW. DEDICATION SHOWN AND ANNOTATED
- ROW CORNER CLIPS AND ANNOTATED
- ALL EXISTING EASEMENTS (ON-SITE) SHOWN AND ANNOTATED
- VISIBILITY EASEMENTS SHOWN AND ANNOTATED
- SURVEYOR SEAL, SIGNATURE AND DATE

**DEMOLITION PLAN**

NOTES:  = COMPLETE |  = DEFICIENT |  = N/A

- ALL EXISTING TOPOGRAPHIC FEATURES INCLUDING BUT NOT LIMITED TO: PAVEMENT, CURBS SIDEWALKS, BARRIER-FREE-RAMPS, LIGHT POLES, DRIVEWAYS, STORM SEWER INLETS, MANHOLES, JUNCTION BOXES HEADWALLS RETAINING WALLS, FENCES, MAILBOXES LANDSCAPE PLANTERS, TREES, ETC.
- ALL WET UTILITIES (WATER LINES, WASTEWATER LINES AND STORM SEWER) INCLUDING SIZES
- ALL FRANCHISE UTILITIES (ELECTRIC, CABLE, COMMUNICATIONS, GAS, ETC.)
- PAVEMENT REMOVALS WITH FULL DEPTH PAVEMENT SAWCUT LOCATIONS
- WATER LINE, WASTEWATER LINE AND STORM SEWER REMOVALS

**DIMENSIONAL CONTROL & PAVING PLAN**

NOTES:  = COMPLETE |  = DEFICIENT |  = N/A

- LOT BOUNDARY WITH DIMENSIONS AND BEARINGS
- STREET NAMES SHOWN
- EXISTING ROW
- ROW. DEDICATION AND ROW CORNER CLIPS SHOWN WITH DIMENSIONS
- VERIFICATION OF PUBLIC RIGHTS-OF-WAY WIDTH ("VARIABLE WIDTH" IS NOT ACCEPTABLE) (WHEN REQUIRED)
- VISIBILITY EASEMENTS SHOWN AS REQUIRED BY CITY CODE
- BUILDING SETBACK LINES SHOWN
- DIMENSIONS (THICKNESS, WIDTH, LENGTH, RADIUS) FOR ALL PAVED AREAS (PARKING AREAS, DRIVEWAYS, FIRE LANES, TURN LANES, DRIVE AISLES, SIDEWALKS, ETC)
- DRIVEWAYS LOCATION, SPACING AND WIDTH MEET CITY CODE AND TXDOT REQUIREMENTS
- DRIVEWAYS- WIDTH, RADIUS, DISTANCE TO ADJACENT DRIVES, ALIGNMENT WITH OTHER DRIVES ACROSS STREET SHOWN
- FIRE LANE - WIDTH, RADIUS & DISTANCE FROM BUILDING SHOWN AND DETAILED INCLUDING TURN-AROUNDS AND DEAD-ENDS
- ALL PAVEMENT THICKNESS, CONCRETE STRENGTH, REINFORCING, SUBGRADE DETAILED PER CITY REQUIREMENTS
- LOCATION OF FIRE SPRINKLER FIRE DEPARTMENT CONNECTION (FDC) SHOWN
- LOCATION OF ELECTRICAL TRANSFORMERS SHOWN



- DUMPSTER LOCATION, ACCESS AND CONSTRUCTION REQUIREMENTS MET AND APPROVED BY PLANNING AND ZONING DEPARTMENT (BACKING DISTANCE AND MANEUVER - ACCESSIBLE BY SU-30 TURNING TEMPLATE)
- ALL EXISTING AND PROPOSED UTILITY AND DRAINAGE EASEMENTS SHOWN
- EXISTING AND REQUIRED ACCESS EASEMENTS SHOWN
- SCREENING WALL LOCATION, FOUNDATION, HEIGHT, START/END OF WALL
- RETAINING WALL LOCATION, FOUNDATION, HEIGHT, START/END OF WALL
- EXISTING AND REQUIRED SIDEWALKS AND TRAILS SHOWN WITH DIMENSIONS
- SHOW LOCATION OF REQUIRED ADA RAMPS
- LIMITS OF 100-YEAR ULTIMATE FLOOD PLAIN SHOWN (FEMA AND LOCAL) AND WETLAND AND WATER OF U.S. DELINIATION
- NOTE IDENTIFYING REFERENCE FOR 100-YEAR FLOODPLAIN AND WSE INFORMATION WITH CROSS SECTION WITH ELEVATIONS
- NEW/RELOCATING LEFT TURN LANE AND/OR DECELERATION LANES COMPLIES WITH CITY AND TXDOT REQUIREMENTS (SPACING, LENGTH, CONSTRUCTION)
- EXISTING AND PROPOSED INFRASTRUCTURE WITHIN MEDIAN MODIFICATIONS SHOWN (TREES, STREET LIGHTS, CONDUIT, IRRIGATION, PAVERS, ETC)
- STREET LIGHTING AND STREET SIGN PLAN

**ROADWAY PAVING PLAN AND PROFILE**

NOTES:  = COMPLETE |  = DEFICIENT |  = N/A

- STREET NAME AND CROSS STREET NAMES
- BLOCK, LOT, AND ADDRESS LABELS
- ALL EXISTING AND PROPOSED EASEMENTS
- DIMENSIONS LABELS OF ROADWAY WIDTH, ROW WIDTH, SIDEWALK WIDTHS, CURB RETURN RADIUS, ETC.
- SHOW AND LABEL ALL STORM SEWER INLETS WITH ROADWAY STATIONING
- LEGEND SHOWING TYPE OF PAVEMENTS, THICKNESS, STRENGTH, REINFORCING, ETC.
- ROADWAY CENTERLINE STATIONING EVERY 100 FT, AL LABELS FOR ALL START, PC, PT, PI, PRC, ETC.
- DRIVEWAY CENTERLINE STATIONING LOCATION OFF ROADWAY
- LABEL CROSS-SLOPE (AT CROSS-SLOPE TRANSITIONS THE CROSS-SLOPE SHALL BE LABELED EVERY 25 FT AND AT CRITICAL DESIGN POINTS)
- SHOW AND LABEL PROPOSED PROFILE STATION AND ELEVATION (ALL SLOPES, VPI, PI, VERTICAL CURVES, LP, HP, K, E, PC, PT, VPRC, ETC.)
- SHOW AND LABEL EXISTING GROUND CENTERLINE, LEFT ROW, RIGHT ROW, AND ANY OTHER CRITICAL PROFILES
- SHOW IN PROFILE A MAJOR UTILITY CROSSING (CULVERTS, WATER/WASTEWATER TRANSMISSION LINES, GAS TRANSMISSION LINES, ELECTRIC AND COMMUNICATION DUCT BANKS)
- EXISTING AND PROPOSED GROUND LINES ELEVATION IN PROFILE EVERY 50 FT
- 100-YEAR FLOODPLAIN LINE AND WSEL

**CROSS-SECTIONS**

NOTES:  = COMPLETE |  = DEFICIENT |  = N/A

- CROSS SECTIONS SHALL BE PROVIDED FOR ALL ARTERIAL AND COLLECTOR ROADWAYS
- CROSS-SECTIONS SHALL BE TAKEN EVERY 50 FEET, DRIVEWAY CENTERLINE, INTERSECTING STREETS, AND OTHER CRITICAL POINTS OR FEATURES.
- INCLUDE EXISTING AND PROPOSED ROW LINES
- EXISTING GROUND LINE
- PROPOSED PAVEMENT THICKNESS, AND SUBGRADE DEPTHS, AND SIDEWALKS
- PROPOSED SLOPES
- CROSS-SECTIONS AT DRIVEWAYS SHALL HAVE ALL SLOPE AND VC LABELED



**GRADING PLAN**

NOTES:  = COMPLETE |  = DEFICIENT |  = N/A

- BENCHMARKS
- EXIST LOT LINES & CORNERS (LOT LINES SCREENED IF BEING CHANGED)
- PROPOSED LOT LINES
- EXISTING (SCREENED) & PROPOSED ROW
- STREET NAMES SHOWN
- DRAINAGE EASEMENTS FOR DRAINAGE FEATURES AND STRUCTURES SHOWN
- EXISTING & PROPOSED IMPROVEMENTS (PAVING AND BUILDING FOOTPRINTS)
- MINIMUM FINISHED FLOOR (FF) ELEVATIONS FOR STRUCTURES MEET REQUIREMENTS OF DRAINAGE ORDINANCE
- MINIMUM FINISHED FLOOR (FF) ELEVATION SHOWN FOR EACH STRUCTURE
- EXISTING & PROPOSED CONTOURS FOR SITE AND MINIMUM OF 50' BEYOND PROPERTY LINES (WITH APPROPRIATE CONTOUR INTERVAL) WITH ALL PONDS AND WATERWAYS LABELED
- EXISTING & PROPOSED SPOT ELEV. SHOWING GRADE; HIGH & LOW POINTS; SWALES, INVERTS & RIDGES WITH FLOW ARROWS
- LABEL LOT AREA AND DISTURBED LAND AREA
- ADJACENT PROPERTY IMPROVEMENTS WITHIN MINIMUM 25' OF SITE
- EXISTING & PROPOSED ON-SITE AND OFF-SITE DRAINAGE FEATURES (DESIGN INFO SHOWN)
- MAXIMUM CROSS SLOPE 4H:1V (H=HORIZONTAL, V=VERTICAL) MIN RUNNING SLOPE 1% FOR UNPAVED AREAS
- DITCHES ADJACENT TO SITE CLEARED, CLEANED & REGRADED (ONLY WITH PERMISSION FROM PROPERTY OWNER)
- POSITIVE OVERFLOW ROUTES WITH ELEVATIONS (ALL PUBLIC ROADS THAT HAVE A SAG REQUIRE AN OVERFLOW ROUTE)
- LOT GRADING TO BE ABOVE STREET ELEVATION (RESIDENTIAL ONLY)
- LIMITS OF EXISING AND PROPOSED 100-YEAR ULTIMATE FLOODPLAIN SHOWN AND WETLAND AND WATER OF U.S. DELINIATION
- ULTIMATE (FULLY DEVELOPED) 100-YEAR FLOODPLAIN WATER SURFACE ELEVATIONS (WSE'S) SHOWN ON CROSS SECTIONS
- NOTE IDENTIFYING REFERENCE FOR 100-YEAR FLOODPLAIN AND WSE AND WETLAND AND WATER OF U.S. DELINIATION INFORMATION
- CROSS SECTIONS TO SCALE WITH HYDRAULIC CALCULATIONS
- LOCATION OF CROSS-SECTIONS WITH STATIONING SHOWN
- CUT OR FILL AREAS SHOWN ON CROSS-SECTIONS
- EXISTING AND PROPOSED RETAINING WALLS WITH TOP & BOTTOM SPOT ELEVATIONS AND CALCULATIONS AS REQUIRED
- NO RESIDENTIAL CROSS LOT DRAINAGE
- GRADING PLAN MATCHES DRAINAGE AREA MAP
- DOES GRADING PLAN ADDRESS IMPACTS TO ADJACENT PROPERTIES REQUIRING EASEMENTS OR LETTERS OF PERMISSION
- ALL DETENTION AREAS WITH FLUMES WITH ELEVATIONS AND SIDE SLOPES LABELED

**RETAINING WALL PLAN AND PROFILES**

NOTES:  = COMPLETE |  = DEFICIENT |  = N/A

- LABEL BEGINNING AND ENDING OF WALL
- LABEL TOP OF WALL, BOTTOM OF WALL, BOTTOM OF FOOTING
- RAILING TYPE AND LIMITS
- DETAILED STRUCTURAL SECTIONS FOR EACH DIFFERING SECTION TYPE
- FLUME LOCATIONS SHOWN IN PLAN AND SECTIONS (NO WATER ALLOWED TO OVERTOP RETAINING WALLS)
- SHOW LOCATIONS OF ALL WATER, SANITARY SEWER, STORM SEWER, FRANCHISE UTILITY CROSSINGS IN PLAN
- SHOW LOCATIONS OF ALL WATER, SANITARY SEWER, STORM SEWER, FRANCHISE UTILITY CROSSINGS IN PROFILE ALONG WITH ELEVATIONS



- PROFILE EXISTING NATURAL GROUND LINE, PROPOSED GROUND LINE AT BOTTOM AND TOP OF WALL

**DRAINAGE AREA MAP**

NOTES:  = COMPLETE |  = DEFICIENT |  = N/A

- EXISTING DRAINAGE AREA MAP (PRE-PROJECT CONDITIONS), PROPOSED DRAINAGE AREA MAP (CURRENT PROPOSED PHASE OF DEVELOPMENT CONDITIONS) AND ULTIMATE DRAINAGE AREA MAP (BUILT-OUT CONDITIONS OF DEVELOPMENT)
- STORM DRAINAGE ANALYSIS AND DESIGN SHALL COMPLY WITH THE DRAINAGE ORDINANCE AND THE FLOOD HAZARD DAMAGE PREVENTION AND CONTROL ORDINANCE.
- EXISTING AND PROPOSED DRAINAGE SYSTEM AND STRUCTURES SHOWN (PIPE, INLETS, ETC)
- CURRENT ZONING OR ANTICIPATED ULTIMATE DEVELOPMENT SHOWN AND CORRECT FOR OFF-SITE AREAS
- ENSURE SITE DRAINAGE IS COLLECTED ON SITE
- DESIGN FOR AN ULTIMATE (FULLY DEVELOPED) 100 YEAR STORM EVENT
- DESIGN SHOWING ELEVATION CONTOURS FOR THE ENTIRE OFF-SITE DRAINAGE BASIN AND 50' BEYOND PROPERTY
- DESIGN WITH MOST RECENT SURVEYED CONTOUR INFORMATION
- DRAINAGE AREA MAP SHOWS SUBBASINS FOR EACH COLLECTION POINT AND INLET
- EACH DRAINAGE AREA HAS ID, Q100, ACRES AND DIRECTION OF FLOW TO THE OUTFALL SHOWN
- EACH OUTFALL LABELED WITH AN IDENTIFICATION, DIRECTION OF FLOW AND TOTAL FLOW
- DRAINAGE DIRECTION ARROWS FOR BOTH ON-SITE AND OFF-SITE DRAINAGE BASINS
- INDICATE ALL SAGS AND CRESTS WITH FLOW ARROWS
- CITY STANDARD DRAINAGE AREA MAP CALCULATION TABLE FOR CURRENT AND FUTURE CONDITIONS WITH OUTFALL SUMMARY INCLUDED
- I - VALUES MEET CITY REQUIREMENTS
- C - VALUES MEET CITY REQUIREMENTS (BASED ON ZONING)
- TIME OF CONCENTRATION VALUES USED MEET CITY REQUIREMENTS
- Q - CALCULATED FLOW IN CFS
- PROVIDE A SUBTOTAL FOR EACH MAJOR DRAINAGE LINE
- DRAINAGE AREA MAP & CALCULATIONS FOR ALL OFFSITE DRAINAGE
- LIMITS OF EXISTING AND PROPOSED 100-YEAR ULTIMATE FLOODPLAIN SHOWN AND WETLAND AND WATER OF U.S. DELINIATION
- ULTIMATE (FULLY DEVELOPED) 100-YEAR FLOODPLAIN WATER SURFACE ELEVATIONS (WSE'S) SHOWN (FEMA AND LOCAL)
- NOTE IDENTIFYING REFERENCE FOR 100 YEAR FLOODPLAIN AND WSE INFORMATION (FEMA AND LOCAL) AND WETLAND AND WATER OF U.S. DELINIATION
- SHOW LIMITS OF EACH PLAN SHEET (TILE)
- SHOW DETENTION
- SHOW EXISTING DRAINAGE AREAS (LIGHTER LINE TYPE)
- LABEL WHERE EACH DRAINAGE AREA DRAINS (INLET NUMBER, SWALE, ETC.)

**STORM DRAINAGE PLANS AND PROFILES (STORM DRAINAGE STRUCTURES INCLUDING PIPE, INLETS, ETC.)**

NOTES:  = COMPLETE |  = DEFICIENT |  = N/A

- BENCHMARK LOCATION AND ELEVATION
- FLOOD STUDY / FEMA FIRM MAP REFERENCE INFORMATION LISTED BY NOTE
- STORM SEWER ALIGNMENT LOGICAL, SHARP BENDS ELIMINATED
- COLLECTING ON-SITE DRAINAGE WITH STORM SEWER/INLETS
- PROFILE GIVEN FOR ALL STORM SEWER MAINS AND LATERALS (SHALL BE ALONG THE CENTERLINE OF PIPE)
- PIPE SIZE, MATERIAL AND CLASS IDENTIFIED ON PLAN AND PROFILE
- HYDRAULIC GRADE LINE SHOWN ON ALL STORM SEWER PROFILES FOR MAINS/LATERALS, IN BOTH FULL AND PARTIAL FLOW CONDUIT CONDITIONS



- HYDRAULIC GRADE LINE ELEVATIONS LABELED ON STORM SEWER PROFILES AT EVERY CHANGE IN FLOW, CHANGE IN PIPE SIZE, HORIZONTAL BEND, VERTICAL BEND, WYE, MANHOLE, INLET, HEADWALL, ETC.
- OTHER HYDRAULIC INFO SHOWN ON STORM SEWER PROFILES FOR ALL MAINS/LATERALS (Q100, QCAP, VELOCITY, V2/2G) ON EVERY CONDUIT SECTION BETWEEN EVERY JUNCTION AND/OR INCREASE IN FLOW
- VERTICAL AND HORIZONTAL ALIGNMENT AND SLOPE SHOWN FOR ALL MAINS/LATERALS ON PLAN AND PROFILE
- HYDRAULIC GRADE LINE MEETS CITY DESIGN REQUIREMENTS
- STARTING HYDRAULIC GRADE LINE CALCULATIONS/ASSUMPTIONS LISTED
- STARTING HYDRAULIC GRADE LINE MEETS CITY DESIGN REQUIREMENTS
- PIPE VELOCITY WITHIN ORDINANCE REQUIREMENTS AND LIMITATIONS
- ELEVATION INFORMATION ON PLAN VIEW (FLOWLINES, TOP-OF-CURB, HGL OR 100 YR WATER SURFACE (PARTIAL FLOW) AT EVERY INLET, ETC) MATCHES PROFILE VIEW
- SHOW CROSSINGS OF EXISTING AND PROPOSED WATER AND SANITARY SEWER ON STORM SEWER PROFILE
- NOTE MINIMUM COVER FOR PIPES AND CULVERTS
- DRAINAGE SYSTEM REVIEWED FOR CONSTRUCTABILITY - DEPTH AND CLEARANCE FROM STREETS, STRUCTURES, OTHER UTILITIES (DIMENSIONS)
- INLET CAPACITY CALCULATIONS PROVIDED IN CITY STANDARD TABULAR FORM
- INLETS PLACED TO CAPTURE RUNOFF BEFORE IT ENTERS STREET OR MAJOR THOROUGHFARE
- STORM SEWER CALCULATIONS PROVIDED IN CITY STANDARD TABULAR FORM
- IF STREET DRAINAGE, CALCULATIONS SHOWING CURB & STREET CAPACITY
- IF STREET DRAINAGE, SHOW NEAREST INLET & ALL UPSTREAM DRAINAGE
- INLET CONSTRUCTION LAYOUT INFORMATION SHOWN (TOP OF CURB, FLOWLINE, THROAT ELEVATION, TYPE, SIZE, HGL, Q100, ETC)
- STORM SEWER INLET LOCATION, SIZE, TYPE, AND CONSTRUCTION DETAIL PER CITY REQUIREMENTS
- STORM SEWER MANHOLE LOCATION, SIZE, TYPE, AND CONSTRUCTION DETAIL PER CITY REQUIREMENTS
- OUTFALL, HEADWALL, AND OTHER STRUCTURE LOCATION, TYPE, VELOCITY AND EROSION/SCOURING PROTECTION PER CITY STANDARDS
- POSITIVE OVERFLOW ROUTE THROUGH SITE WITH GRADES
- SAG POINTS IDENTIFIED AND PAVED POSITIVE OVERFLOW DESIGNED
- OUTFALL/HEADWALL LOCATIONS NO GREATER THAN 1' ABOVE CREEK FLOWLINE AND POINTED DOWN STREAM
- OUTFALLS DISCHARGE INTO EXISTING DRAINAGE FEATURES OR PROVIDE EASEMENTS AS REQUIRED
- OUTFALL VELOCITY MEETS CITY REQUIREMENTS
- OUTFALL PROTECTION / ENERGY DISSIPATION WHEN REQUIRED
- APPROPRIATE DETAILS ARE INCLUDED FOR STRUCTURES, JUNCTION BOXES, HEADWALLS AND INLETS (IF DIFFERENT THAN NCTCOG 4TH ED. OR CITY DETAILS)
- CONNECTION DETAILS PROVIDED FOR NON-STANDARD CONNECTIONS
- LIMITS OF EXISTING AND PROPOSED 100-YEAR ULTIMATE FLOODPLAIN SHOWN (FEMA AND LOCAL) AND WETLAND AND WATER OF U.S. DELINIATION
- ULTIMATE (FULLY DEVELOPED) 100-YEAR FLOODPLAIN WATER SURFACE ELEVATIONS (WSE'S) SHOWN (FEMA AND LOCAL)
- NOTE IDENTIFYING REFERENCE FOR 100 YEAR FLOODPLAIN AND WSE INFORMATION AND WETLAND AND WATER OF U.S. DELINIATION
- DRAINAGE EASEMENTS FOR DRAINAGE FEATURES AND STRUCTURES SHOWN (15' MINIMUM WIDTH)

**STORM DRAINAGE PLANS AND PROFILES (DITCHES, SWALES, AND OPEN CHANNELS)**

NOTES:  = COMPLETE |  = DEFICIENT |  = N/A

- DIRECTION OF FLOW INDICATED FOR DITCHES, SWALES AND OPEN CHANNELS
- DITCHES, SWALES AND OPEN CHANNELS HAVE 100 YEAR ULTIMATE WATER SURFACE SHOWN ON PROFILE (MIN 1% RUNNING SLOPE)
- DITCHES, SWALES AND OPEN CHANNELS HAVE 100 YEAR ULTIMATE WATER SURFACE SHOWN ON CROSS SECTIONS
- DITCHES, SWALES AND OPEN CHANNELS ARMORED WITH APPROVED MATERIAL IN AREAS WHERE AVERAGE & LOCALIZED VELOCITIES ARE ABOVE 6 FPS
- DITCHES, SWALES AND OPEN CHANNELS CAN CARRY 100-YEAR ULTIMATE STORM WITH REQUIRED FREEBOARD



- DITCHES, SWALES AND OPEN CHANNELS HYDRAULIC INFORMATION SHOWN ON PLANS
- DITCHES, SWALES AND OPEN CHANNELS HYDRAULIC INFORMATION SHOWN ON PLANS MATCHES HYDRAULIC REPORT OR FLOOD STUDY SUBMITTED
- DITCHES, SWALES AND OPEN CHANNELS SIDE SLOPES LESS THAN 4H:1V FOR GRASSED/UN-ARMORED SECTIONS
- DITCH, SWALE AND OPEN CHANNEL WIDTH, DEPTH, RUNNING AND SIDE SLOPES AND CAPACITY PER CITY REQUIREMENTS
- DRAINAGE EASEMENTS FOR DRAINAGE FEATURES AND STRUCTURES SHOWN

**STORM DRAINAGE PLANS (DETENTION AND PONDS)**

NOTES:  = COMPLETE |  = DEFICIENT |  = N/A

- REQUIRED DETENTION SHOWN
- DETENTION CALCULATION SHOWN AND CORRECT
- OUTFALL DISCHARGE CURVES FOR REQUIRED STORM EVENTS
- DETENTION/RETENTION POND LOCATION, SIZE, DEPTH, CAPACITY, AND MATERIAL PER CITY REQUIREMENTS, 100 YEAR WATER SURFACE ELEVATIONS
- PROVIDE ACCESS AND STRUCTURES THAT CONTRIBUTE TO LONG TERM MAINTENANCE OF DETENTION POND
- DRAINAGE EASEMENTS FOR DRAINAGE FEATURES AND STRUCTURES SHOWN (15' MINIMUM WIDTH)
- PROVIDE CHART SHOWING FLOW ALLOWABLE VS. FLOW ACTUAL FOR Q5, Q10, Q25, AND Q100

**WATER**

NOTES:  = COMPLETE |  = DEFICIENT |  = N/A

- WATER MAIN SIZED IN COMPLIANCE WITH WATER SYSTEM MASTER PLAN
- WATER MAINS PROVIDED TO FRONT PROPERTY ALONG ALL STREET FRONTAGES OR OTHERWISE EXTENDED TO SERVE ADJACENT PROPERTIES
- WATER MAIN EXTENSION REQUIRED BY CODE SHOWN
- WATER MAINS LOOPED TO PROVIDE CIRCULATING AND REDUNDANT FEED
- WATER MAIN SIZE, MATERIAL AND CLASS CALLED OUT
- EXISTING WATER MAINS AND VALVES SHOWN; SHOW VALVES ON BOTH SIDES OF TAP IN CASE AREA NEEDS TO BE ISOLATED
- EXISTING & PROPOSED FIRE HYDRANTS SHOWN
- UTILITY EASEMENTS FOR WATER MAINS SHOWN
- PROPOSED AND EXISTING FIRE LANES SHOWN
- FIRE HYDRANT SPACING MEETS REQUIREMENTS OF ADOPTED INTERNATIONAL FIRE CODE (IFC)
- FIRE SPRINKLER FIRE DEPARTMENT CONNECTION (FDC) LOCATION SHOWN
- WATER MAIN FITTINGS, VALVES, ETC IDENTIFIED
- WATER MAINS 16" AND LARGER PROFILED
- ALL WATER MAIN BORES PROFILED
- ALL CROSSINGS IDENTIFIED ON APPROPRIATE PROFILE
- BORE COMPLIES WITH BORE AND UTILITY CROSSING GENERAL DESIGN STANDARDS AND TXDOT STANDARDS IF IN TXDOT ROW
- EXISTING WATER METERS SHOWN
- PROPOSED WATER METERS SHOWN (BOTH DOMESTIC AND IRRIGATION)
- DOMESTIC AND IRRIGATION WATER METERS ON LOOPED/CIRCULATING MAIN
- ALL WATER METERS ON SEPARATE SERVICE - NO WATER METER "BULLHEADS" OR MANIFOLDS ALLOWED
- WATER METERS LOCATION, PREFERRED TO BE IN UNPAVED AREA
- WATER METER SIZES IDENTIFIED
- APPROPRIATE DOUBLE CHECK/BACKFLOW PREVENTION SHOWN ON PRIVATE SIDE OF ALL METERS



- WATER SYSTEM REVIEWED FOR CONSTRUCTABILITY AND MAINTENANCE - DEPTH AND CLEARANCE FROM STREETS, STRUCTURES, OTHER UTILITIES (DIMENSIONS)
- WATER MAINS IDENTIFIED AS EITHER PUBLIC OR PRIVATE WITH LINES OF DEMARCATION
- UTILITY CROSSINGS SHOWN IN ALL PROFILES AND BORE PROFILES INCLUDING FRANCHISE UTILITIES AND STREET LIGHT UTILITIES
- IF FIRE SPRINKLER LINE IS SHOWN, ADD NOTE TO PLANS TO INDICATED THE REQUIREMENT FOR SEPARATE PERMIT FROM THE FIRE DEPARTMENT AND LABEL MIN 10-FOOT SEPARATION DISTANCE FROM ALL OTHER UTILITIES

**WASTEWATER**

NOTES:  = COMPLETE |  = DEFICIENT |  = N/A

- WASTEWATER MAINS PROVIDED TO FRONT PROPERTY OR OTHERWISE EXTENDED TO SERVE UPSTREAM PROPERTY
- EXISTING WASTEWATER MAINS, MANHOLES, CLEANOUTS AND SERVICES SHOWN
- PROPOSED WASTEWATER MAINS, MANHOLES, CLEANOUTS AND SERVICES SHOWN
- SANITARY SEWER MAINS PROFILED ALONG CENTERLINE OF PIPE
- BORE COMPLIES WITH BORE AND UTILITY CROSSING GENERAL DESIGN STANDARDS AND TXDOT STANDARDS IF IN TXDOT ROW
- WASTEWATER MAIN SIZE, MATERIAL AND CLASS IDENTIFIED ON PLAN AND PROFILE
- WASTEWATER MAIN DEPTH, SLOPE, SERVICE LOCATIONS, CLEANOUTS AND MANHOLES SHOWN IN ALL PROFILES
- WASTEWATER RIM, FLOW LINE IN & FLOW LINE OUT ELEVATIONS FOR ALL MANHOLES (MIN 2% DROP BETWEEN MANHOLE FLOW-IN AND FLOW-OUT)
- UTILITY CROSSINGS SHOWN IN ALL PROFILES AND BORE PROFILES INCLUDING FRANCHISE UTILITIES AND STREET LIGHT UTILITIES
- WASTEWATER SYSTEM REVIEWED FOR CONSTRUCTABILITY AND MAINTAINABILITY - DEPTH AND CLEARANCE FROM STREETS, STRUCTURES, OTHER UTILITIES (DIMENSIONS)
- ALL EXISTING AND PROPOSED PUBLIC AND PRIVATE EASEMENTS AND RIGHTS OF WAY SHOWN
- WASTEWATER MAINS IDENTIFIED AS EITHER PUBLIC OR PRIVATE WITH LINES OF DEMARCATION AND PRIVATE UTILITY NOTE
- PRIVATE UTILITY NOTE: "ALL WASTEWATER WORK DESIGNATED AS "PRIVATE" IN THIS SET OF PLANS SHALL BE INSTALLED IN ACCORDANCE WITH THE INTERNATIONAL PLUMBING CODE, PERMITTED AND INSPECTED BY THE CITY BUILDING INSPECTION DEPARTMENT AND INSTALLED BY A LICENSED PLUMBER."
- LIMITS OF EXISTING AND PROPOSED 100-YEAR ULTIMATE FLOODPLAIN SHOWN (FEMA AND LOCAL) AND WETLAND AND WATER OF U.S. DELINIATION
- ULTIMATE (FULLY DEVELOPED) 100-YEAR FLOODPLAIN WATER SURFACE ELEVATIONS (WSE'S) SHOWN (FEMA AND LOCAL)
- NOTE IDENTIFYING REFERENCE FOR 100 YEAR FLOODPLAIN AND WSE INFORMATION AND WETLAND AND WATER OF U.S. DELINIATION

**LIFT STATION**

NOTES:  = COMPLETE |  = DEFICIENT |  = N/A

- LIFT STATION REPORT
- DIMENSION AND SITE PLANS
- GRADING PLAN
- FORCE MAIN PLAN AND PROFILE
- LANDSCAPE PLAN
- ELECTRICAL AND CONTROL PLANS
- DETAIL SHEETS

**EROSION CONTROL (FOR SITES GREATER 1- ACRE OR LARGER) / SWP3 (IF REQUIRED BY TCEQ REGULATIONS)**

NOTES:  = COMPLETE |  = DEFICIENT |  = N/A

- OWNERS NAME, ADDRESS & PHONE NO.
- DEVELOPERS NAME ADDRESS & PHONE NO.
- ENGINEERS NAME ADDRESS & PHONE NO.
- SITE ACREAGE LISTED





- DISTURBED ACREAGE LISTED (ACRES)
- LIMITS OF CONSTRUCTION AND DISTURBED AREAS SHOWN
- EXISTING GROUND CONTOURS, DRAINAGE FEATURES AND STRUCTURES
- 100-YR FLOOD PLAIN WITH ELEVATIONS (FEMA AND LOCAL) AND WETLAND AND WATER OF U.S. DELINIATION
- LIMITS OF TREES/SHRUBS TO REMAIN
- GRADES TO MATCH GRADING PLAN
- PROPOSED STORM DRAINAGE, STRUCTURES & PAVEMENT
- BORROW & SPOIL AREA IDENTIFIED
- BMP LOCATIONS, DETAILS, CALCULATIONS, AND MAINTENANCE SCHEDULE
- SEDIMENT BASIN, REQUIRED IF DISTURBED AREA GREATER THAN 10 ACRES

**STANDARD DETAILS AND CITY GENERAL NOTES**

*NOTES:*  = COMPLETE |  = DEFICIENT |  = N/A

- ALL STANDARD DETAILS THAT ARE REQUIRED FOR CONSTRUCTION FROM STANDARD SPECIFICATIONS FOR PUBLIC WORKS CONSTRUCTION, NORTH CENTRAL TEXAS, FIFTH EDITION, OR THE CITY OF ROCKWALL STANDARDS OF DESIGN AND CONSTRUCTION SHALL BE INCLUDED IN ALL PLAN SETS.
- CITY GENERAL NOTES SHEETS

**TXDOT DETAILS**

*NOTES:*  = COMPLETE |  = DEFICIENT |  = N/A

- INCLUDE ALL PERTINENT DETAILS CALLED OUT IN PLANS





APPENDIX B | APPROVED WATER MATERIALS LIST



## APPROVED WATER MATERIALS LIST

All materials on this list do not require separate submittals. All materials must be new and in good condition. All materials to be installed for use on projects in the City of Rockwall shall be produced in the United States of America

### FIRE HYDRANTS

NOTE: ALL BOLTS, NUTS AND WASHERS BELOW *BURY LINE* TO BE TYPE 316 STAINLESS-STEEL.

- Mueller “Super Centurion 250-A423”
- American Darling “B-84B-5”
- Waterous “Pacer WB67”
- Clow “Medallion”
- M&H “Model 129 & 929”
- WaterMaster 5CD250

### VALVES

NOTE: ALL BOLTS, NUTS AND WASHERS FOR VALVES TO BE TYPE 316 STAINLESS-STEEL.

- Mueller Resilient Seat
- Mueller Resilient Wedge
- Mueller Butterfly
- American Darling Resilient Wedge
- American Darling Butterfly
- U.S. Pipe & Foundry “Metro-Seal” Resilient Wedge
- American Flow Control – Series 2500 Resilient Wedge Valve
- Clow Resilient Wedge
- Pratt Butterfly
- American AVK Resilient Seated Gate Valve Series 25, 4”-12”

### VALVES (AIR RELEASE / COMBINATION AIR & VACUUM)

- Vent-O-Mat 025 RBX 2521 – 1”
- Vent-O-Mat 050 RBX 2521 – 2”

### TAPPING SLEEVES AND VALVES

NOTE: ALL BOLTS, NUTS AND WASHERS TO BE TYPE 316 STAINLESS-STEEL.

- All require ¾” NPT brass test plug.

### SLEEVES

NOTE: ALL BOLTS, NUTS AND WASHERS TO BE TYPE 316 STAINLESS-STEEL.

- Mueller H-304 Stainless-steel Tapping Sleeve w/Stainless-steel Flange
- Tyler Traverse Tapping Sleeve
- Clow Traverse Tapping Sleeve
- Dresser Style 630 Heavy Stainless-Steel Tapping Sleeve
- PowerSeal Model 3490 Stainless-steel Tapping Sleeve
- Ford All Stainless Tapping Sleeve Style FTSS
- Ford All Stainless Tapping Sleeve Style FTSS-MJ
- Smith-Blair 665 Stainless-steel Tapping Sleeve with Stainless-steel Flange, Smith-Blair 665MJ Stainless-steel Tapping Sleeve with Stainless-steel Flange Romac Industries, SST III

**TABLE B.1: SERVICE SADDLES (FOR PVC, DI OR CI)**

SIZE/MANUFACTURER	MUELLER	JONES	FORD	A.Y. MCDONALD
¾-INCH, 2 STRAP	BR-2B, BR-2S	J-979, J-969	202B, 202BS	3825, 3845
1-INCH, 2 STRAP	BR-2B, BR-2S	J-979, J-969	202B, 202BS	3825, 3845
1 ½ -INCH, 2 STRAP	BR-2B, BR-2S	J-979, J-969	202B, 202BS	3825, 3845
2-INCH, 2 STRAP	BR-2B, BR-2S	J-979, J-969	202B, 202BS	3825, 3845

**NOTE:** ALL OF THE ABOVE SERVICE SADDLES ARE TO BE CC THREAD. SADDLES MUST BE SUPPLIED WITH STAINLESS-STEEL BOLT/NUT/WASHER, WITH THE EXCEPTION OF A DOUBLE STRAP BRONZE SADDLE.

**RESTRAINT (RETAINER) GLANDS**

**NOTE:** ALL BOLTS, NUTS AND WASHERS TO BE TYPE 316 STAINLESS-STEEL.

- Uni-Flange Series 1400 for 4" thru 12" (Ductile Iron)
- Uni-Flange Series 1500 for 4" thru 12" (C900 PVC)
- EBAA Iron 1100 Series Megalug (Ductile Iron)
- EBAA Iron 2000PV Series Megalug (C900 PVC)
- Stargrip Series 4000 (C900 PVC)
- Stargrip Series 3000 (Ductile Iron)
- Sigma – One Lok (C900/905 PVC)
- Tyler Union Field Lock (Ductile Iron)
- Tyler Union Tufgrip 1000 (Ductile Iron)
- Tyler Union Tufgrip 2000 (PVC)

**RESTRAINT (INTERNAL JOINT RESTRAINED)**

**NOTE:** ALL BOLTS, NUTS AND WASHERS TO BE TYPE 316 STAINLESS-STEEL.

- Eagle LOC 900 for 4" thru 12" C900 DR14 PVC Pipe
- Diamond Lok-21 for 4" thru 12" C900 DR14 PVC Pipe

**TABLE B.2: CORPORATION VALVE (STOPS)**

SIZE/MANUFACTURER	MUELLER	JONES	FORD	A.Y. MCDONALD
¾-INCH	B-25008	J-1937-SG	FB-1000-3-Q	4701BQ
1-INCH	B-25008	J-1937-SG	FB-1000-4-Q	4701BQ
1 ½ -INCH	B-25008	J-1937-SG	FB-1000-6-Q	4701BQ
2-INCH	B-25008	J-1937-SG	FB-1000-7-Q	4701BQ

**TABLE B.3: ANGLE METER VALVES (STOPS)**

SIZE/MANUFACTURER	MUELLER	JONES	FORD	A.Y. MCDONALD
¾-INCH	B-24258	J-1963W-SG	BA43-332-WQ	4602BQ 3/4
1-INCH	B-24258	J-1963W-SG	BA43-444-WQ	4602BQ 1
1 ½ -INCH	B-24276	J-1975W-SG	BFA43-666-WQ	4602BQ 1 ½
2-INCH	B-24276	J-1975W-SG	BFA43-777-WQ	4602BQ 2

**DUCTILE IRON FITTINGS (COMPACT ONLY C153)**

- American Pipe
- Tyler Pipe Products
- Clow Products
- Star Pipe Products (tees, bends & anchor nipples)
- Sigma/Nappco Products (tees, bends & anchor nipples)
- Griffin Pipe Products



## VALVE STACKS AND BOXES

- Bass & Hays adjustable valve box Model No. 2436S

**TABLE B.4: FIRE HYDRANT PAINT**

MAIN SIZE	COLOR	PAINT
6"	SILVER/TOP & BOTTOM	SHERWIN WILLIAMS SILVER-BRITE HEAVY DUTY RUST RESISTANT ALUMINUM PAINT B59S11
8"	SAFETY BLUE TOP/ALUMINUM BOTTOM	SHERWIN WILLIAMS HEAVY DUTY RUST RESISTANT ALUMINUM PAINT-SAFETY BLUE B54T104
10" OR LARGER	YELLOW TOP/ALUMINUM BOTTOM	SHERWIN WILLIAMS HEAVY DUTY RUST RESISTANT ALUMINUM PAINT-SAFETY YELLOW B54Y37

**TABLE B.5: METER BOXES**

< 1 INCH SERVICE	DFW1814F-1BA   DFW PLASTICS, INC   NOT TRAFFIC RATED
1-1/2-INCH, 2-INCH SERVICE	DFW2818F-1BA   DFW PLASTICS, INC   NOT TRAFFIC RATED
TRAFFIC RATED METER BOX	DFW65C-14-10BA   DFW65C-1BA – CAN   DFW65C-OVERLAY-LID   DFW PLASTICS
LIDS	DFW 18-AMRL-LID E SERIES



APPENDIX C | APPROVED WASTEWATER MATERIALS LIST



## Approved Wastewater Materials List

NOTE: ALL SPECIFIED MATERIALS ON THIS LIST DO NOT REQUIRE SEPARATE SUBMITTALS. ALL MATERIALS MUST BE NEW AND IN GOOD CONDITION.

### WASTEWATER MAIN AND SERVICE PIPE (GRAVITY FLOW ONLY)

- ASTM D3034 SDR-35 PVC 4" to 15" Diameter (Green in color)
- ASTM D3034 SDR-26 PVC 18" to 30" Diameter and for any wastewater installed 10' and deeper (Green in color)
- ASTM D3262 Fiberglass Sewer Pipe 18" to 54" and ASTM 4161 Fiberglass Fittings (must submit thickness design for wall thickness calculations) Approved Manufactures for Fiberglass Pipe and fitting are Hobas Pipe, US Composite Pipe South and Ameron International.

### MANHOLE PIPE CONNECTORS

- Link-Seal
- A-LOC
- KOR-N-SEAL – 306 Series by National Pollution Control Systems Inc.
- PS (Press-Seal) – PSX: Direct Drive

### WASTEWATER MANHOLE LIDS AND RINGS

- Pamrex with Lock
- East Jordan Iron Works 30" ERGO XL with Camlock Security closing device, MPIC Pick slot, elastomer T-Gasket in lid and infiltration plugs at the hinges. – Product No. 00148026L01
- East Jordan Iron Works 24" ERGO with Camlock Security closing device, MPIC Pick slot, elastomer T-Gasket in lid and infiltration plugs at the hinges – Product No. NPR10-1213A (for retrofit work only).

### MANHOLE COATINGS (NO DARK COLORS ALLOWED)

- Raven 405 (125 mils thick)-light blue colored only
- ConShield-terra cotta colored only (must be spark tested per NACE International Standard)

### GEOTEXTILE MATERIAL (INSTALLED UNDER PRECAST MANHOLES)

- Mirafi 140N
- Geotex 401

### MANHOLE GRADE RINGS

- HDPE Adjustment Rings by Ladtech Inc.
- ARPRO Expanded Polypropylene, ASTM D3575, by Cretex Seals
- East Jordan Iron Works Infra-Riser.

### PRE-CAST MANHOLE GASKETS

- Hanson – CR 097
- Hydroconduit – Profile

### MANHOLE CHIMNEY SEALS AND RING & COVER SEALING SYSTEMS

- Cretex with stainless-steel self-locking bands. (interior & exterior)
- Riser Wrap by PSI

### MANHOLE DROP BOWL





- Reliner / Duran Inc., Inside Drop Bowl with Stainless-steel anchor assemblies
- Approved Equal

#### CLEANOUT

- Bass & Hays 404 Lateral Cleanout with lid and gasket within pavement only
- Bass & Hays 339 Wastewater Cleanout Boot
- Stan Roberts G-1504

#### DOUBLE CLEANOUT METER BOX

- Bass & Hays 3-LID2 (Sewer)
- Approved Equal

#### THREADED ANCHOR

- Hilti – KB3-SS304 5/8" anchor bolts or equal
- Stainless-steel all thread 5/8" (embedded min 4-1/2" into cone with a epoxy or Wedge-it)
- Simpson Strong Tie – Strong-Bolt 5/8"

#### FORCE MAIN PIPE

- AWWA C-905 pipe, green colored

#### AIR RELEASE VALVE

- Vent-O-Mat Anti-Shock Air Release and Vacuum Break Valves
- Approved Equal

#### ISOLATION GATE VALVE

- American-Series 2500 2"-12" Resilient Wedge Gate Valves with Flanged Ends
- Approved Equal

#### **GENERAL NOTES:**

- (1) ALL EXPOSED STAINLESS-STEEL BOLTS AND NUTS MUST BE COATED WITH APPROVED ANTI-SEIZE COMPOUND: PERMATEx NICKEL ANTI-SEIZE OR APPROVED EQUAL.
- (2) MATERIALS NOT ON THIS LIST WILL NEED TO BE SUBMITTED FOR REVIEW.





APPENDIX D | EXAMPLE CHECKLIST FOR FINAL ACCEPTANCE  
(RESIDENTIAL AND COMMERCIAL)



## EXAMPLE: CHECKLIST FOR FINAL ACCEPTANCE OF A RESIDENTIAL PROJECT

(DATE)

(ENGINEER'S NAME)  
 (ENGINEERING COMPANY)  
 (ADDRESS)  
 (CITY, TX ZIP)

RE: (PROJECT NAME) – CHECKLIST FOR FINAL ACCEPTANCE

Dear (ENGINEER'S NAME),

The following items are to be completed at the above-mentioned site to bring the project into compliance with City specifications and to meet specific project requirements. The listed items are items identified during the walkover of the site and are to be addressed prior to final acceptance of the project. The City will conduct daily site visits (during daily rounds) at the project until completion of the noted items. A copy of this list will also be directed to the developer/owner and general contractor. The below listed items are to be directed to the appropriate responsible parties for completion.

### *REQUIRED DOCUMENTATION*

- (1) The City of Rockwall requires that the design engineer provide a letter of concurrence. The letter is to verify that the drainage flow patterns, grade to drain locations, pad elevations, and drainage structures, including the volume of the surface and/or subsurface detention system and detention outlet structure located at the project were installed to the general elevations as shown on the approved plans. The letter shall also verify that the project was constructed to meet the approved design requirements or is within acceptable design tolerances. The Design Engineer or his designated representative shall direct all "survey-work" necessary to verify elevations and design compliance. The letter of concurrence is to have the seal and signature of the design engineer.

#### *EXAMPLE OF LETTER OF CONCURRENCE VERBIAGE WHICH WILL NOT BE ACCEPTED BY THE CITY:*

*A representative of this company visited the site and has visually verified to the best of the engineer's professional opinion, knowledge and belief, the final grading and site drainage comply with the City approved plans and details.*

#### *EXAMPLE OF LETTER OF CONCURRENCE VERBIAGE WHICH WILL BE ACCEPTED BY THE CITY:*

*A representative of this company visited the site and has visually verified to the best of the engineer's professional opinion, knowledge and belief, that based on my observations along with survey work conducted at the site, the final grading, site drainage, and detention outfall with required volume comply with the City approved plans and details.*

- (2) The Design Engineer shall furnish a digital file of the project formatted in Auto Cad 14, or 2000 format or newer and Adobe Acrobat (pdf.) format with a CD-ROM. The disk shall include a full set of plans along with any landscaping, wall plans, and details sheets.

Submit one (1) set of blue line drawings of the "Record Drawings" containing copies of all sheets. The blue line copy will be reviewed by the construction inspector **PRIOR** to producing the "Record Drawing" disk. This will allow any revisions to be addressed prior to producing the disk.

***RECORD DRAWING DISK DRAWINGS SHALL HAVE THE DESIGN ENGINEERS SEAL, SIGNATURE AND MUST BE STAMPED AND DATED AS "RECORD DRAWINGS" OR "AS BUILT DRAWINGS" ON ALL SHEETS.***

The City of Rockwall will not accept any Record Drawing disk drawings which include a disclaimer with the like or similar verbiage. A disclaimer shall not directly or indirectly state or indicate that the design engineer or the design engineers, surveyor/surveyors did not verify or grades after construction, or that the Record Drawings were based solely on information provided by the construction



contractor/contractors. Any Record Drawings which include like or similar disclaimer verbiage will not be accepted by the City of Rockwall.

**EXAMPLE OF ACCEPTABLE DISCLAIMER:**

*To the best of our knowledge Smith Engineering, Inc., hereby states that this plan is As-Built. This information provided is based on surveying at the site and information provided by the contractor.*

- (3) 4% Engineering Inspection Fee (Final As-Built Adjustments). Prior to the start of construction at the project, engineering inspection fees for the project were established. The preliminary inspection fee amounts were based upon the projected contract quantity and unit price amounts which were submitted to the City. A fee based on 4% of the projected quantity cost was paid to the City. The final fee amounts are to be adjusted if necessary to match the unit quantity and unit price amounts based on the as-built contract unit quantity amounts. Please provide a copy of the as-built quantity amounts with total amounts for each item. The as built amounts should be noted or stamped as “as-built contract quantity and unit price amounts”. The engineering inspection fee charged by the City will be adjusted to match these amounts if necessary. The City is to receive payment on the adjusted cost amounts prior to project acceptance. As-built contract unit quantity and unit price amounts for the pavement, drive approaches, sidewalks, barrier free ramps, wastewater, storm sewer, drainage structures (including underground detention), water lines, along with all associated fixtures which are located within the defined rights-of-way and easements of the project.
- (4) All weekday and weekend overtime engineering inspections fees are to be paid.
- (5) Flood study review fees to be paid if there is an excess due over the initial review fee. If all of the initial fees were not utilized for the flood study review, those monies will be refunded.
- (6) Gas and Electric facilities are to be installed at the site and be ready to provide service to each lot. A letter of installation verification and operation will be required from electric and gas project managers and will need to be directed to the City of Rockwall prior to project acceptance or any early lot releases. The letter may be from the above noted parties or their designated representatives.
- (7) Storm Sewer Outfall Coordinates. It is now necessary to tie down all the storm sewer outfall pipes to our state plane Coordinate System. The design engineer will be required to provide the following coordinate information which is to be submitted in letterform showing the x, y, and z coordinates at the end of all storm sewer outfalls of the project.
- (8) The City of Rockwall – Elevation Survey Monuments which are to be installed at the project shall be tied to the City of Rockwall monument coordinates both horizontally and vertically. The information shall be transferred to the City of Rockwall. Elevations and monument locations are to be shown on the as built mylars on both the paving plans and the storm sewer plans and shall also be submitted to the City in letter-form. The monuments are to be supplied by the City of Rockwall and installed by the utility contractor. The monument locations are as follows:
  - (A) (LOCATION)
  - (B) (LOCATION)
- (9) Right-of-way Compaction and Density Reports. Final grade densities are to be conducted at approximately each 500 – foot intervals on both sides of each street in the general fill areas of the rights-of-way. Full Depth trench densities are to be taken at all utility trenching locations where trenching operations consisted of cutting trench 10-inches wide or wider. All final grade right-of-way and easement compaction density tests are to be a minimum of 95% of the standard proctor density. Copies of the compaction tests performed for the developer’s contractors as well as by the franchise utility company’s contractors shall be provided to the City prior to project acceptance.
- (10) Maintenance bonds are to be submitted to the City of Rockwall for the paving and utilities installed at the project. The bonds shall be two-year 10% maintenance bonds to cover maintenance, for a two-year timeline starting from the “Date of City of Rockwall’s Acceptance” for the project. There is to be no date in the starting timeline only the above wording.
  - (A) The utility bond shall cover the following utility systems and their associated fixtures.
    - Water
    - Wastewater
    - Storm sewer (including detention systems)
  - (B) The paving bond shall cover the following:
    - Street Pavement.



- Driveway Approaches
- Sidewalks.
- Barrier free ramps.

- (11) Engineered Retaining Wall Inspection & Letter of Concurrence. The City requires the design engineer for any retaining wall which is three-feet in height or taller, to periodically inspect, or make arrangements for his designated representative to periodically inspect the retaining wall/walls during the construction process. The design engineer is to submit letter of concurrence for the retaining wall/walls to the City prior to project acceptance. The letter shall contain the seal and signature of the retaining wall design engineer.
- (12) City Council approved and owner signed final/replat plat mylars and tax certificates to be submitted to Planning Department for filing.

#### SITE ITEMS

- (1) Site Working Hours and Noise Control Signage (Ordinance No. 05-45). Signs are to be placed at all entrances, which provides an access entry way into the subdivision. The signs are to note allowed hours of construction as mandated by the City Ordinance. The signs must be installed prior to project acceptance or prior to the start of any early lot release construction. The signs may be placed in the City right-of-way provided that it is not placed within the 30-foot visibility easement clips, which are located at all street intersections. Each posted sign shall contain the following ordinance work-hours information and contain both the English and the Spanish version of the ordinance. The face of the sign shall be a minimum of 4-feet wide by 3-feet tall with the sign post being approximately 4-feet tall when measured from the top of the ground to the bottom of the sign face. The maximum height of the sign shall not exceed a height of 7-feet, 6 inches when measured from the top of the ground to the top of the sign. The sign face shall consist of a white background with blue or black lettering. The letters shall be of sufficient size so as to be readily visible to all vehicular traffic entering the subdivision.

### **CITY OF ROCKWALL - ORDINANCE**

#### **ORDINANCE # 05-45 CONSTRUCTION SITE WORKING HOURS AND NOISE CONTROL**

City Ordinance – No. 05-45 limits construction and construction related activities to the hours of 7:00 a.m. - 7:00 p.m. Monday through Friday, and 8:00 a.m. - 7:00 p.m. on Saturday. (No Sunday construction allowed).

#### **ORDENANZA # 05-45 HORAS DE TRABAJO EN EL SITIO DE CONSTRUCCION Y EL CONTROL DE RUIDO**

La Ordenanza de la Ciudad – No. 05-45 limita la construcción y las actividades relacionadas con la construcción a las horas de 7:00 a.m. – 7:00 p.m. de Lunes a Viernes, y de 8:00 a.m. – 7:00 p.m. los Sábados. (No se permitirá construcción los Domingo).

- (2) The maximum slope allowed by the City will be a 4:1 slope, however this slope will only be allowed when it is not possible or feasible to achieve a slope of 4:1 or less. Retaining walls or other City approved retaining methods will be required where it is not possible or feasible to comply with the 4:1 maximum slope requirement. All slopes are to be compacted to 95% of the standard proctor density.
- (3) Install floodway monument markers. The City will furnish the marker cap, which is to be set in concrete as directed by the City of Rockwall. The developers designated representative shall install the marker prior to project acceptance. Monument installation shall meet City of Rockwall specifications.
- (A) The monument marker location is to be shown on the Record Drawing Mylar's on the grading plan.
- (B) The City of Rockwall will furnish the marker cap.
- (C) Install "No Dumping, Drains to Waterway" inlet markers to be installed on each inlet by the developer



- (4) Street Address Marker Blocks. Street address marker blocks shall be painted on the curbs in the center of each lot and comply with the City of Rockwall specifications. The street address markers are to be installed at each lot in the subdivision. The markers shall be located at the center of the lot on the face of the street curb. The address markers shall have a Forest green background with reflective white numbers. The number size shall be four-inches in height. The background of the address marker shall be eighteen-inches in length and be located from the top of the curb to the gutter flow line. The address marks shall show the full numerical portion of the address of the lot.
- (5) Interior Erosion Protection. Install reinforced silt fencing which complies with (NCTCOG) standard drawing (1020A) Third Addition. Silt fencing is to be installed at the back of the street pavement curbs and at 1-foot off the outside pavement edge of the alleys. The silt fence should contain the entire perimeter of the disturbed lot areas.
- (6) When installing the silt fence at the street (back of curb) and alley (edge of paving) locations take care to address the following issues:
  - (A) Allow for a clearance radius of 5-feet around each hydrant.
  - (B) Block the silt fence around and to the backside of each water meter.
  - (C) When placing the silt fence at an alley intersection be sure to transition the silt fence to allow a turning radius for vehicles.
  - (D) Do place the silt fence within the sight visibility easements which are located at the street and alley intersections.
- (7) Maintain existing or install additional construction site erosion BMP's as necessary, to stabilize the disturbed soil or contain silt migration.
- (8) All street and alley parkways and right-of-way locations are to be graded so as to obtain a 2% grade (1/4-inch per foot) slope. All parkways and right-of-way locations are to have positive drainage flow towards the street or alley to the right-of-way. The transitional grading from the right-of-way to the existing natural grade is to match the approved grading plans.
- (9) Final Site Grading. All grading is to be completed and verified to meet the approved grading plans. All graded areas including slopes are to be brought to a final grade surface that is smooth and uniform being relatively free of erosion washouts, tire ruts, dirt clods, silt deposits, etc., care should be taken to re-grade any rough surface areas prior to the application of grass seed, sod or erosion matting.
- (10) Remove and dispose any miscellaneous construction related debris, trash rocks etc. from the job-site and properly dispose.
- (11) Rout and seal all miscellaneous random cracks which are located in the street and alley locations.
- (12) Provide the construction inspector with electronic copies of all testing reports for the project. These shall include but not be limited to soils reports, utility densities, utility videos along with supporting documents, subgrade test reports and all concrete related reports for utilities and paving.
- (13) Conduct a video survey of the public sanitary and storm lines to the construction inspector assigned to the project. Videos shall be taken after the franchise utilities on the project have been completed.
- (14) Complete the installation of all barrier free ramps.
- (15) Construct all sidewalks that are located in the common open areas.
- (16) Clean and sweep all roadways to remove all of the dirt and debris that has accumulated during construction.
- (17) Random Pavement Depth Checks. Random depth core test is to be conducted at various street and alley locations, as directed by the engineering inspector. The location of the test and the number of test necessary will be left to the discretion of the engineering inspector.
- (18) Complete the landscaping per the approved landscaping plans.
- (19) Fire hydrants are required to have a nozzle height of 19-inches to 28-inches above the final grade elevation. Hydrant nozzles that do not meet this specification are to be raised or lowered as necessary to obtain compliance.
- (20) All fire hydrants are to have a clearance radius of 5-feet in all directions. No structures, traffic bollards, silt fencing, landscaping etc., are to be placed within the clearance area.
- (21) Paint all fire hydrants located at the site to City specifications. A minimum of two coats of aluminum paint, Mobile 11-A-19 or Tnemec 2-color Tnemec-Gloss or approved equal are to be applied to each hydrant. The fire hydrant body shall be painted silver. The hydrant



nozzle and bonnet are to be painted to comply with the following line size color code. The color indicating the line size shall be as follows:

- (A) Solid silver for 6-inch water mains.
- (B) Blue for 8-inch lines water mains.
- (C) Yellow for 10-inch water mains and above.

(22) Water Valve and Waste Water Manhole Curb Cut Marks. The pavement curbs are to be marked at all water valve and waste water manhole locations. The curb cut marks are to be sawn into the pavement curb. The curb cut marks are to consist of the following:

- (A) Valves. Place a (V) mark on the curb to note the valve locations, (blue paint for general, white paint for stub outs or dead ends, and red paint for fire hydrants and or fire lines).
- (B) Manholes. Place a (M-H) mark on the pavement curb to indicate manhole locations (green paint).
- (C) Curb Stops. Place a (I) mark on the pavement curb to indicate curb stop locations (blue paint).
- (D) Cleanouts. Place a (II) mark on the pavement curb to indicate sewer clean out locations (green paint).

(23) Seal and vacuum test all manholes. All manholes which require grade adjustments are to be re-tested.

(24) Perform a television camera inspection of all sanitary sewer and storm sewers, along with the associated storm sewer laterals. Copies of the inspection tapes which are to be on a thumb drive or DVD format are to be submitted to Engineering Inspector with the City of Rockwall Engineering Department. Videos shall be taken after the franchise utilities on the project have been completed. Also forward the results of all air and mandrel test to Engineering Inspector.

(25) The lift station is to be operational and approved for use, by the design engineer and the City of Rockwall.

(26) Install guard rail at all locations as noted on the approved plans.

(27) Ryan Miller, Director of Planning and Zoning or his designated representative shall conduct an inspection of the landscaping and project screening upon completion.

(28) Information (Future Item) – Twenty-Month Maintenance Review – The City of Rockwall requires a twenty-month maintenance review of every project. This review is to be conducted at twenty-months into the two-year maintenance warranty. The Design Engineer or his designated representative along with the contractors designated representatives shall be present to perform a walkover of the project with the City of Rockwall. A second T.V. camera of sanitary sewer main shall be done at this time with a thumb drive or DVD formatted copy provided to the City of Rockwall

(29) Grass is to be established in all disturbed areas. Grass shall be at least 1” in height with 75%-80% coverage of all disturbed areas.

For additional information, regarding this check list or site work status please contact – Engineering Inspector who is the designated Construction Inspector for the site-work on this project for the City of Rockwall, regarding this list. Project acceptance is subject to but not necessarily limited to the above listed punch list items. Engineering Inspector may be reached at telephone no. 972-771-7746.

Sincerely,

Engineering Inspector  
Construction Inspector  
City of Rockwall Engineering Department





## EXAMPLE: CHECKLIST FOR FINAL ACCEPTANCE OF A COMMERCIAL PROJECT

(DATE)

(ENGINEER'S NAME)  
 (ENGINEERING COMPANY)  
 (ADDRESS)  
 (CITY, TX ZIP)

RE: (PROJECT NAME) – CHECKLIST FOR FINAL ACCEPTANCE

Dear (ENGINEER'S NAME),

The following items are to be completed at the above-mentioned site to bring the project into compliance with City specifications and to meet specific project requirements. The listed items are items identified during the walkover of the site and are to be addressed prior to final acceptance of the project. The City will conduct daily site visits (during daily rounds) at the project until completion of the noted items. A copy of this list will also be directed to the developer/owner and general contractor. The below listed items are to be directed to the appropriate responsible parties for completion.

### *REQUIRED DOCUMENTATION*

- (1) The City of Rockwall requires that the design engineer provide a letter of concurrence. The letter is to verify that the drainage flow patterns, grade to drain locations and drainage structures, including the volume of the surface and/or subsurface detention system and detention outlet structure located at the project were installed to the general elevations as shown on the approved plans. The letter shall also verify that the project was constructed to meet the approved design requirements or is within acceptable design tolerances. The Design Engineer or his designated representative shall direct all "survey-work" necessary to verify elevations and design compliance. The letter of concurrence is to have the seal and signature of the design engineer.

#### *EXAMPLE OF LETTER OF CONCURRENCE VERBIAGE WHICH WILL NOT BE ACCEPTED BY THE CITY:*

*A representative of this company visited the site and has visually verified to the best of the engineer's professional opinion, knowledge and belief, the final grading and site drainage comply with the City approved plans and details.*

#### *EXAMPLE OF LETTER OF CONCURRENCE VERBIAGE WHICH WILL BE ACCEPTED BY THE CITY:*

*A representative of this company visited the site and has visually verified to the best of the engineer's professional opinion, knowledge and belief, that based on my observations along with survey work conducted at the site, the final grading, site drainage, and detention outfall with required volume comply with the City approved plans and details.*

- (2) The Design Engineer shall furnish a digital file of the project formatted in Auto Cad 14, or 2000 format or newer and Adobe Acrobat (pdf.) format with a CD-ROM. The disk shall include a full set of plans along with any landscaping, wall plans, and details sheets.

Submit one (1) set of blue line drawings of the "Record Drawings" containing copies of all sheets. The blue line copy will be reviewed by the construction inspector **PRIOR** to producing the "Record Drawing" disk. This will allow any revisions to be addressed prior to producing the disk.

***RECORD DRAWING DISK DRAWINGS SHALL HAVE THE DESIGN ENGINEERS SEAL, SIGNATURE AND MUST BE STAMPED AND DATED AS "RECORD DRAWINGS" OR "AS BUILT DRAWINGS" ON ALL SHEETS.***

The City of Rockwall will not accept any Record Drawing disk drawings which include a disclaimer with the like or similar verbiage. A disclaimer shall not directly or indirectly state or indicate that the design engineer or the design engineers, surveyor/surveyors did not verify or grades after construction, or that the Record Drawings were based solely on information provided by the construction



contractor/contractors. Any Record Drawings which include like or similar disclaimer verbiage will not be accepted by the City of Rockwall.

#### *EXAMPLE OF ACCEPTABLE DISCLAIMER:*

*To the best of our knowledge Smith Engineering, Inc., hereby states that this plan is As-Built. This information provided is based on surveying at the site and information provided by the contractor.*

- (3) 4% Engineering Inspection Fee (Final As-Built Adjustments). Prior to the start of construction at the project, engineering inspection fees for the project were established. The preliminary inspection fee amounts were based upon the projected contract quantity and unit price amounts which were submitted to the City. A fee based on 4% of the projected quantity cost was paid to the City. The final fee amounts are to be adjusted if necessary to match the unit quantity and unit price amounts based on the as-built contract unit quantity amounts. Please provide a copy of the as-built quantity amounts with total amounts for each item. The as built amounts should be noted or stamped as "as-built contract quantity and unit price amounts". The engineering inspection fee charged by the City will be adjusted to match these amounts if necessary. The City is to receive payment on the adjusted cost amounts prior to project acceptance. As-built contract unit quantity and unit price amounts for the pavement (including fire lane if applicable), drive approaches, sidewalks, barrier free ramps, wastewater, storm sewer, drainage structures (including underground detention), water lines, along with all associated fixtures which are located within the defined rights-of-way and easements of the project.
- (4) All weekday and weekend overtime engineering inspections fees are to be paid.
- (5) Flood study review fees to be paid if there is an excess due over the initial review fee. If all of the initial fees were not utilized for the flood study review, those monies will be refunded.
- (6) Storm Sewer Outfall Coordinates. It is now necessary to tie down all the storm sewer outfall pipes to our state plane Coordinate System. The design engineer will be required to provide the following coordinate information which is to be submitted in letterform showing the x, y, and z coordinates at the end of all storm sewer outfalls of the project.
- (7) Maintenance bonds are to be submitted to the City of Rockwall for the paving and utilities installed at the project. The bonds shall be two-year 10% maintenance bonds to cover maintenance, for a two-year timeline starting from the "Date of City of Rockwall's Acceptance" for the project. There is to be no date in the starting timeline only the above wording.
  - (A) The utility bond shall cover the following utility systems and their associated fixtures.
    - Water
    - Wastewater
    - Storm sewer (including detention systems)
  - (B) The paving bond shall cover the following:
    - Street Pavement.
    - Driveway Approaches
    - Fire Lane.
    - Sidewalks.
    - Barrier free ramps.
- (8) Engineered Retaining Wall Inspection & Letter of Concurrence. The City requires the design engineer for any retaining wall which is three-feet in height or taller, to periodically inspect, or make arrangements for his designated representative to periodically inspect the retaining wall/walls during the construction process. The design engineer is to submit letter of concurrence for the retaining wall/walls to the City prior to project acceptance. The letter shall contain the seal and signature of the retaining wall design engineer.
- (9) City Council approved and owner signed final/replat plat mylars and tax certificates to be submitted to Planning Department for filing.

#### *SITE ITEMS*

- (1) Grass is to be established at all of the disturbed areas. The grass is to be maintained until such time that a general coverage density of 75-80% of the disturbed area has been established with a minimum grass stand height of one-inch.



- (2) Maintain existing or install additional construction site erosion BMP's as necessary, to stabilize the disturbed soil or contain silt migration.
- (3) All fire lanes are to be sawn and crack sealed. All miscellaneous random cracks are to be routed and sealed. All expansion joints are to be sealed in the fire lane.
- (4) The fire lane is to be re-painted where necessary if there are locations where the fire lane is scuffed or is flaking. The locations which require re-painting shall be sandblasted, prior to re-painting.
- (5) Wipe the inside ring and cover of the sanitary sewer manhole, using "Non-Shrink" grout and seal if necessary.
- (6) Repair all gouges, cracks, and other deformities on the curbs.
- (7) Adjust meter cans and valve stacks to final grade elevation.
- (8) Adjust fire hydrants to grade. All fire hydrants must have the operating nut between 19 and 28 inches above the final grade elevation around them.
- (9) All fire hydrants are to have a clearance radius of 5-feet in all directions. No structures, traffic bollards, barricades, guardrail, landscaping etc., are to be placed within the clearance area.
- (10) All valve stacks located outside of paving are to have a 2'x2' four-inch thick reinforced concrete pad around them.
- (11) Water Valve and Waste Water manhole curb cut marks. The pavement curbs are to be marked at all water valve and waste water manhole locations. The curb cut marks are to be sawn into the pavement curb. The curb cut marks are to consist of the following:
  - (A) Valves. Place a (V) mark on the curb to note the valve locations, (blue paint for general, white paint for sub outs or dead ends, and red paint for fire hydrants and or fire lines).
  - (B) Curb stops. Place a (I) mark on the pavement curb to indicate curb stop locations, (blue paint).
  - (C) Clean outs. Place a (II) mark on the pavement curb to indicate sewer clean-out locations, (green paint).
- (12) Cut an invert in the sanitary sewer connection into the existing manhole at station 0+00, and re-seal the bottom of the manhole.
- (13) Clean mud from concrete flume in detention pond.
- (14) Install floodway monument markers. The City will furnish the marker cap, which is to be set in concrete as directed by the City of Rockwall. The developers designated representative shall install the marker prior to project acceptance. Monument installation shall meet City of Rockwall specifications.
  - (A) The monument marker location is to be shown on the Record Drawing Mylar's on the grading plan.
  - (B) The City of Rockwall will furnish the marker cap.
  - (C) Install "No Dumping, Drains to Waterway" inlet markers to be installed on each inlet by the developer
- (15) All parking lot and handicap striping along with all associated signs must be installed.
- (16) All construction related trash material and miscellaneous debris is to be removed from the site and properly disposed.
- (17) Maximum slopes allowed by the City of Rockwall shall be a 4:1 slope. All slope areas which exceed the above noted slope requirements are to be re-graded or retained unless otherwise approved by the City Engineer. All slopes are to be graded so as to achieve the most gradual slope possible, unless otherwise noted on the approved construction plans.
- (18) Final Grading. Re-establish all drainage swales, as necessary to achieve conformance to the drainage patterns shown on the approved grading plans. Grade to drain any locations which may hold water or obstruct approved drainage flow patterns. All graded areas, including slopes are to be brought to a final grade surface that is smooth and uniform being relatively free of erosion washouts, tire ruts, dirt clods, silt deposits etc., care should be taken to re-grade any rough surface areas prior to the application of erosion matting or grass seeding.
- (19) All required landscaping is to be installed at the site and comply with the approved landscape plan. The site landscaping is to be inspected by Ryan Miller, Director of Planning and Zoning, or his designated representative prior to project acceptance.

For additional information, regarding this check list or site work status please contact – (Inspector's Name), who is the designated Construction Inspector for the site-work on this project for the City of Rockwall, regarding this list. Project acceptance is subject to but not necessarily limited to the above listed punch list items. (Inspector's Name) may be reached at telephone no. 972-771-7746.



Sincerely,

Construction Inspector  
City of Rockwall Engineering Department